

HINO DIESEL ENGINE WORKSHOP MANUAL

J08E-TM



(Shovel)

SMTK-E040

2005.11

GENERAL	1
STANDARD VALUE	2
PARTS TO BE PREPARED	3
ENGINE ASSEMBLY/DISASSEMBLY	4
FUEL SYSTEM	5
EMISSION CONTROL	6
ELECTRICAL	7
INTAKE	8
ENGINE MECHANICAL	9
EXHAUST	10
COOLING	11
LUBRICATION	12
STARTING AND CHARGING	13
TURBOCHARGER	14
FAILURE DIAGNOSIS FOR EACH ENGINE STATUS	15
ENGINE DIAGNOSIS CODE	16

1 GENERAL

Warning.....	1-2
How to read this manual	1-3
Precautions for work	1-7
Tightening of engine bolts and nuts	1-11
Tightening of flare nuts and hoses.....	1-13
Taper thread sealant for piping	1-14
Assembly of joints and gaskets for piping.....	1-15
Handling of liquid gasket.....	1-17
Failure diagnosis table for each problem	1-18
Failure diagnosis procedures.....	1-19
Failure diagnosis using Hino-DX.....	1-21
Connection method of Hino-DX	1-24
Chassis number and engine number	1-26

Warning

JP30002010102001

Observe the following precautions to work safely and to prevent damage to customers' vehicles.

This manual is prepared for qualified service engineers who are recognized as technical expert. Those who are not qualified, who are not appropriately trained, who performs service without appropriate tool or equipment, or who perform service with the way not specified in this manual may not only damage the vehicle, but also put service engineers and surrounding people in danger.

- Appropriate service and repair are essential to ensure safety of service engineers and safety and reliability of vehicles. Be sure to use Hino genuine parts for replacement of parts. Do not use deteriorated parts in quality.
- Items described in this manual are the procedures to be observed in service and repair. For service and repair according to this procedure, be sure to use the special tools designed for each purpose.
- If a method or a tool not recommended is used, safety of service engineers, and safety and reliability of vehicles may be impaired. Never use a method or tool not recommended.
- This manual shows "Warning" and "Caution" for items that need to be observed so that accidents may not occur during service or repair, or that damage to vehicle due to improper method may not impair safety and reliability of vehicles. These instructions cannot give warning for all possible hazards. Note that items with "Warning" or "Caution" are not absolute for safety.

How to read this manual

JP30002010102002

1. Scope of repair work

- (1) Repair work is classified into three large categories of "Diagnosis", "Mounting/removal, replacement, assembly·disassembly and inspection·adjustment" and "Final inspection".
- (2) This manual describes "Diagnosis" in the first process and "Mounting/removal, replacement, assembly·disassembly and inspection·adjustment" in the second process. Explanation of "Final inspection" in the third process is omitted here.
- (3) Although the following work is not described in this manual, it should be performed in actual work.
 - a. Jacking and lifting
 - b. Cleaning and washing of removed parts as required
 - c. Visual inspection

2. Standard value

- (1) Standard value, limit, action and tightening torque described in the text are summarized in tables.

3. Items to be prepared

- (1) Items to be prepared before work are SST, tools, gauges and lubricant, etc. These are listed in the list section of items to be prepared. Items such as general tools, jack, rigid rack, etc. that are usually equipped in general service shop are omitted.

4. How to read sections and titles

- (1) Sections are classified according to J2008, SAE standard.
- (2) For areas that show system names like "Engine control system", "Inspection", "Adjustment", "Replacement", "Overhaul", etc. of components are described.
- (3) For areas that show part names like "Injection pump", "Mounting/removal and disassembly" is described.
- (4) Illustrations of the parts catalog are shown for part layout. (Part codes in the parts catalog are described in the illustration. Major names and tightening torque are listed in the table.)

⚠ CAUTION The part layouts in this manual are inserted based on illustrations and part numbers of the parts catalog CD-ROM issued in October, 2005. (Some areas do not show exploded view. They will be additionally issued when the parts catalog CD is revised.) Be sure to use the parts catalog for confirmation of illustrations and part numbers and for ordering parts.

5. How to read troubleshooting

(1) Failure diagnosis in this manual describes Step 2 and Step 3 below :

(1) Question	"Step 1"	Hear from customers for conditions and environments of failures and check the fact.
(2) Pre-inspection (3) Reproduction method	"Step 2"	Perform diagnosis inspection, status inspection, function inspection and basic inspection. Check the failure status. If it is difficult to reproduce the problem with status inspection, use the reproduction method.
(4) Troubleshooting for each diagnosis code (5) Troubleshooting for each failure status	"Step 3"	Summarize inspection results obtained from Step 2. Perform inspection systematically according to troubleshooting procedures for each diagnosis code or failure status.
(6) Confirmation test	"Step 4"	Check if failure occurs again after repair. If it is difficult to reproduce a failure, perform the confirmation test under the conditions and environment of the failure.

(2) Pre-inspection

Pre-inspection	<ul style="list-style-type: none"> • Pre-inspection is performed in the following steps : Diagnosis inspection →Diagnosis deletion →Failure status check (Use the reproduction method if not reproduced.) →Diagnosis reconfirmation • Estimate the failure system before the reproduction test. Attach a tester and evaluate estimated failure together with failure status. Refer to the troubleshooting chart for estimated cause of a failure. • An error code is displayed if a failure occurs instantaneously. If any specific failure is not found, perform troubleshooting using the reproduction method. • Failure status check If failure is reproduced, perform Step 2 →Step 3 →Step 4. If failure is not reproduced, use the reproduction method (simulation of external conditions or check of each wire harness and connector, etc.)
----------------	---

6. How to read explanation details

(1) Part layout

Example

ENGINE MECHANICAL [J08E]

9-17

Timing Gear Cover and Flywheel Housing

Part layout

☆ JP04117090402003

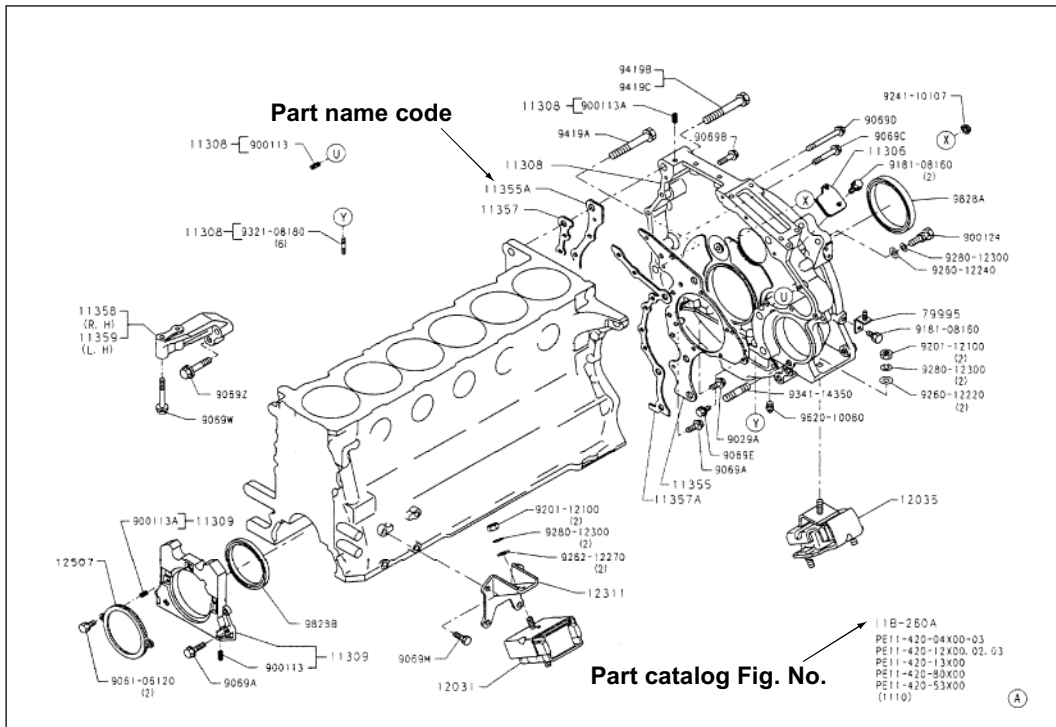

☆ SAPH041170900182

11308	Flywheel housing	11390	End plate	Description of part name code
11309	Oil seal retainer	9828A	Front oil seal*	
11357	Gasket*	9828B	Rear oil seal*	
11357A	Gasket*			

*Parts not to be reused.

Left: Part name code (nut)

Tightening torque

9069H	M14 : 171.5N m{1, 750kgf cm}	9419A	M16 : 196N m{2, 000kgf cm}
9069J	M12 : 97N m{990kgf cm}	9419B	M16 : 196N m{2, 000kgf cm}

SAPH300020100001

☆ It is the ID number for parts to prepare electronic data. It is not required for repair work.

7. Definition of terms

Terms in this manual are defined as follows :

- (1) Direction
 - a. Individual unit
 - Front/back direction
The power input side is front and the output side is back.
 - Rotating direction
When viewed from the rear, the clockwise direction is right rotation and the counterclockwise direction is left rotation.
 - Vertical direction
With a unit mounted on the machine main unit, the upward direction is upper and the downward direction is lower.
 - Left/right direction
When viewed from the rear, the left direction is left and the right direction is right.
- (2) Standard value Basic dimension excluding tolerance and clearance generated by tolerances when two parts are joined
- (3) Repair limit It is the value requiring repair. Symbol of + or - with the value means increase or decrease to the standard value.
- (4) Operation limit It is the value requiring replacement. Symbol of + or - with the value means increase or decrease to the standard value.
- (5) Warning It is an item that may result in risk of human life or serious injury by incorrect handling.
- (6) Caution It is an item that should not be performed including inhibited work or an item that require attention in working procedures.
- (7) Reference It is supplementary explanation in work.

8. Unit

- (1) SI unit is used in this manual. SI unit is the international unit to unify the conventional different international units into one unit per quantity and to promote smooth technical communications.
- (2) This manual shows both the SI unit and conventional units. The conventional units are shown in { }.

	SI unit	Conventional unit	Conversion value ^{*1} (1[Conventional unit] = X [SI unit])		SI unit	Conventional unit	Conversion value ^{*1} (1[Conventional unit] = X [SI unit])
Force	N	kgf	1kgf=9.80665N	Spring constant	N/mm	kgf/mm	1kgf/mm=980665N/mm
Torque ^{*2}	N·m	kgf·cm	1kgf·cm=0.0980665N·m	Volume	L	cc	1cc=1mL
Pressure	Pa	kgf/cm ²	1kgf/cm ² =98.0665kPa =0.0980665MPa	Efficiency	W	PS	1PS=0.735499kW
		mmHg	1mmHg=0.133322kPa	Calorific value	W·h	cal	1kcal=1.13279W·h
Rotational speed	r/min	rpm	1rpm=1r/min	Fuel consumption rate	g/W·h	g/PS·h	1g/PS·h=1.3596g/kW·h
	min ⁻¹		1rpm=1min ⁻¹				

^{*1}: X means the value when 1 [Conventional unit] is converted to the SI unit.

It is used as the conversion factor from the conventional unit to the SI unit.

^{*2}: The conversion value of the torque may vary depending on the unit.

Observe the standard values described for each unit.

Precautions for work

JP30002010101001

1. General precautions

To ensure safety in work and to prevent accidents, observe the following items :

- (1) Appearance
 - a. Wear safety goggles.
 - b. Do not wear watch, necktie, ring, bracelet, necklace, etc. to prevent accident before work.
 - c. Bind long hair at the back.
 - d. Be sure to wear a cap and safety shoes.
- (2) Safety work
 - a. Do not touch radiator, muffler, exhaust pipe, tail pipe, etc. after stop of the engine to prevent burn.
 - b. Do not put your clothes or tools near the rotating part (in particular, cooling fan or V-belt) during operation of the engine.
 - c. Remove the starter key when the engine is not started.
 - d. Start the engine at a well ventilated place so that carbon monoxide may not be filled.
 - e. Since gas from the fuel or the battery is flammable, do not spark a fire or smoke a cigarette near the area.
 - f. Since the battery fluid is poisonous and corrosive, be careful for handling.
 - g. Do not short-circuit the cable of the battery or starter. Otherwise, the cable may be burned or burn may occur.
 - h. If a tool or rag is left in the engine compartment, it may be bounced with a rotating part of the engine, resulting in injury.
 - i. To tow a failure machine, refer to "Towing" in the "Operation manual" of the machine.

2. Precautions for service work

Pay attention to the following points before service work

- (1) Preparation before disassembly
 - a. Prepare general tools, special tools and gauges before work.
 - b. To disassemble a complicated area, put a stamp or match mark on the location not functionally affected to ease assembly. To repair the electric system, disconnect the cable from the minus terminal of the battery before work.
 - c. Perform inspection according to the procedure in the text before disassembly.
- (2) Inspection during disassembly

Every time parts are removed, check the area where the parts are assembled and check for deformation, damage, wear or scratch.
- (3) Arrangement of disassembled parts

Place removed parts neatly in order. Separate parts to be replaced from parts to be reused.
- (4) Washing of disassembled parts

Clean and wash parts to be reused well.
- (5) Inspection and measurement

Inspect and measure parts to be reused as required.
- (6) Assembly
 - a. Keep the specified standard values (tightening torque, adjusting values, etc.) and assemble correct parts in the correct order.
 - b. Be sure to use genuine parts for parts to be replaced.
 - c. Use new packing, gasket, O-ring and cotter pin.
 - d. Use seal gaskets for some areas where gaskets are used. Apply specified oil or grease to sliding areas where application of oil is required, and apply specified grease to the oil seal lip before assembly.
- (7) Check of adjustment

Make adjustments to the service standard values using a gauge or tester.

3. Precautions for electric system

(1) Removal of battery cable

- a. In an electric system, remove the cable from the battery minus (-) terminal to prevent burnout due to short-circuit.
- b. When the battery cable is removed, the battery terminal may be damaged. Loosen the nut completely and never pry it for removal.

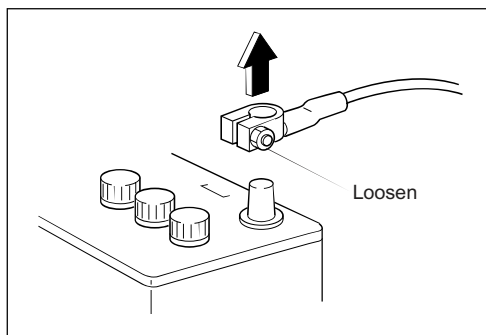

(2) Handling of electronic parts

- a. Do not give impact on electronic parts such as computer and relay.
- b. Do not place electronic parts at a high temperature and humidity area.
- c. Do not expose electronic parts to water in washing of a vehicle.

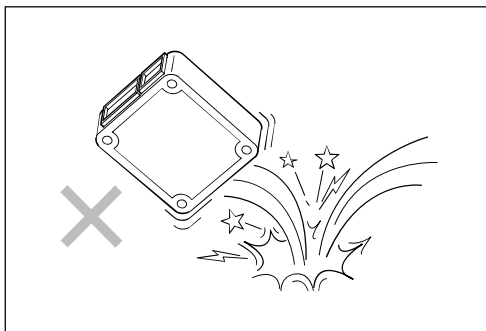

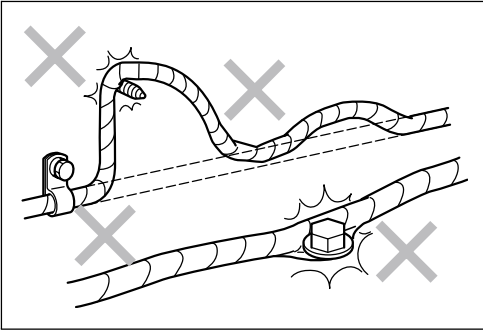

SAPH300020100004

(3) Handling of wire harness

- a. Mark clamps and clips to prevent interference of a wire harness with body edge, sharp edge and bolts. Be sure to reassemble it to the original position.
- b. When parts are assembled, be careful not to pinch a wire harness.

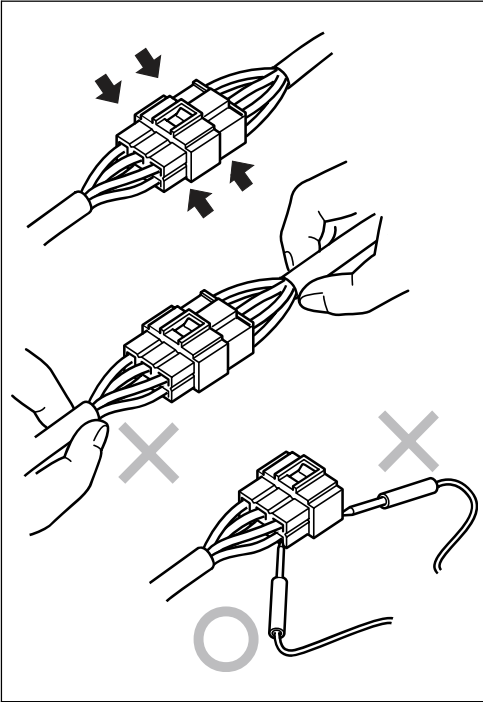

SAPH300020100005

(4) Handling of connector

- a. When a connector is removed, hold the connector (as shown by the arrow in the left) and pull it out. Do not pull the wire harness.
- b. Unlock the locking connector before pulling.
- c. Insert the locking connector completely until it clicks.
- d. To insert a test lead into the connector, insert it from the back of the connector.
- e. If it is difficult to insert a test lead from the back of the connector, prepare a harness for inspection.

4. Precautions for electric welding

Inadvertent electric welding on a cab or frame may cause reverse welding current from the grounding circuit, resulting in damage to electric and electronic parts. Observe the following items for electric welding.

- (1) Turn "OFF" the starter switch.
- (2) Make sure that switches are "OFF".
- (3) Disconnect the minus (-) terminal of the battery according to the removal procedure of the battery cable.
- (4) Disconnect connectors of each computer.
- (5) Remove all fuses. (For locations of fuses, refer to "Electrical Chapter".)
- (6) Be sure to connect grounding of the electric welding machine near the welding area.
Connect grounding from a bolt (plated bolt) or a frame near the welding area.
Remove paint of the frame for connection of grounding from the frame.
The seal and the bearing etc. that please make sure do not enter between the weld and the ground section.
- (7) Other precautions
 - a. Put a cover on rubber hoses, wire harnesses, pipes, tires, etc. around the welding area so that they may not be exposed to spatter.
 - b. Perform welding under appropriate conditions and minimize heat effect in the peripheral area. Also maintain welding quality.
- (8) After welding, connect and assemble in the order of the fuse and the minus terminal of the battery disassembled. When paint is removed from a frame or cab, apply rust preventive coating with the same color.
- (9) After reassembly, check the function if it operates correctly.

Tightening of engine bolts and nuts

JP30002010102003

1. Tightening torque of general standard bolts

(1) For bolts with seatings

Unit : N·m{kgf·cm}

Screw diameter x Pitch	7T	9T
M8 x 1.25 (Coarse thread)	28.5{290}	36{370}
M10 x 1.25 (Fine thread)	60{610}	74.5{760}
M10 x 1.5 (Coarse thread)	55{560}	68.5{700}
M12 x 1.25 (Fine thread)	108{1, 100}	136{1, 390}
M12 x 1.75 (Coarse thread)	97{990}	125{1, 280}
M14 x 1.5 (Fine thread)	171.5{1, 750}	216{2, 210}
M14 x 2 (Coarse thread)	154{1, 570}	199{2, 030}
Remark	Bolt with number "7" on the head	Bolt with number "9" on the head

⚠ CAUTION • 8T bolt is in accordance with 7T bolt.

(2) For bolts with washers

Unit : N·m{kgf·cm}

Screw diameter x Pitch	4T	7T	9T
M6 x 1 (Coarse thread)	6{60}	10{100}	13{130}
M8 x 1.25 (Coarse thread)	14{140}	25{250}	31{320}
M10 x 1.25 (Fine thread)	29{300}	51{520}	64{650}
M10 x 1.5 (Coarse thread)	26{270}	47{480}	59{600}
M12 x 1.25 (Fine thread)	54{550}	93{950}	118{1, 200}
M12 x 1.75 (Coarse thread)	49{500}	83{850}	108{1, 100}
M14 x 1.5 (Fine thread)	83{850}	147{1, 500}	186{1, 900}
M14 x 2 (Coarse thread)	74{750}	132{1, 350}	172{1, 750}
Remark	Bolt with number "4" on the head Projection bolt Stud with R surface at free end	Bolt with number "7" on the head Stud with C surface at free end	Bolt with number "9" on the head

⚠ CAUTION • 8T bolt is in accordance with 7T bolt.

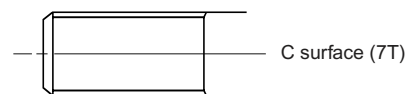
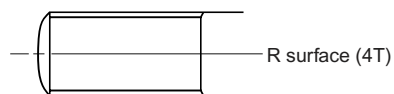

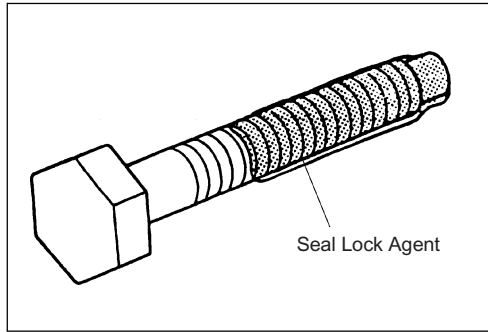

SAPH300020100007

2. Precoated bolt

Precoated bolt is the bolt with application of seal lock agent at the thread.

- (1) When re-application of lock agent is required
 - a. When precoated bolts are removed
 - b. When precoated bolts are moved due to tightening check (for loosening or tightening)

NOTICE • **Check torque with the lower limit of the tightening torque allowable value. If movement is found, tighten the bolt according to the procedure below.**

- (2) Re-use method of precoated bolt lock
 - a. Clean bolt and screw holes. (Clean screw holes for replacement.)
 - b. Dry completely by blowing air.
 - c. Apply the specified seal lock agent to the thread of the bolt.

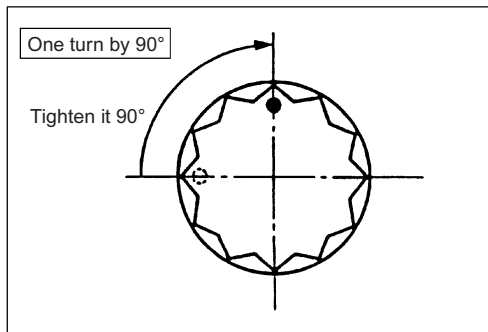

SAPH300020100008

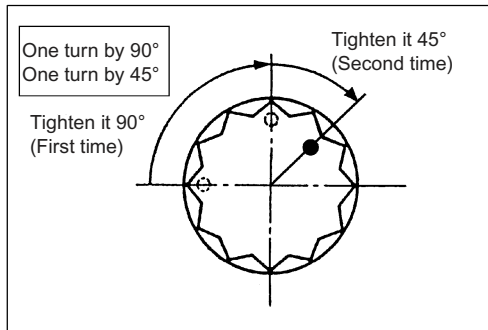

SAPH300020100009

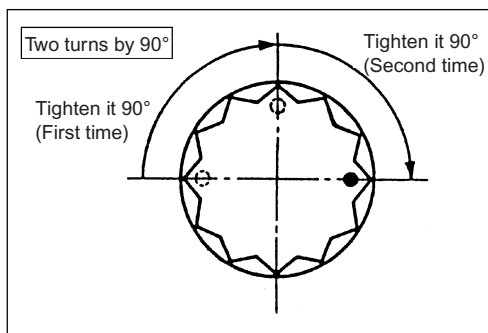

SAPH300020100010

3. Plastic region tightening method (angle method)

- (1) Precautions

Some engines are tightened with the plastic region tightening method.

Since it is different from the conventional method, tighten it according to the instruction in the text.

- (2) Parts tightened

Cylinder head bolt, crankshaft main bearing cap bolt, connecting rod bearing cap bolt, etc.

⚠ CAUTION • **Measure the overall length of the bolt before assembly and replace the bolt if the length exceeds the operation limit.**
Apply engine oil to bolt seating and bolt thread in assembly.

- (3) Tightening method after tightening to seating torque

Tightening of 90° , 135° (90° once and 45° once) and 180° (90° twice) is available.

Tightening of flare nuts and hoses

JP30002010102005

1. Tightening torque of pipe flare nut

Unit : N·m{kgf·cm}

Pipe outer diameter	φ4.76	φ6.35	φ8	φ10	φ12	φ15
Material						
Steel pipe	15±5{150±50}	25±5{250±50}	36±5{370±50}	52±7{530±70}	67±7{680±70}	88±8{900±80}

2. Tightening torque of hoses

Unit : N·m{kgf·cm}

	Hose outer diameter φ10.5 fitting	Hose outer diameter φ13, φ20, φ22, fitting at packing	Hose outer diameter PF3/8 fitting
Air hose	21.5±1.5{215±15}	41.5±2.5{425±25}	—
	Only meter gauge 10{100}		
Brake hose	Packing 51.5±7.5{525±75}	—	—

3. Lock nut tightening torque of brass joint

Unit : N·m{kgf·cm}

Screw nominal size	M12	M16	M20	M27
Tightening torque	15±2{150±20}	66±6{670±60}	97±9{990±90}	209±19{2130±190}

Taper thread sealant for piping

JP30002010102006

The taper thread of the air pipe joint has application of sealant [Loctite # 575 (by Japan Loctite)]. Follow the procedures below for connection or disconnection of pipes.

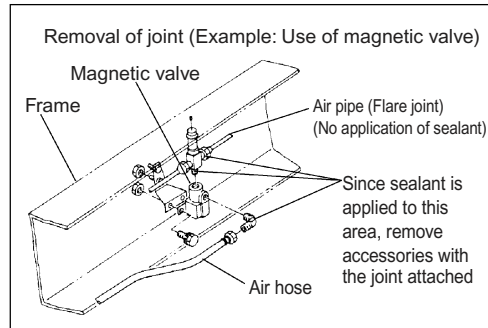

SAPH300020100016

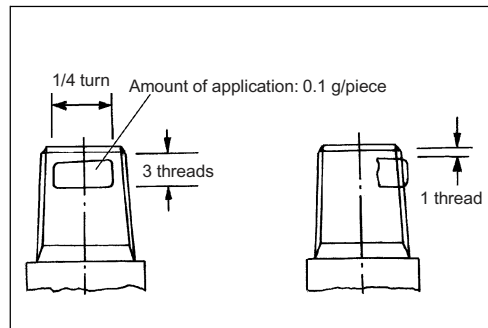

SAPH300020100017

1. For disconnection

- (1) The sealant (# Loctite 575) has strong sealing feature. The return torque of the taper joint is increased about 1.5 times the initial tightening torque. When the joint is disconnected, use a long wrench for disconnection
- (2) When a joint at a poorly accessible area is replaced, remove accessories first and disconnect the joint.

2. For connection

- (1) For application of sealant (# Loctite 575), wipe the sealing area completely with a rag or thinner. Apply sealant directly to about three ridges for quarter round with offset of one ridge from the end. Tighten it according to the tightening torque in the table below. Remove dirt completely from the mating part (female) before tightening.

CAUTION • If your eye or skin comes in contact with sealant, wash it off immediately with water.

Tightening torque of taper joint

Unit : N·m{kgf·cm}

Screw diameter	1/4	3/8	1/2
Material			
Steel	49±10{500±100}	64±15{650±150}	
Aluminum, brass	25±5{250±50}	34±5{350±50}	44±5{450±50}

- (2) When a sealing tape is replaced with sealant, remove the tape completely first as in (1).

CAUTION • Be careful to prevent entry of dirt or foreign matter in the pipe.

- (3) If air leak is found after assembly with application of sealant, air leak cannot be stopped with additional tightening. Assemble the part again according to (1) and (2).

Assembly of joints and gaskets for piping

JP30002010102007

1. Tightening torque of joints

Unit : N · m{kgf · cm}

Sealing method Tightening screw size	Gasket sealing method (Aluminum + Rubber or Copper)	Metal sealing method (Flare pipe type, nipple connector type)	
		Type A	Type B
M8	13{130}		
M10	20{200}		11{110}
M12	25{250}	20{200}	
M14	25{250}	31{320}	
M16	29{300}	39{400}	
M18	39{400}	59{600}	
M20	*39{400}	64{650}	20{200}
M24	69{700}		
M28	*127{1300}		

2. Joint assembly procedure and subsequent inspection

- (1) Before assembly, make sure that there is no dirt or burr on the seating surface (mating part, pipe joint, gasket, etc.).
- (2) Since pipes have some degrees of freedom for assembly, the seating surface tends to incline. Tighten pipes finally after temporary tightening to prevent leak.
- (3) After tightening, apply the specified pressure to each pipe joint to ensure that there is no leak.
- (4) Observe the values above for each tightening torque.

*When assembled soft washer # 4840FR-N (aluminum and rubber carbon pressure bonding) is loosened or removed, be sure to replace it with a new part. This is not necessary for normal retightening.

3. Examples of joint methods in various pipes

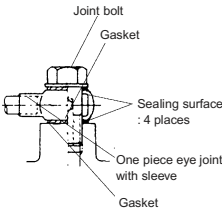
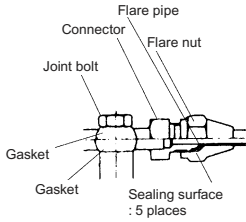
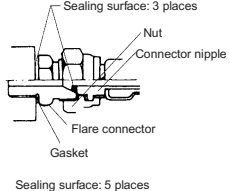
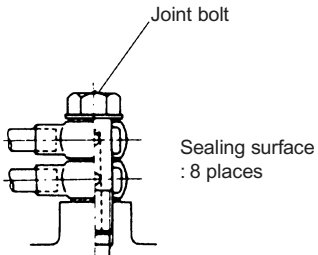
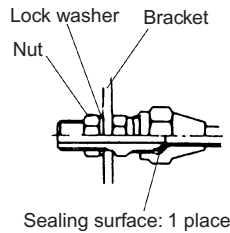
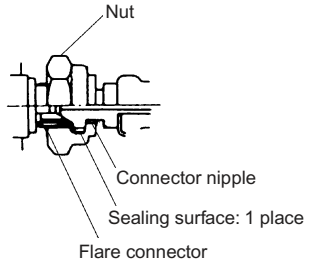
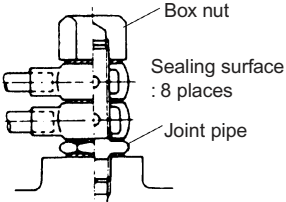
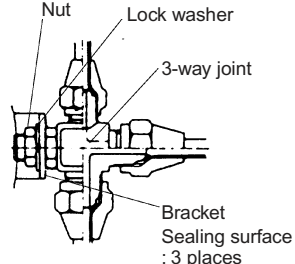
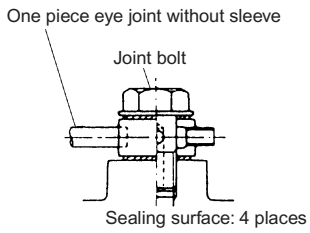
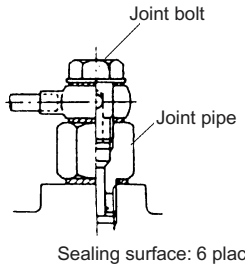
Gasket sealing method	Metal sealing method	
	Type A (Flare pipe type)	Type B (Nipple connector type)
		
		
		
		
		

Handling of liquid gasket

JP30002010102008

1. Application of liquid gasket and part assembly procedure

- (1) Remove old liquid gasket on each part and mating part completely. Clean the parts with a rag to prevent deposit of oil, moisture, dirt, etc.
Be sure to overlap parts at the beginning and at the end of application.
- (2) Be careful for offset with the mating part when a part applied with liquid gasket is assembled. Apply the liquid gasket again if offset occurs.
- (3) Assemble parts within 20 minutes after application of the liquid gasket.
If 20 minutes has passed, remove the liquid gasket and apply it again.
- (4) Start the engine at least 15 minutes or more after assembly of parts.

2. Removal of parts

- (1) When parts are removed, do not pry one place only. Remove parts by prying each other using collar or clearance on the flange. When gasket is removed, be careful to prevent entry of gasket offal into the engine.

3. Others

- (1) When the liquid gasket is contained in a tube, use the accompanying winding tool. When it is contained in a cartridge, use the application gun.

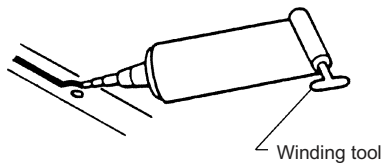

Tube: 150 g

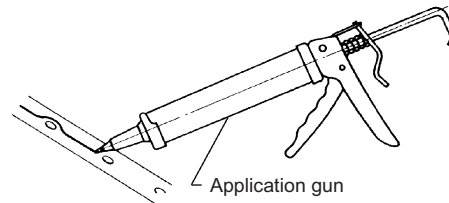

Cartridge type: 300 g

For a tube, desired application width may be obtained from the cut position at the nozzle end.

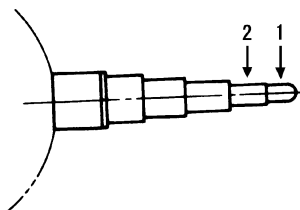

Nozzle of tube

1 : Approx. 2 mm at the 1st section cut

2 : Approx. 5 mm at the 2nd section cut

Failure diagnosis table for each problem

JP30002010301001

Engine mechanical		Causes and actions are described for each item.	
Status	Cause	Action	
Engine overheat (coolant)	Insufficient coolant	Replenish coolant	
	Faulty thermostat	Replace thermostat	
	Water leak from cooling system	Correction	
	Faulty coolant pump	Repair or replace	
	Faulty head gasket	Replace head gasket	
Engine overheat (radiator)	Clogging of radiator	Cleaning of radiator	
	Corrosion of cooling system	Clean and repair cooling system	
	Clogging of radiator core front part	Clean radiator	
	Faulty radiator cap	Replace radiator cap	
Engine overheat (compression pressure)	Non-synchronous injection timing	Adjust injection timing.	
	Faulty fuel injection pressure	Adjust injection pressure	
	Faulty fuel	Replace with correct fuel	
	Faulty injector	Replace injector	
Engine overheat (lubrication unit)	Deterioration of engine oil	Replace engine oil	
	Faulty oil pump	Replace oil pump	
	Insufficient engine oil	Replenish engine oil	
Large engine oil consumption (piston, cylinder liner and piston ring)	Wear of piston ring and cylinder liner	Replace piston ring and cylinder liner	
	Damage to piston ring	Replace piston ring and cylinder liner	
	Faulty fixing of piston ring	Replace piston ring and cylinder liner	
	Faulty assembly of piston ring	Replace piston ring and cylinder liner	
	Faulty engine oil	Replace engine oil	
	Faulty piston ring joint	Reassemble piston ring	
Large engine oil consumption (valve and valve guide)	Wear of valve stem	Replace valve and valve guide	
	Wear of valve guide	Replace valve guide	
	Faulty assembly of valve stem seal	Replace stem seal	
	Excessive oil lubrication to rocker arm	Inspection of clearance between rocker arm and rocker arm shaft	
Large engine oil consumption (others)	Faulty oil level gauge	Replace with correct level gauge	
	Excessive filling of engine oil	Fill with appropriate amount of oil.	
	Leak of engine oil	Repair or replace the part of oil leak.	
Piston seizure (in operation)	Sudden stop of engine	Perform warm-up before stop of engine	
Piston seizure (lubrication unit)	Insufficient engine oil	Replenish engine oil	
	Deterioration of engine oil	Replace engine oil	
	Incorrect engine oil	Replace with correct engine oil.	
	Low oil pressure	Inspection of lubrication unit	
	Faulty oil pump	Replace oil pump	
Piston seizure	Abnormal combustion	Refer to overheat section.	
Piston seizure	Cooling unit	Refer to overheat section.	

SAPH300020100031

Failure diagnosis procedures

JP30002010301002

1. Display of failure code

- (1) If the system has an error, the failure code is displayed on the multiple display of gauge cluster .

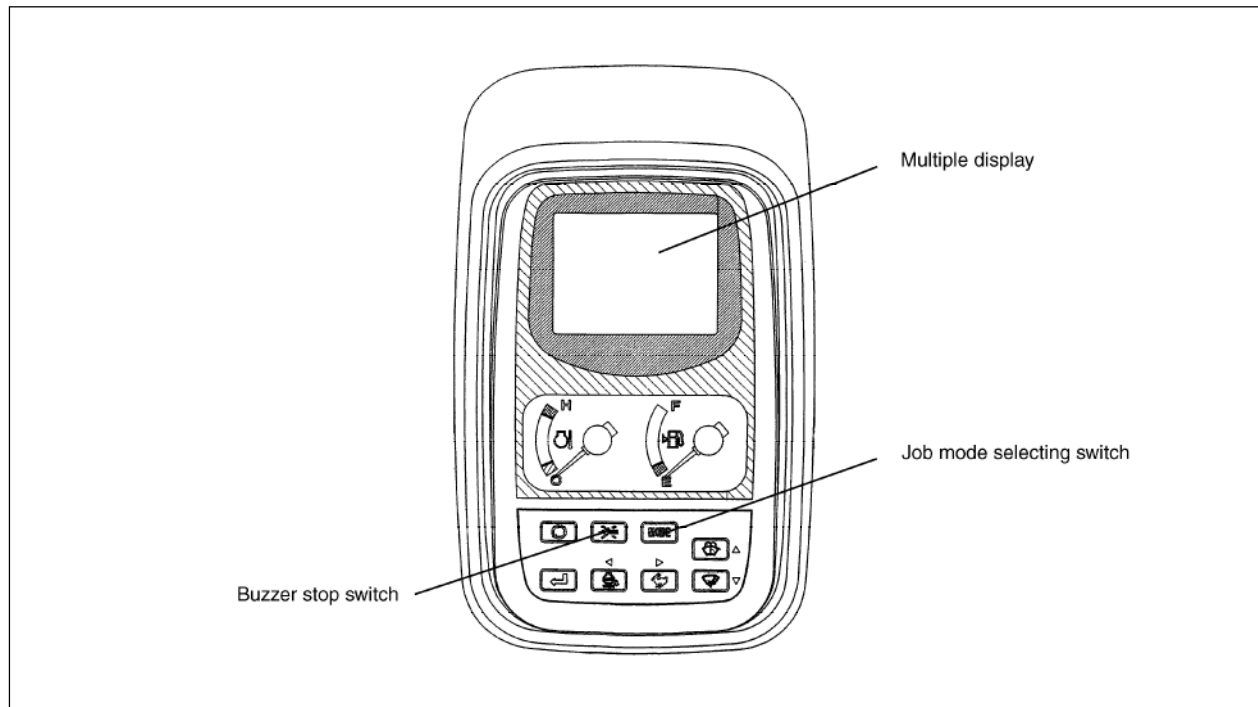

SAPH300020100032

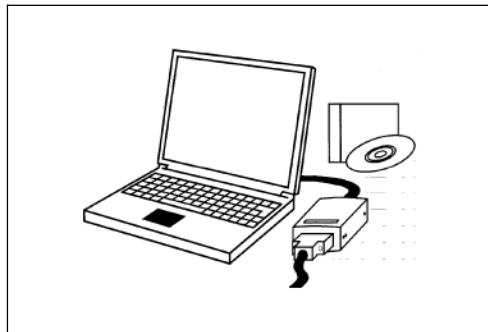

SAPH300020100033

2. Deletion method of past failure

- (1) To delete past failures of the engine ECU, use HINO-DX on the PC. (Refer to "Hino field support system operation manual".)

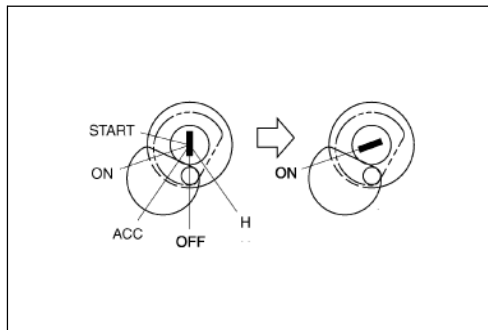

SAPH300020100034

3. Deletion of cluster gauge past failure

- (1) Turn "ON" the starter switch.
- (2) When the buzzer stop switch is pressed consecutively 5 times in 10 seconds, the failure history mode is displayed.
- (3) Press work mode selecting switch and the buzzer stop switch at the same time for 10 seconds or more.
- (4) When the display shows "No error", deletion is completed.
- (5) Turn "OFF" the starter switch.

4. How to read troubleshooting for each diagnosis monitor code

- (1) "Diagnosis code table" and "Troubleshooting for each code" are described for each system that gives output of the diagnosis monitor code. When the diagnosis monitor code is known, troubleshooting can be started from the code list.

ENGINE DIAGNOSIS CODE [Engine Common] 3-15

Failure of main speed sensor (DTC code P0335/diagnosis monitor code 13)

JP03Z01030601004

1 | Measurement of resistance between terminals

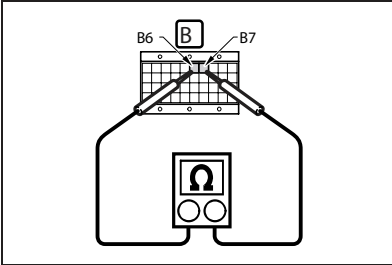

SAPH03Z010300010

1. Set the starter key to "LOCK" and connect the signal check harness.
2. Remove the ECU side connector of the signal check harness and measure the resistance between terminal B6 and terminal B7.

Details of work

Standard value : Approx. 125.5 17 (20 dC)

NG

[3] Go to measurement of resistance between sensor terminals.

OK

2 | Check of diagnosis code

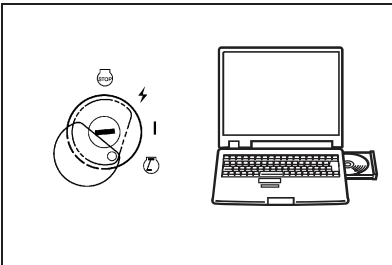

SAPH03Z010300011

1. Connect the ECU side connector of the signal check harness. After deleting the past failure, output the diagnosis code again.

Standard : Normal

NG

Contact failure of ECU connector, ECU failure, short-circuit of harness

OK

Normal

3 | Measurement of resistance between terminals

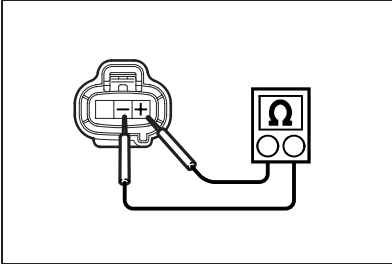

SAPH03Z010300012

1. Remove the connector of the main engine speed sensor and measure the resistance between No. 1 and No. 2 terminals at the sensor.

Standard value : Approx. 125.5 17 (20 dC)

NG

Failure of main engine speed sensor

Indicates replacement of the main engine revolution sensor.

OK

Check the harness of the relevant circuit and repair the faulty area.

Harness disconnection or connector failure

Failure diagnosis using Hino-DX

JP30002010301003

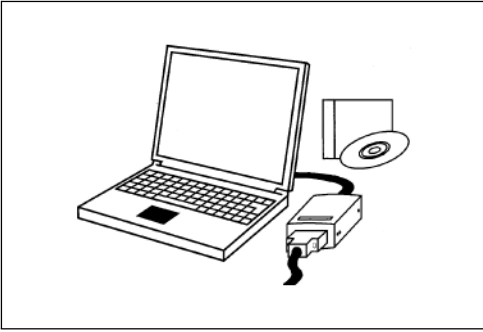

SAPH300020100036

⚠ CAUTION Hino-DX is used for inspection and adjustment of the system in addition to failure diagnosis.

1. Hino-DX

- (1) With Hino-DX, failure of the common rail fuel injection system can be diagnosed. The interface box (Hino-Bowie) and the special cable are required for connection to the vehicle.

Special tool : 380100046 Hino-Bowie

380100047 Cable between vehicle and Hino-Bowie

Field support system (CD-ROM for software) Hino Diagnostic eXplorer (Hino DX) 380100045

- ⚠ CAUTION**
- Install the software of the Hino Diagnostic eXplorer (Hino DX) in the PC. For the installation method, refer to the instruction manual accompanying the CD.

2. List of failure diagnosis tools

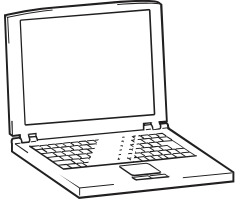
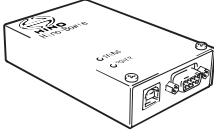
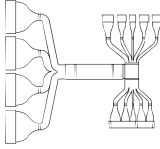
Part name	Part No.	External shape	General description and function
PC (DOS/V standard)	—		<ul style="list-style-type: none"> Operating system(OS) : Windows95, Windows98(IE5.0 or later), Windows2000(SP3, IE5.0 or later), WindowsXP(SP1a, IE6.0 or later) CPU and memory : Conditions that assure operation of the above operating system Display : 800 x 600, 256 colors or more
Hino-Bowie (Interface box)	09121 - 1040 Cable between vehicle and Hino-Bowie (09042 - 1190)		<ul style="list-style-type: none"> PC interface
Signal check harness	09049 - 1080 (for common rail fuel injection system)		Interrupting installation between vehicle harness and ECU allows inspection with a tester rod while the power is supplied.

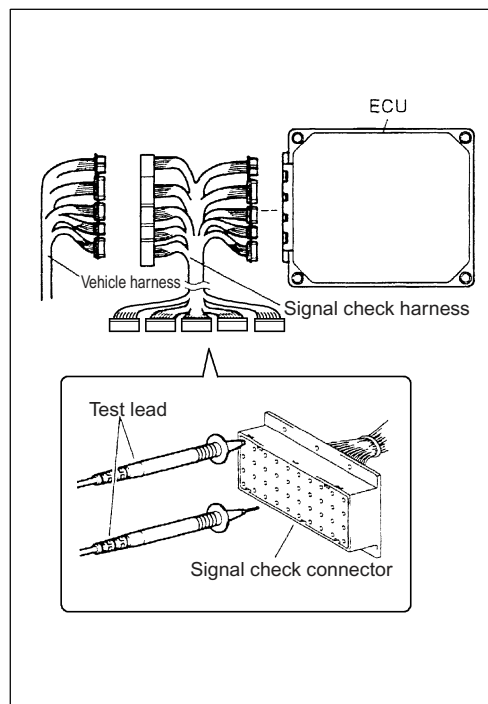

SAPH300020100040

3. Connection of signal check harness

- (1) To prevent damage to the ECU connector and to improve accessibility, connect the signal check harness and put a testing rod on the signal check connector of the signal check harness for measurement.

- a. Disconnect the connector from the ECU.

⚠ CAUTION • Do not break the locking tab of the connector.

- b. Connect the signal check harness to the machine harness and the ECU.
Signal check harness
(for common rail fuel injection system)

Part No.
380100048

(2) Terminal No.

For the signal check harness connector, the ECU terminal number in the text is treated as follows :

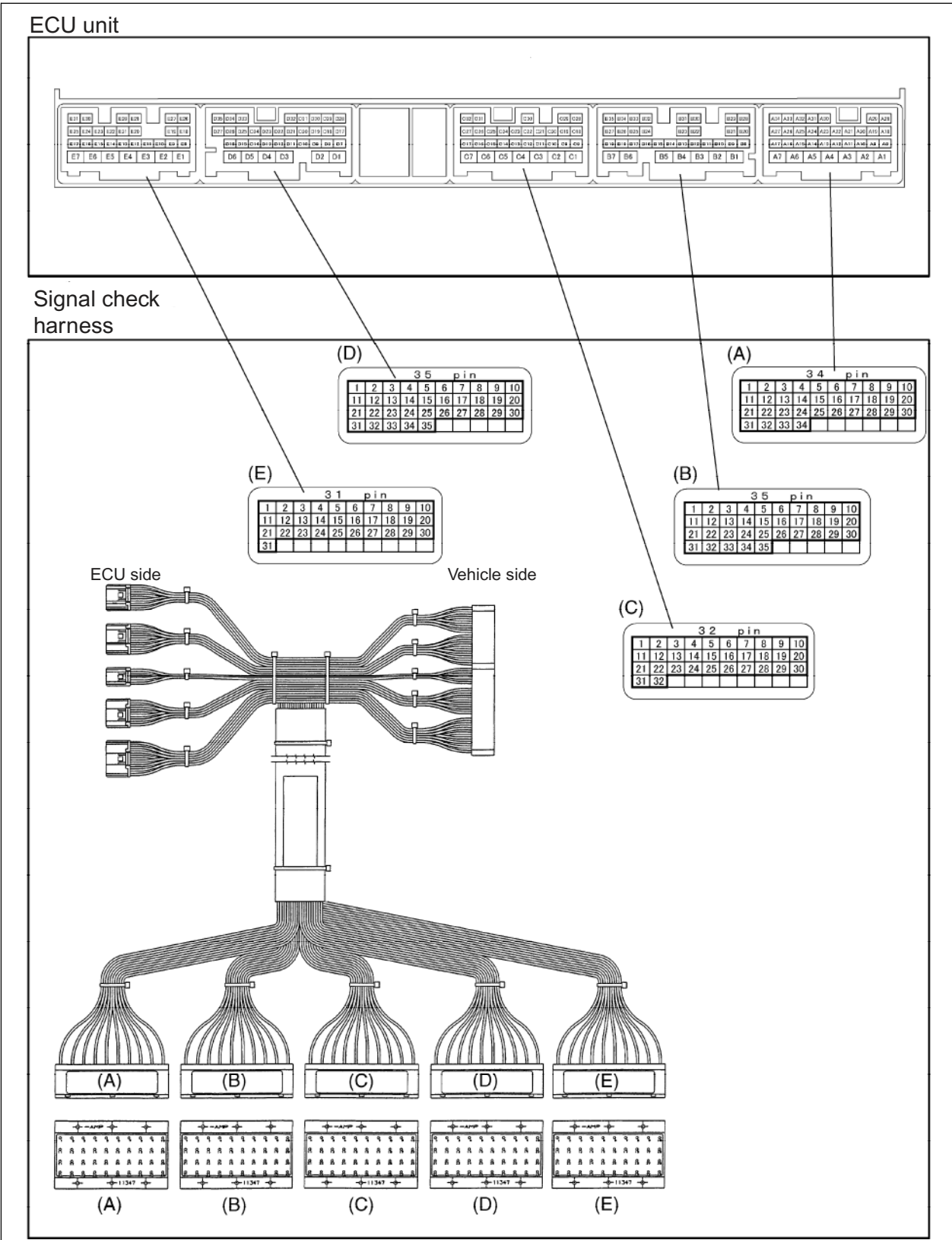

Connection method of Hino-DX

JP30002010301004

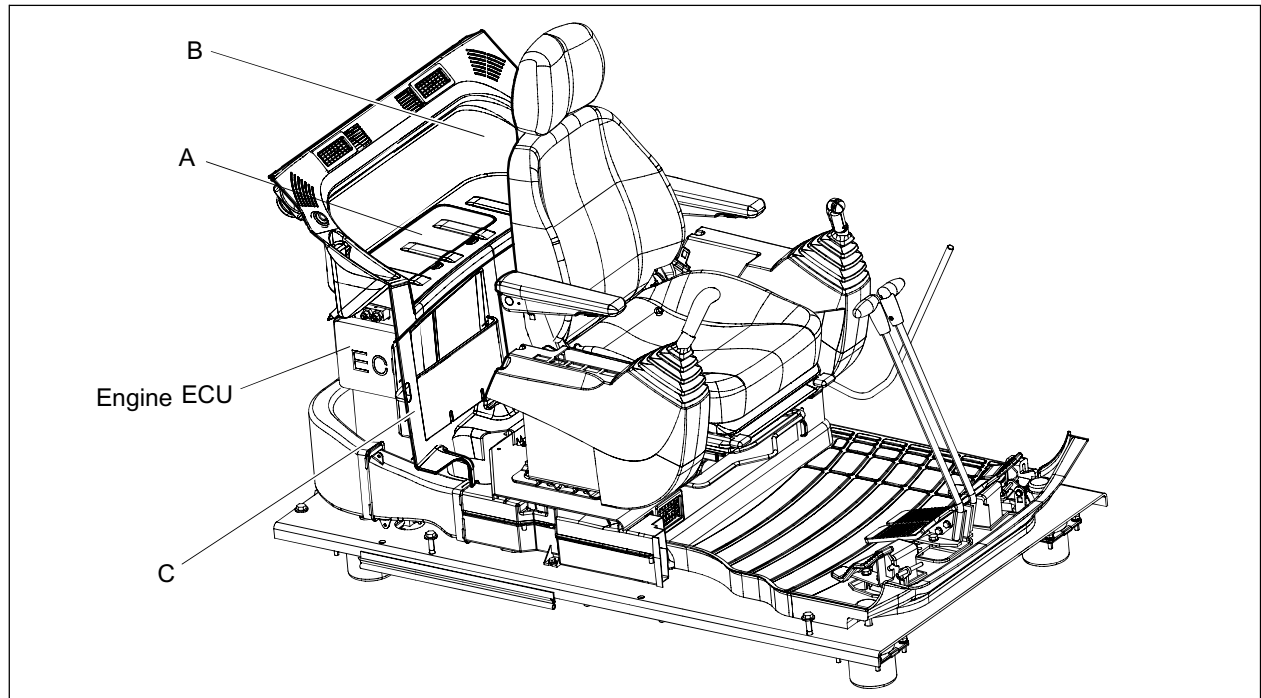

SAPH300020100043

1. Removal of cover at the rear of the driver's seat

- (1) Remove maintenance cover A. (Two tabs)
- (2) Remove the rear cover B mounting bolts M6 (4 places) which are found after removing maintenance cover A and remove the clips at the back of rear cover B.
- (3) Remove rear cover B.
- (4) Remove bolts M6 (2 places) at the lower part of rear cover C and clips (2 places) and remove cover C.

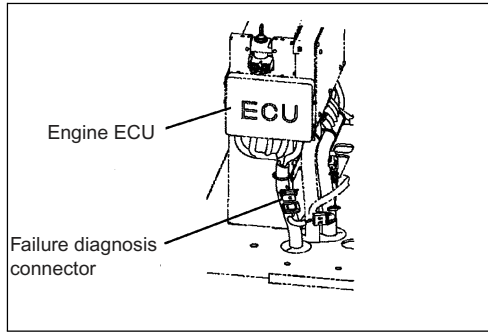

2. Connection of Hino-DX

- (1) Connect the failure diagnosis connector to the PC which installed Hino-DX through the interface box.

Special tool : 380100046 Hino-Bowie (Interface box)
380100047 Connecting cable
CD-ROM Hino-DX 380100045

- (2) Set the starter key to "ON" and start Hino-DX.

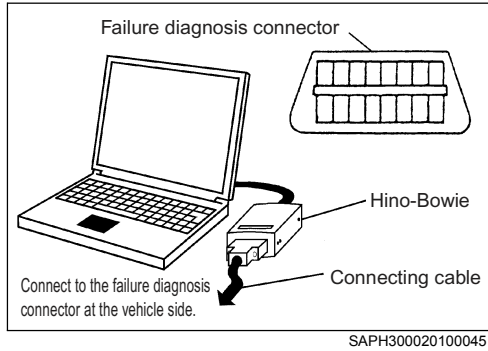

Chassis number and engine number

JP30002010401001

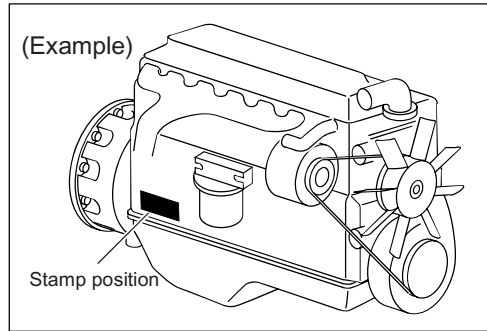

1. Engine type and engine number

- (1) Engine type and engine number are stamped at the left cylinder block when viewed from the cooling fan. For order of parts, information of this number will facilitate procedures smoothly.

Ex. J08E TA10003

2 STANDARD VALUE

2

Engine Body	2-2
Standard value.....	2-2
Tightening torque.....	2-2
Fuel System	2-2
Tightening torque.....	2-2
Emission Control	2-3
Tightening torque.....	2-3
Intake	2-3
Tightening torque.....	2-3
Engine Mechanical	2-3
Standard value.....	2-3
Tightening torque.....	2-11
Exhaust	2-12
Tightening torque.....	2-12
Cooling	2-12
Standard value.....	2-12
Lubrication	2-12
Standard value.....	2-12
Tightening torque.....	2-13
Starting and Charging	2-14
Standard value (alternator 60A)	2-14
Tightening torque (alternator 60A).....	2-14
Standard value (starter)	2-15
Tightening torque (starter)	2-16
Turbocharger	2-16
Standard value.....	2-16
Tightening torque.....	2-16

Engine Body

Standard value

JP30002020205001

Unit : MPa {kgf/cm², lbf/in.²}

Inspection item	Standard value	Repair limit	Service limit	Action
Compression pressure (Engine revolution per cylinder: 150 r/min)	2.9 - 3.1 {30 - 32, 421 - 450}	—	2.3{24, 334}	Overhaul
			Difference between cylinders 0.3{3, 44} or less	

Tightening torque

JP30002020205002

Unit: N · m {kgf · cm, lbf · ft}

Tightening area	Tightening torque	Remark
Engine mounting nut	74{750, 55}	
Starter B terminal	7.8 - 8.8{80 - 110, 5.8 - 6.5}	
Alternator B terminal	3.3 - 4.4{33 - 45, 2.4 - 3.2}	
Oil pan drain cock	41{420, 30}	
Radiator hose band	4.5 - 5.0{45 - 50, 3.3 - 3.7}	
Fuel filter air bleeding plug	4.9 - 8.9{50 - 90, 3.6 - 6.6}	

Fuel System

Tightening torque

JP30002020205003

Unit : N · m {kgf · cm, lbf · ft}

Tightening area	Tightening torque	Remark
Injector clamp	25{250, 18}	
Supply pump - Bearing holder case	28.5{290, 21}	
Bearing holder case - Pump drive	28.5{290, 21}	
Supply pump coupling flange mounting nut	63.7{650, 47}	
Injector harness	2.2{22, 1.6}	
Fuel filter air bleeding bolt	1.7 - 2.6{17.3 - 23, 1.2 - 1.9}	

Emission Control

Tightening torque

JP30002020205004

Unit : N·m {kgf·cm, lbf·ft}

Tightening area	Tightening torque	Remark
EGR pipe	57±11 {582±116, 42±8}	
EGR valve mounting bolt	68.5 {700, 51}	
EGR cooler mounting bolt	37 {377, 27}	
EGR cooler - Exhaust manifold	68.5 {700, 51}	

Intake

Tightening torque

JP30002020205005

Unit : N·m {kgf·cm, lbf·ft}

Tightening area	Tightening torque	Remark
Intake manifold mounting bolt	28.5 {290, 21}	

Engine Mechanical

Standard value

JP30002020205006

Unit : mm {in.}

Inspection item		Standard value	Repair limit	Service limit	Action
Compression pressure		3.4-3.7MPa {35-38kgf/cm ² , 493-237lbf/in. ² }	—	2.7MPa {28kgf/cm ² , 392lbf/in. ² }	
Valve clearance (cold)	IN	0.30 {0.0118}	—	—	
	EX	0.45 {0.0177}	—	—	
Cylinder liner protrusion		0.01 - 0.08 {0.003 - 0.003}	—	—	
Cylinder liner flange width		8 {0.314}	—	—	
Cylinder block flange width		8 {0.314}	—	—	
Cylinder block inner diameter	A	117 - 117.008 {4.6063 - 4.6066}	—	—	
	B	117.008 - 117.014 {4.6066 - 4.6068}	—	—	
	C	117.014 - 117.022 {4.6068 - 4.6072}	—	—	

Inspection item			Standard value	Repair limit	Service limit	Action
Cylinder liner outer diameter	A		116.982 - 116.99 {4.6056 - 4.6059}	—	—	
	B		116.99 - 116.996 {4.6059 - 4.6061}	—	—	
	C		116.996 - 117.004 {4.6061 - 4.6064}	—	—	
Clearance between cylinder liner and cylinder block			0.01 - 0.026{0.0003 - 0.0010}	—	—	
Cylinder liner inner diameter			112{4.4094}	—	112.15 {4.4154}	Cylinder Replace liner
Piston outer diameter (Pin hole 23mm{0.9 in.} above the lower end of the skirt Square direction)			111.9±0.008{4.4089±0.0003}	—	—	
Piston clearance			0.048 - 0.112{0.0044 - 0.0044}	—	—	Cylinder Liner Replace piston
Piston ring	Free joint clearance	Top	Approx. 10.0 {0.3937}	—	—	
		Second	Approx. 12.5 {0.4921}	—	—	
	Cylinder liner Joint for assembly Clearance	Top	0.3 - 0.40 {0.0118 - 0.0157}	—	1.5{0.0591}	Replace piston ring
		Second	0.75 - 0.90 {0.0295 - 0.0354}	—	1.2{0.0472}	
		Oil	0.15 - 0.3 {0.0059 - 0.1181}	—	1.2{0.0472}	
	Ring width B dimension	Top	2.5{0.0984}	—	-0.1 {-0.0039}	Replace piston ring
		Second	2{0.0787}	—	-0.1 {-0.0039}	
		Oil	4{0.1574}	—	-0.1 {-0.0039}	

Inspection item		Standard value	Repair limit	Service limit	Action	
Piston	Piston ring groove	Top	2.5{0.0984}	—	+0.2 {+0.0079}	Replace piston
		Second	2{0.0787}	—	+0.2 {+0.0079}	
		Oil	4{0.1574}	—	+0.1 {+0.0039}	
	Clearance between piston ring and piston ring groove	Top	0.09 - 0.13{0.0035 - 0.0051}	—	—	Replace piston ring or piston.
		Second	0.04 - 0.08{0.00016 - 0.0031}	—	—	
		Oil	0.02 - 0.06{0.0008 - 0.0024}	—	—	
	Piston pin outer diameter		37{1.4567}	—	-0.04 {-0.0015}	Replace piston pin
	Piston boss inner diameter		37{1.4567}	—	+0.05 {+0.0020}	Replace piston
	Clearance between piston pin and piston boss		-0.002T - 0.025{0.0000 - 0.0010}L (T : Tightening allowance, L : Clearance)	—	0.05 {0.0020}	Replace piston pin or piston
Connecting rod bushing inner diameter		37{1.4567}	—	+0.1 {0.0039}	Replace connecting rod bushing	
Connecting rod bushing oil clearance		0.015 - 0.036{0.0006 - 0.0014}	—	0.08 {0.0031}	Replace piston pin or connecting rod bushing	

	Inspection item	Standard value	Repair limit	Service limit	Action
Crankshaft	Crank pin outer diameter	65{2.5590}	—	63.8 {2.5118}	Replace the crankshaft. (Note 1)
	Thickness of connecting rod bearing	2.0{0.0787}	—	—	
	Connecting rod oil clearance	0.031 - 0.082 {0.0012 - 0.0032}	0.2{0.0079}	—	Replace bearing for clearance of 0.3 or more (Note 2)
	Crankjournal outer diameter	80{3.1496}	—	78.8 {3.1024}	Crank Replace shaft (Note 1)
	Thickness of main bearing	2.5{0.2342}	—	—	
	Crankshaft oil clearance	0.051 - 0.102 {0.0020 - 0.0040}	0.2{0.0079}	—	Replace-bearing (Note 2)
	Center journal width	36{1.4173}	—	+1.00 {+0.039}	Replace crankshaft.
	Thickness of thrust bearing	2.5{0.2342}	—	—	
	Crankshaft end play	0.050 - 0.270 {0.0020}	0.50 {0.0020}	1.270 {0.0500}	Replace thrust bearing
	Crankshaft runout	—	0.15 {0.0059}	—	Ground to under-size
	Crank pin width	34{13.386}	—	+0.8 {+0.0315}	Replace crankshaft
<p>Note 1 : Correction with re-grinding for eccentric wear of 0.10 or more. Re-grinding for wear of 0.2 or more. Replace crankshaft for wear of 1.20 or more.</p> <p>Note 2 : Under-size bearing values are 0.25, 0.50, 0.75 and 1.00.</p>					
	Connecting rod large end width	34{1.3386}	—	-0.8 {-0.0315}	Replace connecting rod
	Connecting rod end play	0.20 - 0.52 {0.0079 - 0.0205}	—	1.0{0.0394}	Replace connecting rod or crankshaft

Inspection item		Standard value	Repair limit	Service limit	Action	
Camshaft	Camshaft journal outer diameter	40{1.5748}	—	-0.15 {-0.0059}	Replace camshaft	
	Camshaft bearing inner diameter	40{1.5748}	—	+0.15 {+0.059}	Bearing Replacement	
	Camshaft bearing oil Clearance	0.020 - 0.063 {0.0008 - 0.0025}	—	—	Replace camshaft or bearing	
	Cam height	IN	50.046{1.9703}	—	-0.08 {-0.0031}	Replace camshaft
		EX	52.739{2.0763}	—		
	Cam lift	IN	8.046{0.3168}	—	-0.08 {-0.0031}	Replace camshaft
EX		10.739{0.4228}	—			
Camshaft	Camshaft journal width (Rear journal)	33{1.2992}	—	—		
	Camshaft end play	0.100 - 0.178{0.0039 - 0.0070}	—	—	Replace camshaft	
	Camshaft runout	0.04 {0.0016}	—	0.1{0.039}	Replace camshaft	
Rocker shaft outer diameter		22{0.8661}	—	-0.08 {-0.0031}	Replace rocker shaft	
Rocker arm bushing inner diameter		22{0.8661}	—	+0.08 {+0.0031}	Replace rocker arm bushing	
Rocker arm oil clearance		0.030 - 0.101 {0.00012 - 0.0040}	0.15 {0.0059}	—		
Valve stem outer diameter	IN	7{0.2756}	—	—	Replace valve	
	EX	7{0.2756}	—	—		
Valve guide inner diameter	IN	7{0.2756}	—	—	Replace valve guide	
	EX	7{0.2756}	—	—		
Oil clearance between valve guide and valve stem	IN	0.023 - 0.058 {0.0009 - 0.0020}	—	—	Replace valve or valve guide	
	EX	0.050 - 0.083 {0.0020 - 0.0033}	—	—		
Valve sink	IN	0.55 - 0.85 {0.0217 - 0.0335}	—	1.1{0.0433}	Replace valve and valve seat	
	EX	1.15 - 1.45 {0.0453 - 0.0571}	—	1.7{0.0669}		
Valve seat angle	IN	30°	Allowable angle 30° - 30° 35'		Correction	
	EX	45°	Allowable angle 45° - 30° 30'			
Valve face angle	IN	30°	Allowable angle 29° 30' - 45°			
	EX	45°	Allowable angle 44° 30' - 45°			

Inspection item		Standard value	Repair limit	Service limit	Action	
Valve spring	Inner	Set length	44.8{1.764}	—	—	
		Set load	129N {13.1kgf}	—	—	
		Free length	64.6 {2.5433}	—	-3.0 {-0.3543}	Replace spring
		Squareness	—	—	2.0 {0.0787}	Replace spring
	Outer	Set length	46.8 {1.8252}	—	—	
		Set load	314N {32.0kgf}	—	—	
		Free length	75.7 {2.9803}	—	-3.0 {-0.3543}	Replace spring
		Squareness	—	—	2.0 {0.0787}	Replace spring

Inspection item		Standard value	Repair limit	Service limit	Action	
Timing gear	Back-lash	Crank - Main idle	0.030 - 0.167{0.0012 - 0.0066}	—	0.30 {0.0012}	Gear replacement
		Main idle - Pump drive idle	0.032 - 0.096{0.0013 - 0.0038}	—	0.10 {0.00393}	
		Pump drive idle - Pump drive	0.020 - 0.083{0.0008 - 0.0033}	—	0.10 {0.00393}	
		Main idle - Sub-idle	0.030 - 0.113{0.0012 - 0.0044}	—	0.30 {0.0012}	
		Sub-idle - Oil pump	0.030 - 0.113{0.0012 - 0.0044}	—	0.30 {0.0012}	
		Sub-idle - Cam idle	0.050 - 0.218{0.0020 - 0.0086}	—	0.30 {0.0012}	
		Cam idle - Cam	0.030 - 0.253{0.0012 - 0.0100}	—	0.30 {0.0012}	
	Main idle	Shaft outer diameter	57{2.2441}	—	—	
		Bushing inner diameter	57{2.2441}	—	—	
		Clearance between shaft and bushing	0.030 - 0.090{0.0012 - 0.0084}	—	0.20 {0.0079}	Replace shaft or bushing
		Gear width	44{1.7322}	—	—	
		Shaft length	44{1.7322}	—	—	
		End play	0.114 - 0.160{0.0045 - 0.0063}	—	0.30 {0.0012}	Replace shaft or gear
	Sub-idle	Shaft outer diameter	50{1.9685}	—	—	
		Bushing inner diameter	50{1.9685}	—	—	
		Clearance between shaft and bushing	0.025 - 0.075{0.0010 - 0.0030}	—	0.20 {0.0079}	Replace shaft or bushing
		Gear width	22{0.8661}	—	—	
		Shaft length	22{0.8661}	—	—	
End play		0.040 - 0.120{0.0016 - 0.0047}	—	0.30 {0.0012}	Replace shaft or gear	

Inspection item		Standard value	Repair limit	Service limit	Action	
Timing gear	Cam idle	Shaft outer diameter	34{1.3386}	—	—	
		Bushing inner diameter	34{1.3386}	—	—	
		Clearance between shaft and bushing	0.025 - 0.075 {0.0002 - 0.0030}	—	0.20 {0.0079}	Replace shaft or bushing
		Gear width	22{8.6614}	—	—	
		Shaft length	22{8.6614}	—	—	
		End play	0.040 - 0.120 {0.0016 - 0.0047}	—	0.30 {0.0012}	Replacethrust plate or gear
	Pump drive idle	Shaft outer diameter	34{1.3386}	—	—	
		Bushing inner diameter	34{1.3386}	—	—	
		Clearance between shaft and bushing	0.025 - 0.057 {0.0002 - 0.0022}	—	0.10 {0.0039}	Replace shaft or bushing
		Gear width	28.5{0.9605}	—	—	
		Shaft length	28.5{0.9605}	—	—	
		End play	0.016 - 0.22 {0.0006 - 0.0087}	—	—	
Flatness under cylinder head		Longitudinal direction 0.06{0.0024} Square direction 0.03{0.0012}	—	0.20 {0.0079}	Grinding is inhibited because backlash between cam idle – sub-idle gears is changed.	
Flatness above cylinder block		0.05{0.0020}	—	0.20{0.0079}		
Surface runout of flywheel		—	0.15 {0.0060}	—		
Camshaft gear mounting bolt		—	—	30.5{1.2010}	Replacement	
Bearing cap bolt (Crankshaft mounting)		—	—	108{4.2520}	Replacement	
Connecting rod bolt		—	—	68.0{2.6772}	Replacement	
Head bolt		—	—	126.5 {49.8031}	Replacement	

Valve timing

Exhaust valve open (before BDC)	59°
Exhaust valve close (after BDC)	13°
Intake valve open (before BTC)	13°
Intake valve close (after BTC)	21°

Tightening torque

JP30002020205007

Unit : N·m{kgf·cm, lbf·ft}

Tightening area	Tightening torque	Remark
Crankshaft pulley mounting bolt	118{1,203, 87}	
Head cover mounting bolt	28.5{290, 21}	
Camshaft bearing cap mounting bolt	31{320,23}	
Union bolt of leakage pipe	13.5{135, 10}	
Injector harness mounting nut	28{290, 21}	
Camshaft gear mounting bolt	59{600, 44}+90°	
Camshaft housing mounting bolt	23{230, 17}	
Cylinder plug mounting torx bolt	6{60, 4}	
Rocker arm adjusting screw lock nut	25{250, 18}	
Rocker arm support bolt	59{600, 44}	
Head bolt	59{600, 44}+90° +90°	
Cam idle gear shaft mounting bolt	108{1,100, 80}	
Main bearing cap mounting bolt	69{700, 51}+90° +45°	Refer to the main text.
Connecting rod cap mounting nut	69{700, 51}+90° +45°	
Oil check valve	22{220, 16}	
Sub-idle gear shaft mounting bolt	108{1,100, 80}	
Main idle gear shaft mounting bolt	172{1,750, 127}	
Flywheel mounting bolt	186{1,900, 137}	
Flywheel housing mounting bolt	196{2,000, 145}	M16
	55{560, 41}	M10
	36{370, 27}	M8
Flywheel housing stay - Cylinder block	97{990, 72}	M12
Flywheel housing stay - Flywheel housing	171.5{1, 750, 126}	M14
Rear end plate torx bolt	55{560, 41}	
Supply pump bearing case mounting bolt	28.5{290, 21}	
Pump drive idle gear shaft mounting bolt	108{1,100, 80}	

Exhaust

Tightening torque

JP30002020205008

Unit : N · m {kgf · cm, lbf · ft}

Tightening area	Tightening torque	Remark
Exhaust manifold mounting nut	53{540, 40}	
Exhaust pipe mounting nut	70±14{715±140, 52±10}	

Cooling

Standard value

JP30002020205009

Inspection item	Standard value	Repair limit	Service limit	Action
Thermostat valve open temperature	74.5 - 78.5 °C {166.1 - 173.3 °F}	—	—	Replacement
Thermostat valve lift (Set temperature 95 °C)	13mm {0.5118 in.} or more	—	—	Replacement

Lubrication

Standard value

JP30002020205010

Unit : mm {in.}

Inspection item	Standard value	Repair limit	Service limit	Action
Hydraulic alarm switch operation pressure	39kPa {0.4kgf/cm ² , 5.66lbf/in. ² }	—	—	

Inspection item		Standard value	Repair limit	Service limit	Action
Oil pump	Outer diameter of drive gear	54{2.1260}	—	—	
	Cylinder block side Oil pump chamber inner diameter	54{2.1260}	—	—	
	Clearance between drive gear and cylinder block	0.100 - 0.202 {0.0039 - 0.0080}	—	0.30 {0.0118}	Replace drive gear or oil pump
	Drive gear width	37.5{1.4764}	—	—	
	Cylinder block side Depth of oil pump chamber	37.5{1.4764}	—	—	
	Drive gear end play	0.049 - 0.113 {0.00193 - 0.0044}	—	0.15 {0.059}	Replace drive gear or oil pump
	Outer diameter of driven gear shaft	18{0.7087}	—	—	
	Cylinder block hole diameter	18{0.7087}	—	—	
	Clearance between drive gear shaft outer diameter and bushing inner diameter at cylinder block side	0.040 - 0.099 {0.0016 - 0.0039}	—	—	Replace drive gear or bushing
	Outer diameter of driven gear shaft	18{0.7087}	—	—	
	Cylinder block hole diameter	18{0.7087}	—	—	
	Clearance between driven gear shaft outer diameter and cylinder block hole diameter	0.030 - 0.075 {0.0012 - 0.0030}	—	—	Replace oil pump
	Outer diameter of driven gear shaft	18{0.7087}	—	—	
	Inner diameter of driven gear bushing	18{0.7087}	—	—	
	Clearance between driven gear shaft outer diameter and gear bushing inner diameter	0.040 - 0.083 {0.016 - 0.0033}	—	0.15 {0.059}	Replace oil pump or bushing
	Backlash between drive gear and driven gear	0.073 - 0.207 {0.0029 - 0.0082}	—	0.30 {0.0118}	Replace oil pump

Tightening torque

JP30002020205011

Unit : N·m{kgf·cm, lbf·ft}

Tightening area		Tightening torque	Remark
Oil pan mounting bolt		30{300, 22}	
Oil strainer		31{320, 23}	
Oil pan drain cock		41{420, 30}	
Oil pump mounting bolt		28.5{290, 21}	
Oil cooler	Oil circuit spring plug	M14	24.5±4.9{250±50, 18±4}
		M20	24.5±4.9{250±50, 18±4}
		M22	29.4±4.9{300±50, 22±4}
		M24	34.3±4.9{350±50, 25±4}
	Coolant drain plug	44.1±4.9{450±50, 33±4}	
Oil cooler case assembly mounting bolt		24.5±4.9{250±50, 18±4}	

Starting and Charging

Standard value (alternator 60A)

JP30002020205012

Inspection item		Standard value	Repair limit	Service limit	Action
Resistance between stator coil terminals (for 2 phases)		0.15 - 0.17Ω	—	—	Replacement
Resistance between stator coil core and coil		1MΩ or more	—	—	Replacement
Resistance of feed coil		6.4 - 7.0Ω	—	—	Replacement
Resistance between feed coil core and coil		1MΩ or more	—	—	Replacement
Shaft outer diameter of rotor assembly	Front	25mm {0.9843 in.}	—	24.98mm {0.9835 in.}	Replacement
	Rear	17mm {0.6693 in.}	—	16.98mm {0.6685 in.}	
Resistance between diode and rectifier holder	Forward resistance value	Approx. 10Ω	—	—	Replacement
	Reverse resistance value	Infinite	—	—	
Resistance between regulator terminals F — E	Forward resistance value	Approx. 10Ω	—	—	Replacement
	Reverse resistance value	Infinite	—	—	

Tightening torque (alternator 60A)

JP30002020205013

Unit : N · m {kgf · cm, lbf · ft}

Tightening area	Tightening torque	Remark
E terminal bolt	3.2 - 4.4{33 - 45, 2 - 3}	
Fixing bolt at brace	51{520, 38}	
Alternator mounting through bolt	83{850, 61}	
Bearing cover mounting bolt	1.9 - 2.5{20 - 25, 1 - 2}	
Pulley mounting nut	127 - 157{1, 300 - 1, 600, 94 - 116}	
Feed coil mounting bolt	2.9 - 3.9{30 - 39, 2 - 3}	
Rectifier and regulator mounting bolt	1.9 - 2.5{20 - 25, 1 - 2}	
Inside B terminal mounting nut	4.9 - 5.9{50 - 60, 4 - 4}	
Outside B terminal mounting nut	3.2 - 4.4{33 - 45, 2 - 3}	
Through bolt	7.8 - 9.8{80 - 99, 6 - 7}	
Coupler holder mounting bolt	1.9 - 2.5{20 - 25, 1 - 2}	
Cover mounting bolt	3.3 - 4.4{34 - 44, 2 - 3}	

Standard value (starter)

JP30002020205014

Unit : mm {in.}

Inspection item		Standard value	Repair limit	Service limit	Action
Yoke assembly	Resistance between coil lead wire and yoke	—	—	1k Ω or less	Replace yoke assembly
	Brush length	18{0.7087}	—	13{0.5118} or less	Replace brush
Armature assembly	Resistance between commutator and core	1M Ω or more	—	1k Ω or less	Replace armature assembly
	Commutator outer diameter	36{1.4173}	—	34{1.1458} or less	
	Shaft outer diameter A	12{0.4724}	—	11.98{0.4717} or less	
	Shaft outer diameter B	9{0.3643}	—	8.98{0.3535} or less	
	Undercut depth	0.5 - 0.8{0.0197}	—	0.2{0.0079} or less	Correction
Holder assembly	Resistance between holder and plate	—	—	1k Ω or less	Replace holder assembly
	Brush length	18{0.7087}	—	13{0.5118} or less	Replace brush
Shaft assembly outer diameter	A	26{1.0236}	—	25.90{1.0197} or less	Replace shaft assembly
	B	12.1{0.4764}	—	12.04{4.7401} or less	
Clutch assembly inner sleeve outer diameter		25{0.9843}	—	24.90{0.9803} or more	Replacement
Metal bushing inner diameter of pinion case		25{0.9843}	—	25.2{0.9921} or more	Replace pinion case
Metal bushing inner diameter of center bracket		26{1.02362}	—	26.2{1.0315}	Replace center bracket
Metal bushing inner diameter of shaft assembly		9{0.3543}	—	9.2{0.3622}	Replace shaft assembly
Bearing housing inner diameter of rear bracket		28{1.1024}	—	28.1{1.1063} or more	Replace rear bracket
Start magnet switch assembly	Between C terminal and M terminal (P coil)	0.12 - 0.15 Ω	—	—	Replace start magnet switch assembly
	Between C terminal and body (H coil)	1.08 - 1.32 Ω	—	—	

Tightening torque (starter)

JP30002020205015

Unit : N · m{kgf · cm, lbf · tt}

Tightening area	Tightening torque	Remark
Starter mounting nut	171.5{1,750, 126}	
C lead wire mounting bolt	2 - 3{19 - 25, 1 - 2}	
M lead wire mounting nut	12.3 - 15.2{126 - 154, 9 - 11}	
Rear bracket mounting through bolt	15.7 - 17.6{160 - 179, 12 - 13}	
Brush holder fixing bolt of rear bracket	3.6 - 4.9{37 - 49, 3 - 4}	
Start magnet switch assembly mounting bolt at pinion case	3.6 - 4.9{37 - 49, 3 - 4}	
Battery cable mounting nut	16 - 22{165 - 225, 11 - 16}	

Turbocharger**Standard value**

JP30002020205016

Unit : mm {in.}

Inspection item	Standard value	Repair limit	Service limit	Action
Turbine shaft play	0.040 - 0.085 {0.0016 - 0.0033}	—	—	

Tightening torque

JP30002020205017

Unit : N · m{kgf · cm, lbf · tt}

Tightening area	Tightening torque	Remark
Turbocharger mounting nut	56 {570, 41}	

3 PARTS TO BE PREPARED



3

Engine Body	3-2
Special tool	3-2
Fuel System	3-2
Lubricant, etc.	3-2
Engine Mechanical	3-3
Special tool	3-3
Instruments	3-6
Lubricant, etc.	3-6
Lubrication	3-6
Special tool	3-6
Lubricant, etc.	3-6
Starting and Charging	3-7
Special tool	3-7
Jig (reference dimensional drawing for manufacture)	3-7
Instruments	3-8
Lubricant, etc.	3-8
Turbocharger	3-8
Special tool	3-8
Engine Failure Diagnosis	3-9
Special tool	3-9

Engine Body

Special tool

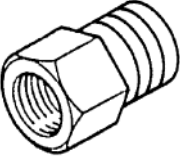
JP30002030901001

Shape	Part No.	Description	Remark
	Suitable Tool	Wire rope	For engine lifting
	380100024	Compression gauge adapter	
	380100025	Compression gauge adapter	
	380100026	Compression gauge adapter	

Fuel System

Lubricant, etc.





JP30002030901002



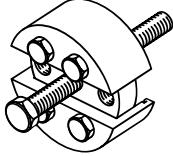
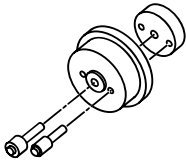
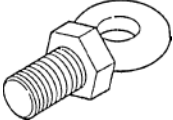

Name	Remark
Guide bolt 380100027	For supply pump positioning

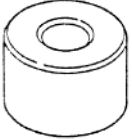
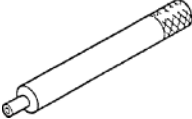
Engine Mechanical

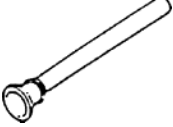
Special tool

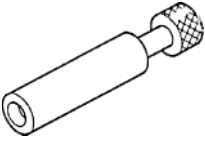
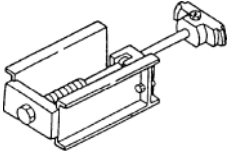
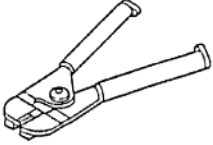
JP30002030901003

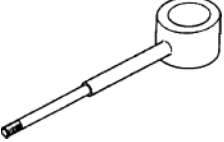
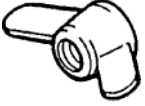
Shape	Part No.	Name	Remark
	380100028	Oil seal puller	For crankshaft front oil seal removal
	380100029	Oil seal press	For crankshaft front oil seal press-fit
	Suitable Tool	Eye bolt	For assembly/disassembly of cylinder head
	Suitable Tool	Valve spring press	For assembly/disassembly of valve spring retainer
	380100030	Guide	For valve guide press-fit
	380100031	Bar	For nozzle seat clamping
	380100032	Steel ball	For nozzle seat clamping (together with 09472-1210)
	Suitable Tool	Valve lapping tool	For valve adjustment

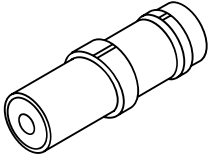
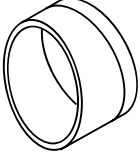
Shape	Part No.	Name	Remark
	380100033	Bar	For valve stem seal mounting
	Suitable Tool	Cylinder liner puller	For removal and inspection of cylinder liner
	Suitable Tool	Piston ring expander	For assembly/disassembly of piston ring
	Suitable Tool	Bolt	For mounting of connecting rod small end bushing (together with 09402-1480 or 09402-1540)
	Suitable Tool	Press sub-assembly	For assembly/disassembly of connecting rod small end bushing
	Suitable Tool	Wing nut	For assembly/disassembly of connecting rod small end bushing (together with 09402-1530)
	Suitable Tool	Guide	For assembly/disassembly of connecting rod small end bushing (together with 09402-1530)
	Suitable Tool	Spindle	For assembly/disassembly of connecting rod small end bushing
	Suitable Tool	Guide	For mounting of connecting rod small end bushing (together with 09402-1540)

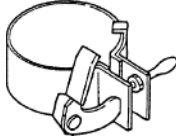
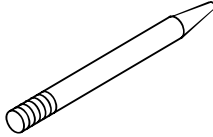
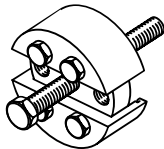
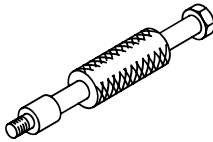
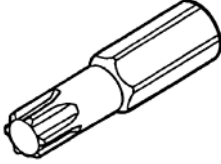
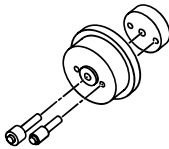
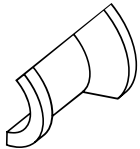
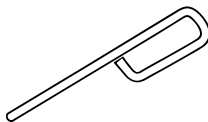
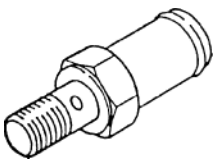
Shape	Part No.	Name	Remark
	Suitable Tool	Piston ring holder	For piston mounting
	Suitable Tool	Guide	For assembly/disassembly of flywheel
	0380100034	Oil seal puller	For crankshaft rear oil seal removal
	380100035	Sliding hammer	For main/sub idle gear assembly and cam idle gear shaft removal
	380100036		
	380100037	Socket wrench	For assembly/disassembly of Torx bolt
	380100038	Oil seal press	For crankshaft rear oil seal press-fit
	Suitable Tool	Guide	For insertion of cylinder liner
	0380100039	Tool	For cooling jet repair
	380100040	Check bolt	For cooling jet inspection and adjustment

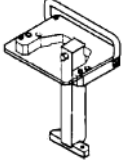
Shape	Part No.	Name	Remark
	380100041	Tool assembly	For cooling jet inspection and adjustment

Instruments

JP30002030901004

Name	Remark
Micrometer	For measurement of part outer diameter
Cylinder gauge	For measurement of part inner diameter
Thickness gauge	For measurement of each clearance
Dial gauge	For measurement of parts

Lubricant, etc.

JP30002030901005

Name	Remark
Liquid gasket (Threebond TB1207B or equivalent : Black)	For sealing of parts
Liquid gasket (Threebond TB1207D or equivalent : Silver)	For sealing of parts
Liquid gasket (Threebond TB1211 or equivalent : White)	For sealing of parts
Red lead	Valve adjustment
Dye penetrant	For inspection of crack

Lubrication

Special tool

JP30002030901006

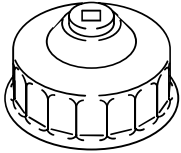
Shape	Part No.	Name	Remark
	Suitable Tool	Oil filter wrench	

Lubricant, etc.

JP30002030901007

Name	Remark
Liquid gasket (Threebond TB1207D or equivalent : Silver)	For sealing of parts
Liquid gasket (Threebond TB1211 or equivalent : White)	For sealing of parts

Starting and Charging

Special tool

JP30002030901008

Alternator

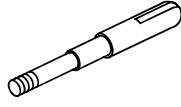
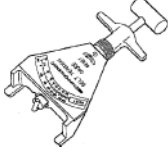
Shape	Part No.	Name	Remark
	380100042	Compression gauge	For V-belt tension adjustment
	380100043	Belt tension gauge	For V-belt tension adjustment

Jig (reference dimensional drawing for manufacture)

JP30002030901009

This is used for assembly of bearing. Reference dimensions are shown in the figures below:

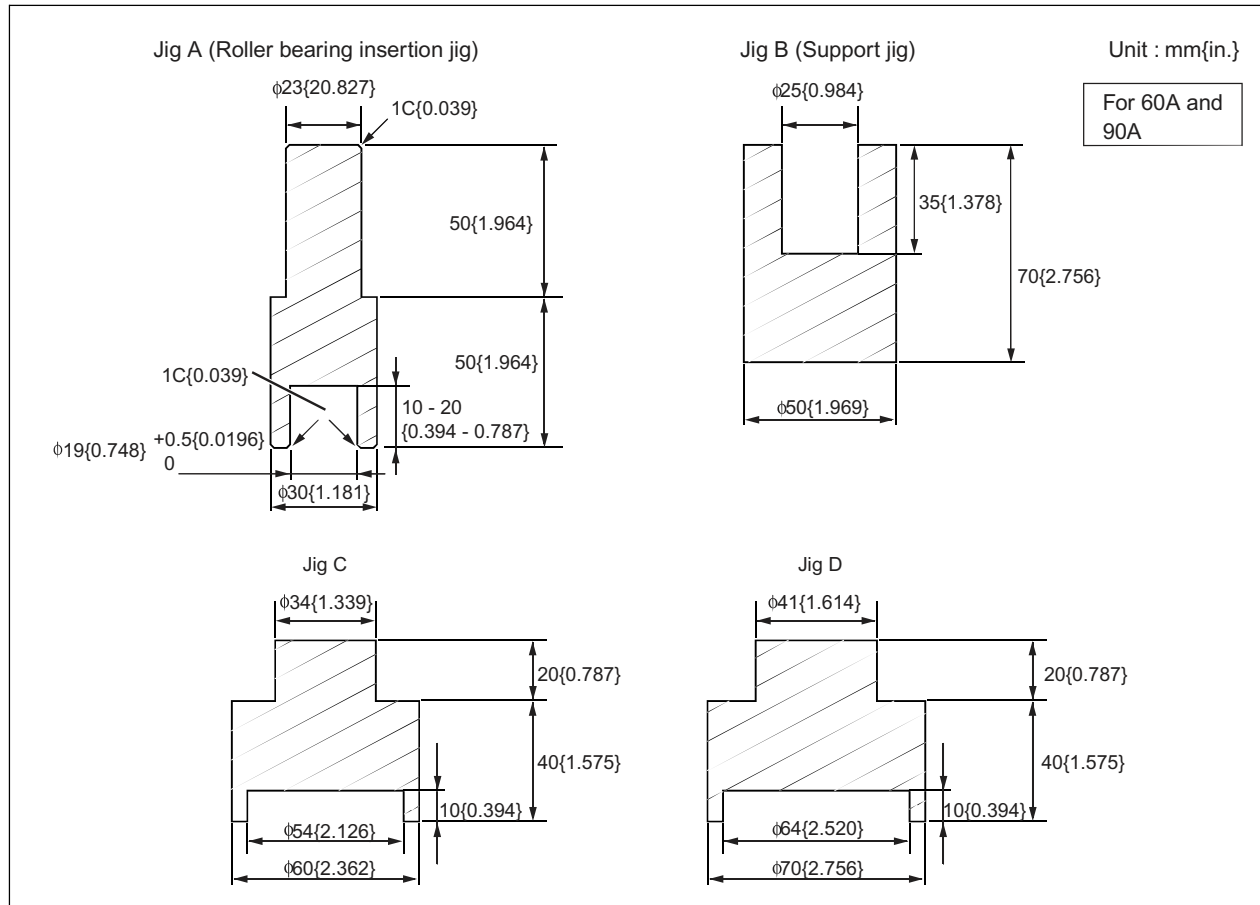

SAPH300020300034

Instruments

JP30002030901010

Alternator

Name	Remark
Circuit tester	For measurement of parts
Micrometer	For measurement of parts
Regulator checker (G&M Machinery ICD-101D or equivalent)	For inspection of regulator

Starter

Name	Remark
Circuit tester	For measurement of parts
Micrometer	For measurement of part outer diameter
Growler tester	For inspection of armature
Cylinder gauge	For measurement of part inner diameter

Lubricant, etc.

JP30002030901011

Name	Remark
Kyodo Yushi Multemp AC-N	For lubrication of parts
Nisseki Mitsubishi Pyroknock #2	For lubrication of parts

Turbocharger**Special tool**



JP30002030901012

Shape	Part No.	Name	Remark
	380100044	Tool assembly	

Engine Failure Diagnosis

Special tool

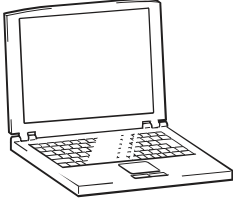
JP30002030901013

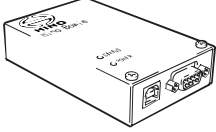
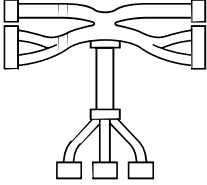
Shape	Part No.	Name	Remark
	-	Personal computer (DOS-V)	<ul style="list-style-type: none"> Operating system(OS):Windows95, Windows98(IE5.0 or later), Windows2000(SP3, IE5.0 or later), WindowsXP(SP1a, IE6.0 or later) CPU and memory: Conditions that assure operation of the above operating system Display: 800 x 600, 256 colors or more
		Hino-DX	Failure diagnosis software (CD-ROM)
	380100046	Hino-Bowie (Interface box)	Used together with the cable between the vehicle and Hino-Bowie 380100047
	380100048	Signal check harness	This is installed as interruption between vehicle harness and the ECU. Tester inspection is allowed in energized status.

4 ENGINE ASSEMBLY/DISASSEMBLY

Inspection Before Service	4-2
Measurement of compression pressure	4-2
Engine Body.....	4-3
Removal.....	4-3
Installation.....	4-5
Work after installation	4-5

Inspection Before Service

Measurement of compression pressure

JP30002040702001

- NOTICE**
- Measure the compression pressure before disassembly of the engine and record the result. Regular measurement of the compression pressure can tell the engine status.

1. Preparation before measurement

- (1) Charge the battery completely.
- (2) Check the valve clearance and adjust it when exceeding the standard value.
- (3) Warm the engine and set the water temperature to 80 °C {176 °F}.
- (4) Remove the air cleaner.
- (5) Remove the head cover.
- (6) Remove all injectors.
- (7) To prevent spread of engine oil, attach a jig which cuts a head cover in half. (Cut it so that the camshaft may be covered).

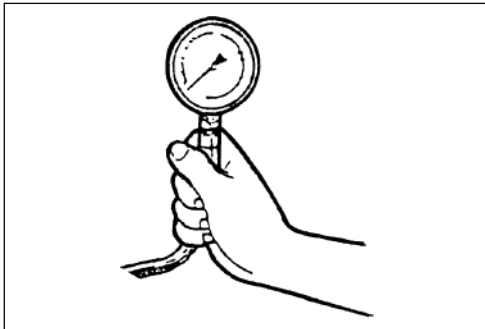

SAPH300020400001

2. Measurement

- (1) Attach a special tool to the nozzle sheet of the cylinder where the compression pressure is measured.
Special tool : 380100026, 380100025, 380100024
Compression gauge adapter
- (2) Turn the starter and measure the compression pressure.

- ! CAUTION**
- Do not operate the starter for 15 seconds or more.
 - Since the air cleaner is removed, prevent entry of dirt.

- (3) Measure the compression pressure of each cylinder continuously.

Engine revolution 150r/min {rpm}

	Compression pressure: Unit MPa {kgf/cm ² , lbf/in. ² }
Standard value	2.9 - 3.1 {30 - 32, 421 - 450}
Service limit	2.3 {24, 334}
Difference between cylinders	0.3{3, 44} or less

- (4) If the compression pressure is the service limit or less or if the difference between cylinders is over the standard value, overhaul the engine.
- (5) After measurement, reassemble the removed parts.

Engine Body

Removal

JP30002040702002

1. Preliminary work before removal of engine

- (1) Place the vehicle on a level ground.
- (2) Block tires with scotch.
- (3) Remove the battery cable from the battery minus terminal.

2. Drain of coolant and engine oil

- (1) Drain coolant from the radiator drain cock and the oil cooler drain plug.

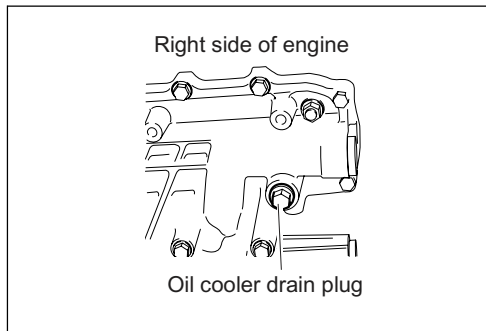

NOTICE

- Removal of the filler cap facilitates quick drain.
- Connection of an appropriate hose to the oil cooler drain pipe facilitates drain of coolant without spread.



CAUTION

- To prevent burn, drain coolant after the temperature is sufficiently low.
- To dispose coolant, observe the specified method (waste disposal) or the method with attention to environment.

- (2) Drain engine oil from the oil pan drain plug as required.



CAUTION

- To prevent burn, drain coolant after the temperature is sufficiently low.
- Dispose coolant according to the specified method (waste treatment) or with a method considering the environment.

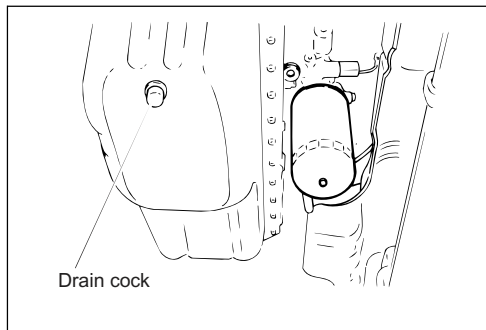

3. Removal of intake hose, intercooler hose and exhaust pipe

- (1) Loosen the clamp and remove the intake hose.
- (2) Remove nuts and remove the exhaust pipe.



CAUTION

- Close the opening of the intake manifold with a packing tape to prevent entry of dirt inside the engine.

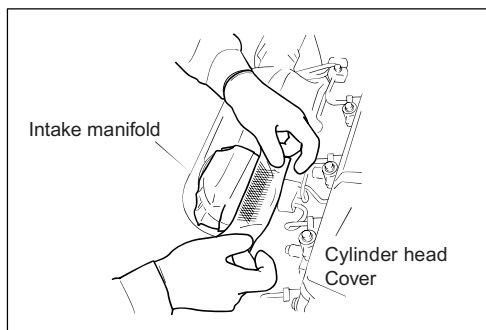

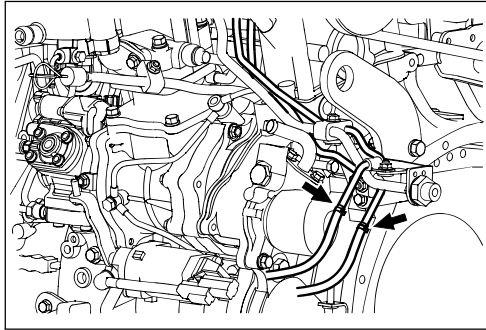

SAPH300020400005

4. Disconnection of fuel hose

- (1) Remove the fuel hoses (feed side and return side). Wrap the removed hose with a plastic sheet with its end facing upward to prevent spill of fuel.

⚠ CAUTION • Wipe spilled fuel with a rag.

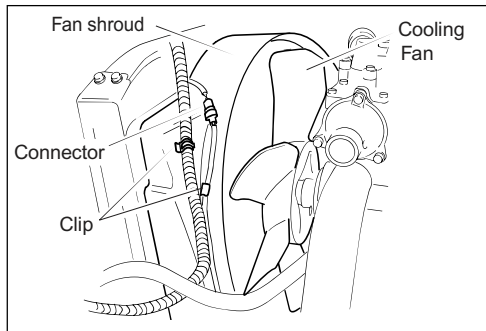

SAPH300020400006

5. Disconnection of water, engine oil pipes, etc.

- (1) Disconnect the hose between the radiator and the engine.
- (2) Disconnect the car heater pipe.
- (3) Disconnect the oil filter pipe.

⚠ CAUTION • Wipe off spilled water and engine oil with waste.

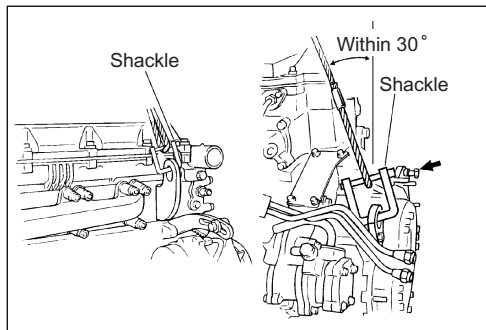

SAPH300020400007

6. Engine lifting

- (1) Attach a tool to the front of the engine and to the left of the flywheel housing.

NOTICE • For 3-point lifting, place a wire rope on the bolts as shown by the arrow in the figure.

- (2) Place a commercially available shackle and a wire rope
- (3) Keep a little slack of the wire rope.

⚠ CAUTION • Keep the wire inclination 30° from the vertical line.

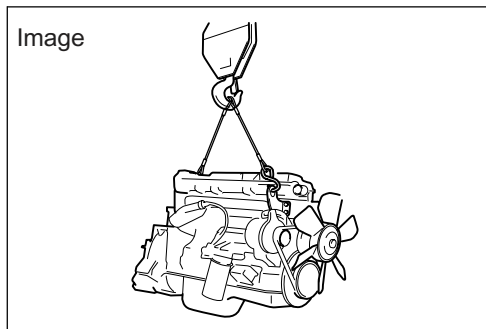

SAPH300020400008

- (4) When the wire is completely tense, make sure that the wire is firmly engaged with the engine hanger. Then, lift the engine slowly.

⚠ CAUTION • Work carefully so that the engine may not come in contact with the frame and others.

Installation

JP30002040702003

1. Connection of fuel hose

- (1) Insert a fuel hose and fix it with a hose band.

Work after installation

JP30002040702004

1. Inspection of engine oil

- (1) Make sure that the drain cock is closed.
- (2) Pour engine oil.

Engine oil amount (L{us gal})

Oil pan	Oil filter
Approx. 26{6.87}	Approx. 1.7{0.45}

**Hino genuine Blue Ribbon ePRO-extra
SAE # 10W-30**

**Hino genuine Blue Ribbon ePRO-super
SAE # 30**

- ⚠ CAUTION**
- Check the amount of oil with an oil level gauge.
 - Vehicles with the DPR (Diesel Particulate Reduction cleaner) must use the specified (recommended) brand engine oil to maintain the function of the DPR for a long time.

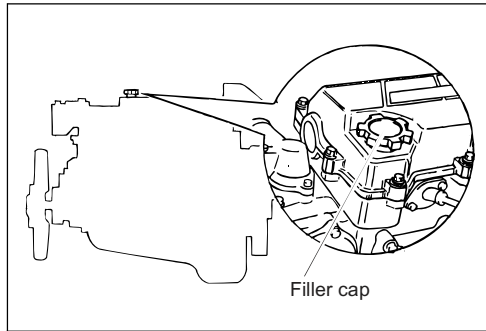

SAPH300020400009

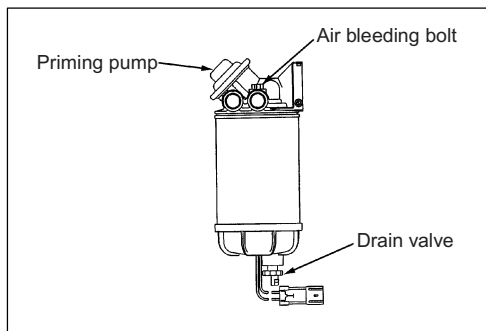

SAPH300020400010

2. Air bleeding of fuel system

- (1) Prepare a rag to receive fuel at the end of the drain valve.
- (2) Loosen the air bleeding plug of the fuel filter.
- (3) Turn the priming pump to the left and lift and move it front and back.
- (4) Move the pump until fuel without bubble comes out from the drain valve.
- (5) Tighten the air bleeding bolt.

Tightening torque :

1.7 - 2.6 N · m {17.3 - 23 kgf · cm, 1.2 - 1.9 lbf · ft}

- (6) Move the priming pump again 5 to 6 times.
- (7) Press the priming pump and tighten it fully to the right.

- ⚠ CAUTION**
- After work, wipe off spilled fuel. After start of the engine, make sure that there is no fuel leak.

5 FUEL SYSTEM

Fuel System	5-2
Fuel system diagram.....	5-2
Part layout.....	5-3
Fuel filter drain (on machine main unit).....	5-4
Replacement of fuel filter element (on machine main unit)	5-5
Replacement of supply pump	5-6
Inspection of supply pump	5-9
Replacement of injector	5-9
Inspection of injector.....	5-11
Replacement of common rail	5-11
Inspection of common rail	5-12

Fuel System

Fuel system diagram

JP30002050402001

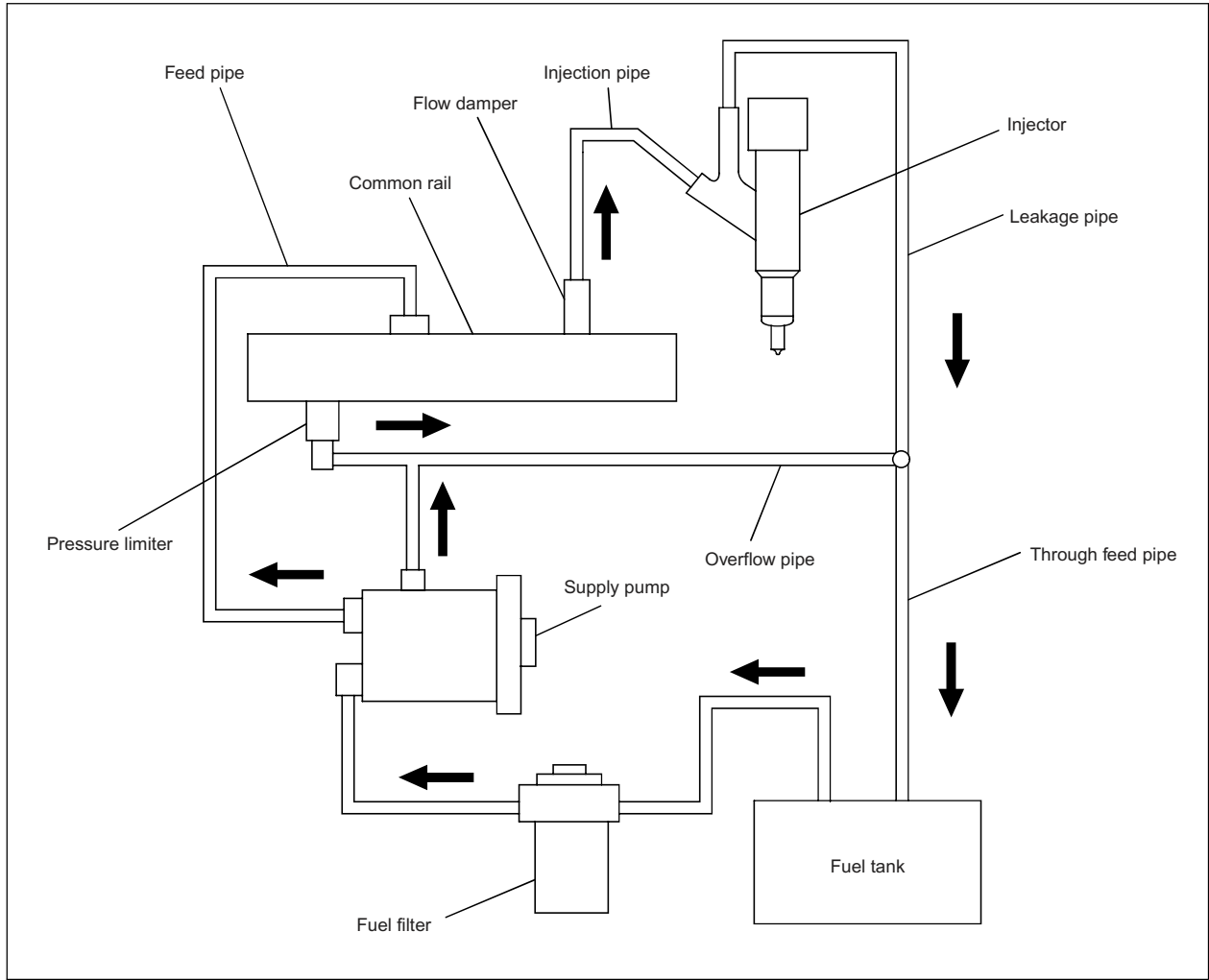

SAPH300020500001

Fuel filter drain (on machine main unit)

JP30002050704001

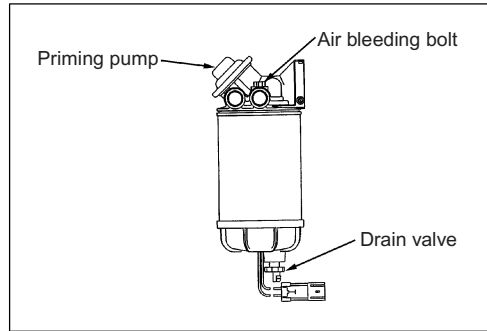

1. Prepare a water container under the drain pipe.
2. Loosen the fuel filter air bleeding bolt and the drain valve.
Discharge water at the bottom of the fuel filter case.

⚠ CAUTION • Since discharged water contains fuel, observe the local disposal procedure for disposal.

3. Close the drain valve.

4. Start the priming pump and bleed air from the system.

⚠ CAUTION • Make sure that the fuel filter air bleeding bolt is loose.

5. Tighten the fuel filter air bleeding bolt.

Tightening torque :

1.7 - 2.6 N · m {17.3 - 23 kgf · cm, 1.2 - 1.9 lbf · ft}

⚠ CAUTION • After work, wipe off spilled water or fuel.
After start of the engine, make sure that there is no fuel leak.

Replacement of fuel filter element (on machine main unit)

JP30002050704002

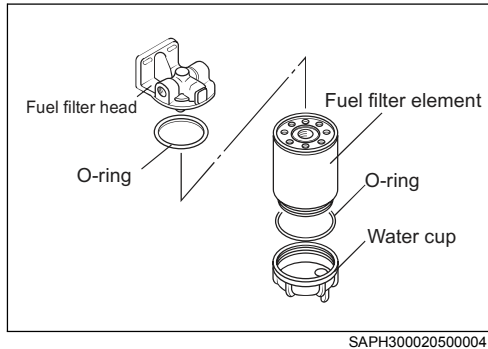

SAPH300020500004

1. Removal of water cup

- (1) Refer to "Drain of the fuel filter" and discharge water from the fuel filter.
- (2) Remove the water cup of the fuel filter.

2. Removal of fuel filter element

- (1) Remove the fuel filter element.

⚠ CAUTION • Since the filter contains diesel oil, prepare a tray.

3. Installation of fuel filter element

- (1) After the O-ring of the fuel filter touches the fuel filter head, turn the fuel filter element by $3/4$ to $1 \cdot 1/2$ and install the fuel filter element on the fuel filter head.
- (2) After the O-ring of the water cup touches the fuel filter element, turn the water cup by $1/2$ to $3/4$ and install the water cup of the fuel filter on the lower part of the fuel filter element.
- (3) Mount the water cup of the fuel filter under the fuel filter element.
- (4) Tighten the fuel filter drain valve.

⚠ CAUTION • Element is not reused.

- (5) Start the priming pump and bleed air from the system.

⚠ CAUTION • Make sure that the fuel filter air bleeding bolt is loose.

- (6) Tighten the fuel filter air bleeding bolt.

Tightening torque :

1.7 - 2.6 N · m {17.3 - 23 kgf · cm, 1.2 - 1.9 lbf · ft}

⚠ CAUTION • After work, wipe off spilled fuel. After start of the engine, make sure that there is no fuel leak.

Replacement of supply pump

JP30002050704003

1. Compression upper dead center setting of No.1 cylinder

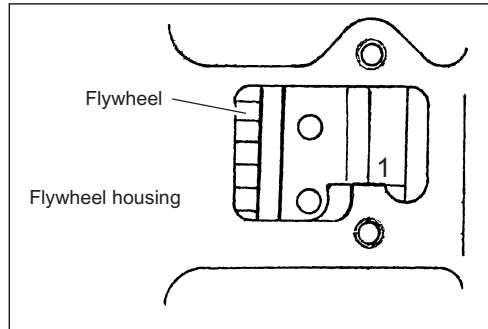

SAPH300020500005

- (1) Turn the crankshaft counterclockwise when viewed from the flywheel. Set the timing mark in the flywheel housing inspection window to "1".

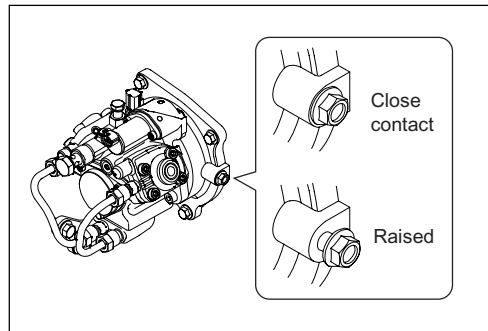

SAPH300020500006

- (2) Remove the inspection window plug in the bearing holder case of the supply pump. Tighten the guide bolt (380100027) very gently and make sure that the bolt seating comes in close contact with the bearing holder.

⚠ CAUTION • If it is raised, there must be contact other than the stopper key for the coupling flange. Do not tighten hard.

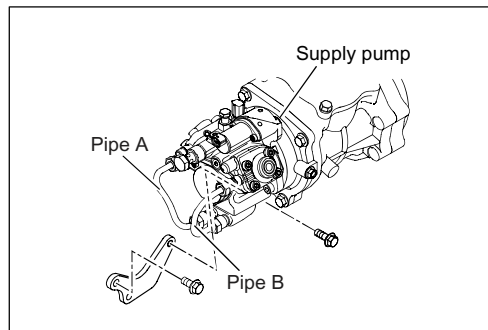

SAPH300020500007

2. Removal of supply pump

- (1) Remove the fuel pipe connected to the supply pump.

⚠ CAUTION • Do not remove pipes A and B.

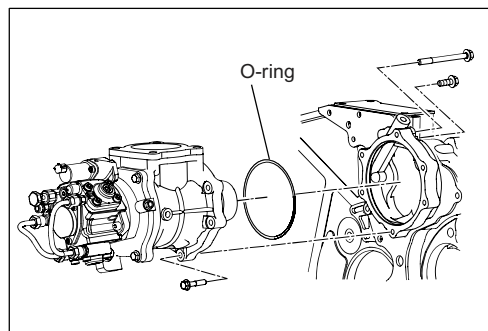

SAPH300020500008

- (2) Remove the supply pump together with the supply pump drive.
- (3) Remove the supply pump at the bearing holder case from the supply pump drive.

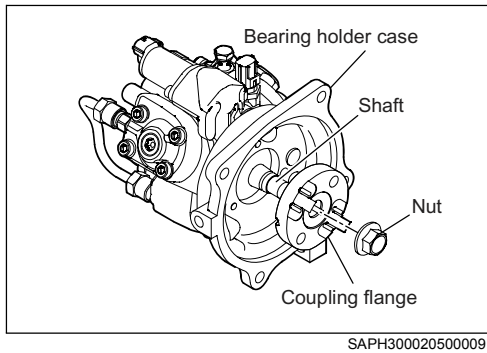

- (4) Fix the coupling flange with a vice to prevent turning and remove the coupling flange.
- (5) Remove the bearing holder case from the supply pump.

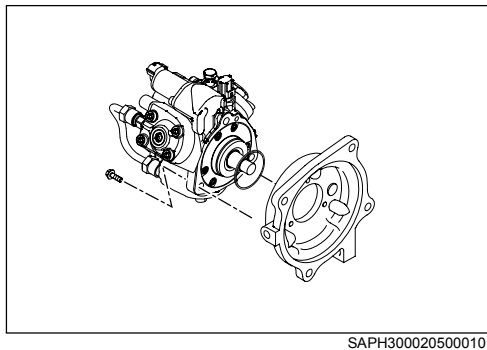

3. Assembly of supply pump and bearing holder case

- (1) Fit a new O-ring to the supply pump and install the bearing holder case.

Tightening torque : 28.5 N·m {290 kgf·cm, 21 lbf·ft}

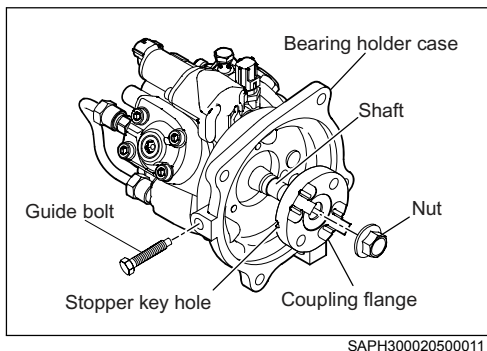

- (2) Fix the supply pump and install the coupling flange to the shaft. Tighten nuts while fixing with a vice to prevent turning.

Tightening torque : 63.7 N·m {650 kgf·cm, 47 lbf·ft}

⚠ CAUTION • Do not use the guide bolt for stopper key of the shaft.

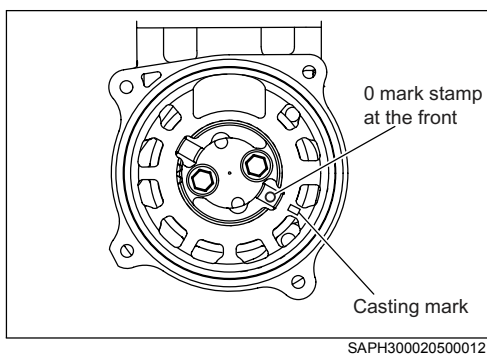

4. Installation of supply pump

- (1) Match the casting mark of the supply pump drive with the "0" mark stamped at the front of the coupling.

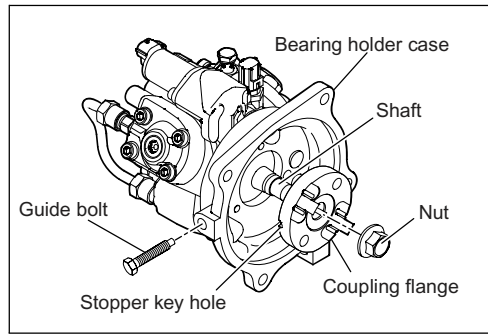

SAPH300020500013

- (2) Put the guide bolt 380100027 into the bearing holder case to come in contact with the stopper key hole of the coupling flange.

CAUTION • Do not tighten the guide bolt by contact not with the stopper key hole of the coupling or do not use the stopper key with the non-specified guide bolt. The specified guide bolt is designed to prevent contact of the guide bolt end with the deep end of the stopper key hole. (The end clearance is 2 mm{0.0788in.})

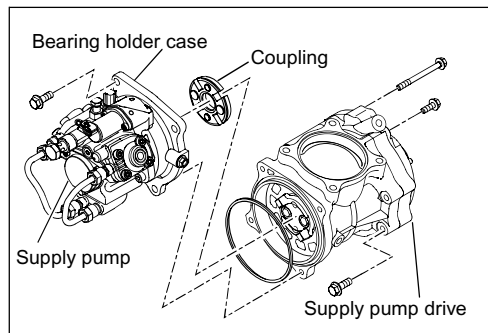

SAPH300020500014

- (3) Replace the O-ring of the supply pump drive and the supply pump with new O-rings and attach couplings for assembly. Then, tighten bolts.

Tightening torque : 28.5 N · m {290 kgf · cm, 21 lbf · ft}

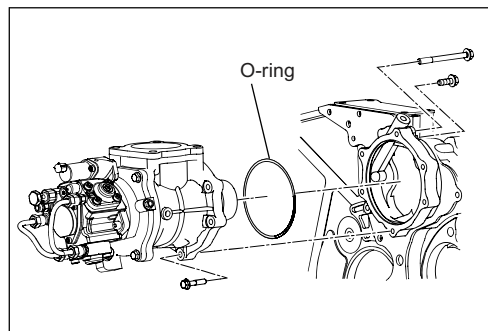

SAPH300020500015

- (4) Replace the O-ring with a new one. Install the supply pump drive assembled with the supply pump on the flywheel housing.

Tightening torque : 28.5 N · m {290 kgf · cm, 21 lbf · ft}

CAUTION • Adjust the gear so that the compression top dead center alignment of the No.1 cylinder may not be changed.

- Be sure to remove the guide bolt in cranking the engine.
- After assembly, be sure to remove the guide bolt and install the inspection window plug.

5. Update of supply pump learning value

- (1) When the supply pump is replaced, update the learning value memorized in the engine ECU with the failure diagnosis tool (HINO field support system) using PC. (Refer to "Hino field support system operation manual".)

CAUTION • If learning value is not updated, correct common rail pressure is not controlled, resulting in engine stall or high common rail pressure. Therefore, when the supply pump is replaced, be sure to update the learning value.

Inspection of supply pump

JP30002050704004

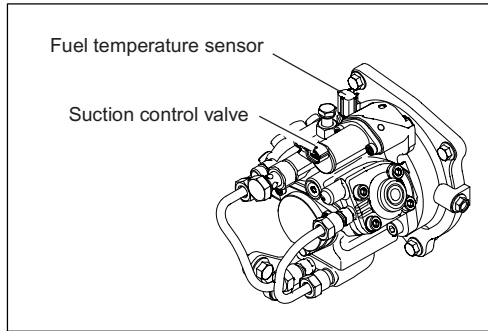

SAPH300020500016

1. Inspection of suction control valve and fuel temperature sensor

- (1) Measure the resistance of the suction control valve terminals and the fuel temperature sensor terminals using a circuit tester. If it is beyond the standard, remove the supply pump assembly and request for replacement at the Denso service shop.

	Between suction control valve terminals
Standard value	7.65 - 8.15Ω(at 20° C {68° F})

	Terminals between fuel temperature sensors
Standard value	13.5 - 16.5kΩ(at -20° C{68° F})
	2.2 - 2.7kΩ(at 20° C{68° F})
	0.29 - 0.35kΩ(at 80° C{176° F})

Replacement of injector

JP30002050704005

1. Removal of injector

- (1) Remove the fixing bolt and remove the plate and the injection pipe oil seal.
- (2) Remove the nozzle clamp holder and remove the injector.

2. Installation of injector

- (1) Attach a new O-ring to the groove of the cylinder head and insert the injector.

⚠ CAUTION • Apply engine oil to the O-ring and be careful to prevent pinching of the O-ring.

- (2) Install the nozzle clamp holder and tack weld the injector temporarily.

⚠ CAUTION • Do not fix the nozzle holder until the injection pipe is tack welded.

- (3) Put a new injection pipe oil seal on the injector and install the plate.

⚠ CAUTION • Install the injection pipe oil seal to prevent undue force to the injection nozzle. (Offset position between the injection pipe oil seal and the injection nozzle may cause oil leak or poor assembly of the injection pipe.)

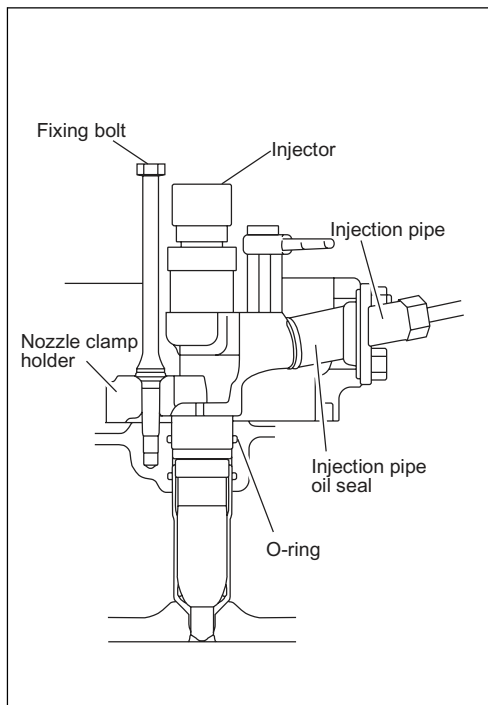

SAPH300020500017

- (4) Assemble the injection pipe temporarily and tighten the fixing bolt of the nozzle clamp holder.

Tightening torque : 25 N · m {250 kgf · cm, 1.8 lbf · ft}

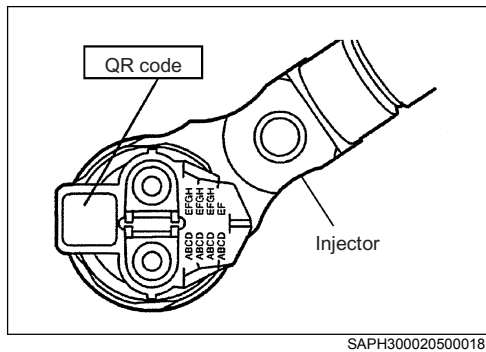

3. Entry of injector correction value to the engine ECU (entry using Hino field support system and QR code reader)

CAUTION • When the injector is replaced, it is necessary to enter the injector correction value (QR code) described on the new injector to the engine ECU. Incorrect entry of the correction value may result in faulty engine.

NOTICE

- Available entry methods of the injector correction value are the PC tool and the QR code reader.
- The work flow is described below. For detailed procedures, refer to the operation manual of the Hino field support system.

- (1) Read the injector QR code with the scanner of the QR code reader and prepare the correction data file.
- (2) Enter the injector correction value directly from the Hino field support system to the engine ECU.

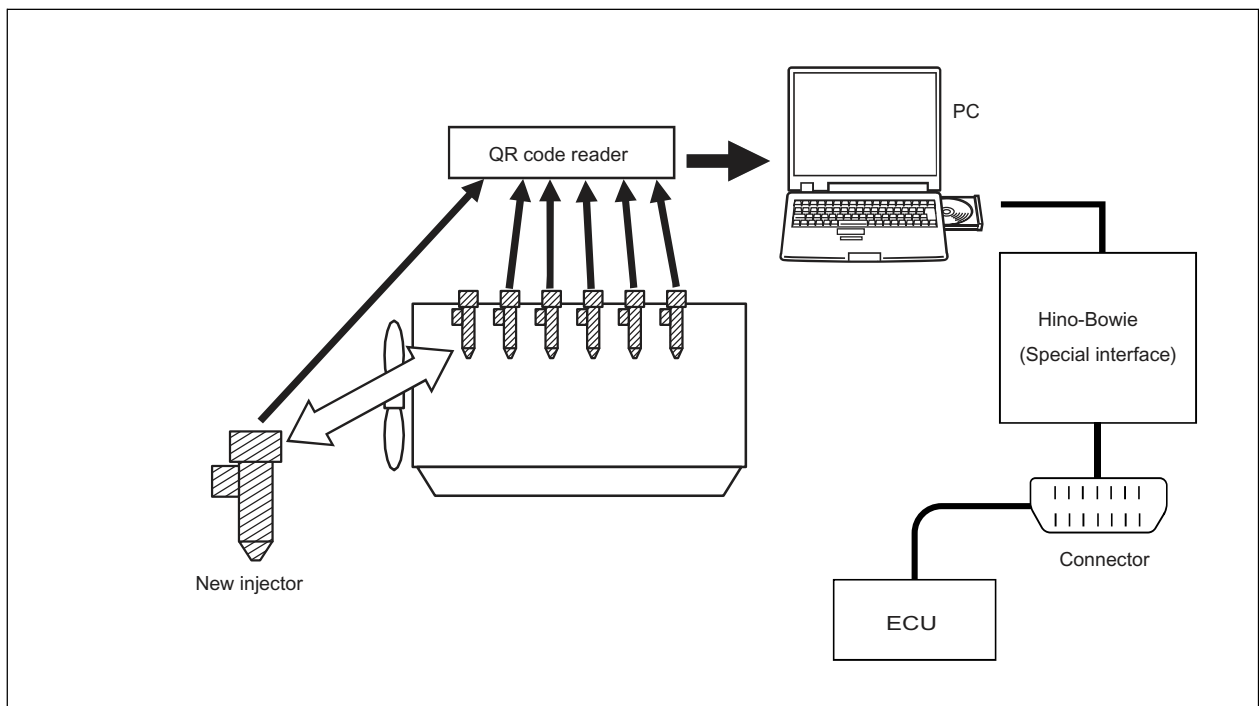

Inspection of injector

JP30002050704006

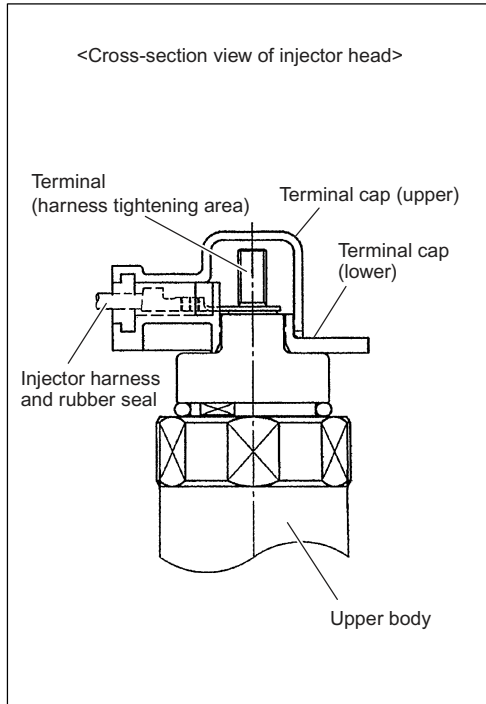

1. Inspection of injector insulation

- (1) Remove the injector plastic terminal cap (upper).
- (2) Measure the insulation resistance between the injector upper body and one terminal (no polarity) of two terminals for the injector harness.

Standard value (normal temperature)	1000MΩ or more
--	-----------------------

- (3) Measure the resistance value between two terminals above.

Standard value (at 20° C)	0.45Ω±0.1
----------------------------------	------------------

- (4) If the resistance value in (2) and (3) exceeds the standard value, replace the injector assembly.

2. Cleaning of injector

- (1) Remove sludge at or around the terminal, if any.

⚠ CAUTION • In removing sludge, do not use a cleaning agent. Wipe it off with a rag. Use of a cleaning agent may result in electric failure due to penetration of the agent.

Replacement of common rail

JP30002050704007

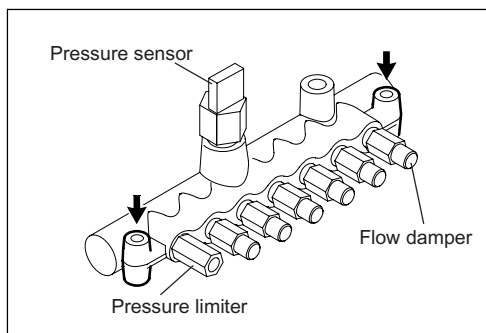

1. Removal of common rail

- (1) Remove the common rail together with the flow damper, pressure sensor and pressure limiter from the intake manifold.

⚠ CAUTION • Remove dirt around parts before removing the common rail

2. Installation of common rail

- (1) Install the common rail on the intake manifold.

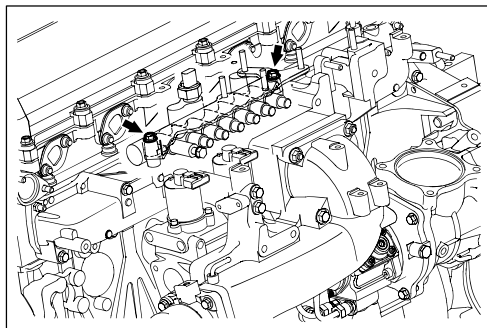

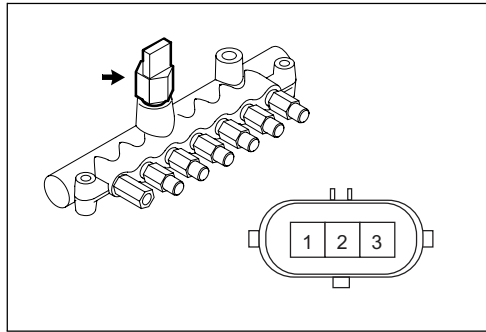

SAPH300020500023

Inspection of common rail

JP30002050704008

1. Inspection of common rail pressure sensor

- (1) Measure the resistance value between terminals using a circuit tester. If it exceeds the standard value, replace the common rail assembly

	Between 1 and 2	Between 2 and 3
Standard value (kΩ) At stop of engine	0.5 - 3.0	6.5 - 18.5

6 EMISSION CONTROL

EGR.....	6-2
Part layout.....	6-2
Overhaul of EGR valve and EGR cooler.....	6-3

EGR

Part layout

JP30002060402001

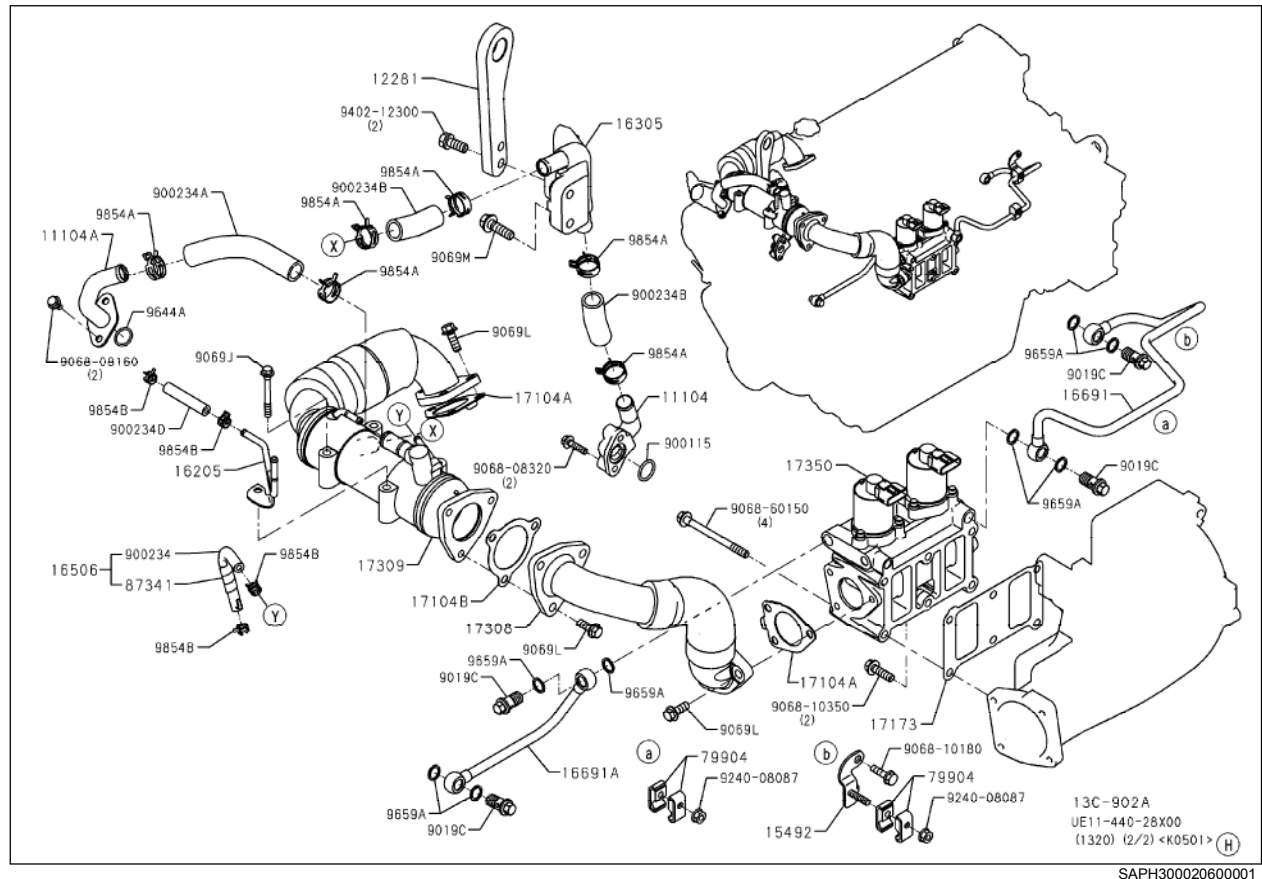

11104	Coolant pipe	17173	Gasket*
11104A	Coolant pipe	17308	EGR pipe
16305	Coolant pipe	17309	EGR cooler assembly
16691	Coolant pipe	17350	EGR valve
16691A	Coolant pipe	900234A	Coolant hose
17104A	Gasket*	900234B	Coolant hose
17104B	Gasket*	9659A	Gasket*

*Parts not to be reused.

Tightening torque

9068-10350	68.5 N·m {700 kgf·cm, 51lb·ft}	9069L	68.5 N·m {700 kgf·cm, 51lb·ft} (Exhaust manifold)
9068-60150	68.5 N·m {700 kgf·cm, 51lb·ft}	9069L	68.5 N·m {700 kgf·cm, 51lb·ft} (EGR valve – EGR pipe) (EGR cooler – EGR pipe)
9069J	37 N·m {377 kgf·cm, 27lb·ft}		

Overhaul of EGR valve and EGR cooler

JP30002060704001

1. Removal of EGR valve

⚠ CAUTION • Since burn may occur, replace the part after cooling. (Leave it standing for 30 minutes or more after the starter key is turned OFF.)

- (1) Remove the connector from the EGR solenoid valve.
- (2) Remove the EGR pipe.
- (3) Remove the coolant pipe (inlet pipe and outlet pipe) connected to the EGR valve.

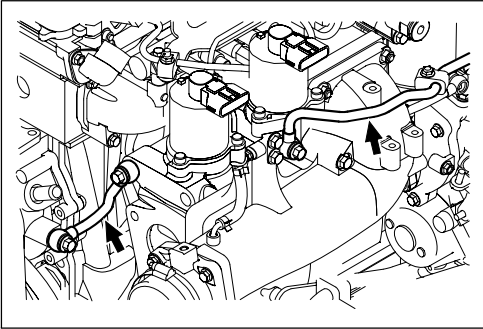

SAPH300020600002

- (4) Remove 6 bolts and 2 nuts and remove the intake air pipe together with the EGR valve.

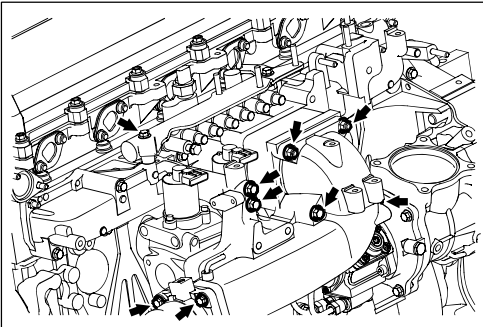

SAPH300020600003

- (5) Fix the intake air pipe with a vice and remove 6 bolts to remove the EGR valve.

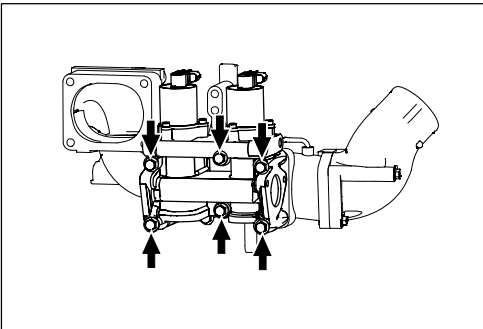

SAPH300020600004

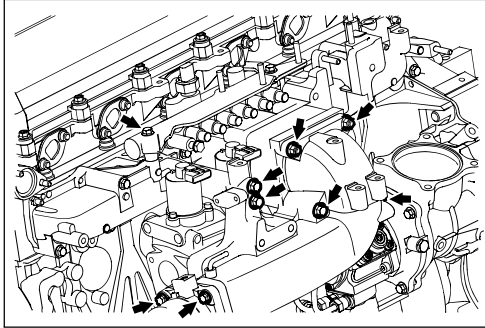

SAPH300020600003

2. Installation of EGR valve

- (1) Replace the EGR valve gasket with a new one and install the EGR valve on the intake air pipe paying attention to the direction

Tightening torque : 68.5 N · m {700 kgf · cm, 51 lbf · ft}

- (2) Apply liquid gasket (Threebod TB1207B: Black) to the intake air pipe and connect it to the intake manifold.

Tightening torque : 55 N · m {560 kgf · cm, 41 lbf · ft}

- (3) Connect each coolant pipe to the EGR valve.
- (4) Connect the EGR pipe.

Tightening torque :

57±11 N · m {582±116 kgf · cm, 42±8 lbf · ft}

- (5) Connect the connector to the EGR solenoid valve.

3. Removal of EGR cooler

- (1) Remove hoses and pipes from the EGR cooler.

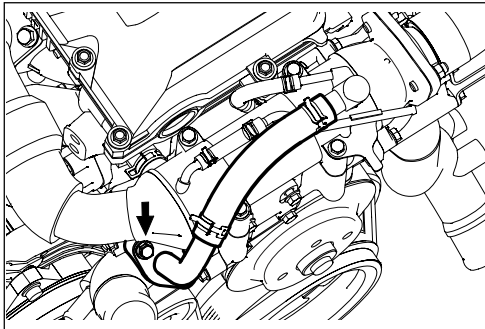

SAPH300020600005

- (2) Loosen bolts connecting the EGR cooler and the EGR pipe.

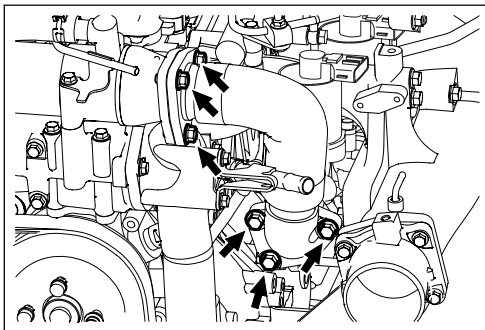

SAPH300020600006

- (3) Remove the EGR pipe.

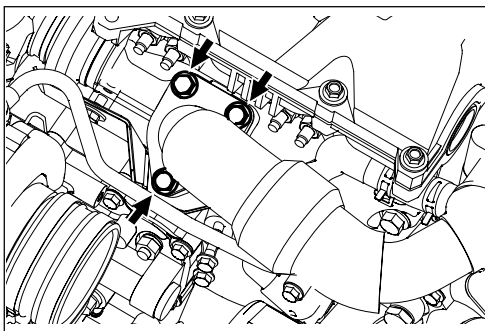

SAPH300020600007

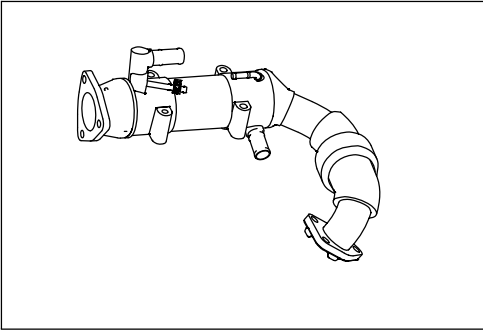

SAPH300020600008

- (4) Remove the EGR cooler.

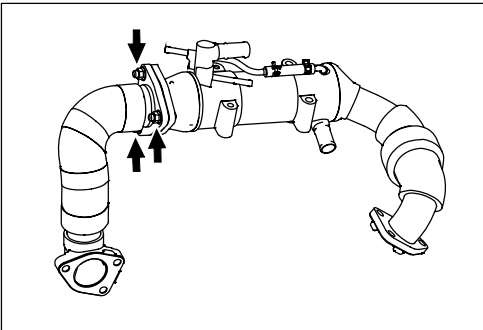

SAPH300020600009

4. Installation of EGR cooler

- (1) Replace the gasket with a new one and tighten the EGR pipe and the EGR cooler temporarily.

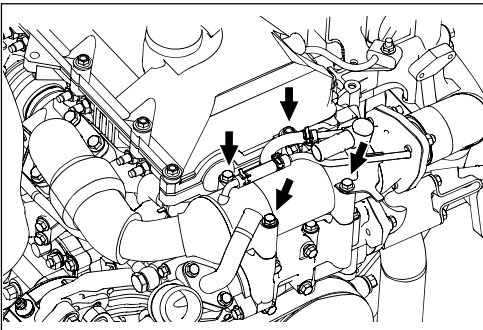

SAPH300020600010

- (2) Install the EGR cooler.

Tightening torque : 37 N · m {377 kgf · cm, 27 lbf · ft}

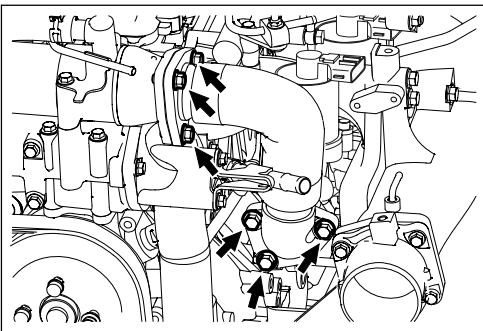

SAPH300020600006

- (3) Tighten the EGR pipe and the EGR cooler with bolts.

Tightening torque :

57±11 N · m {582±116 kgf · cm, 42±8 lbf · ft}

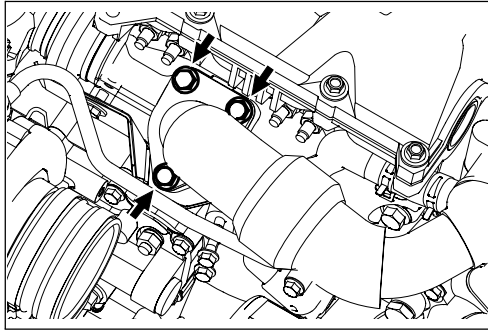

SAPH300020600011

- (4) Connect the EGR pipe.
Tightening torque : 68.5 N · m {700 kgf · cm, 51 lbf · ft}
- (5) Connect hoses and pipes to the EGR cooler.

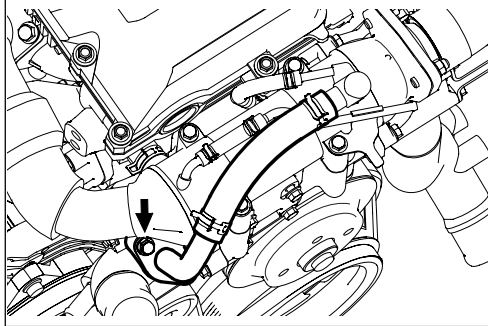

SAPH300020600012

5. Inspection of EGR cooler

- (1) Check visually for crack or clogging of the unit gas channel and the sub-coolant pipe.
If a faulty item is found, replace the EGR cooler unit.

6. Inspection of EGR (Inspection with Hino-DX)

- (1) Inspect operation of the EGR valve on the vehicle using Hino-DX. (Refer to the “Hino field support system operation manual”.)

7 ELECTRICAL

Electrical System.....	7-2
Part layout.....	7-2
Layout of components.....	7-4
Inspection of components.....	7-6
Installation of component.....	7-8
Installation of starter.....	7-8
Removal of alternator.....	7-9
Installation of alternator.....	7-10

Electrical System

Part layout

JP30002070402001

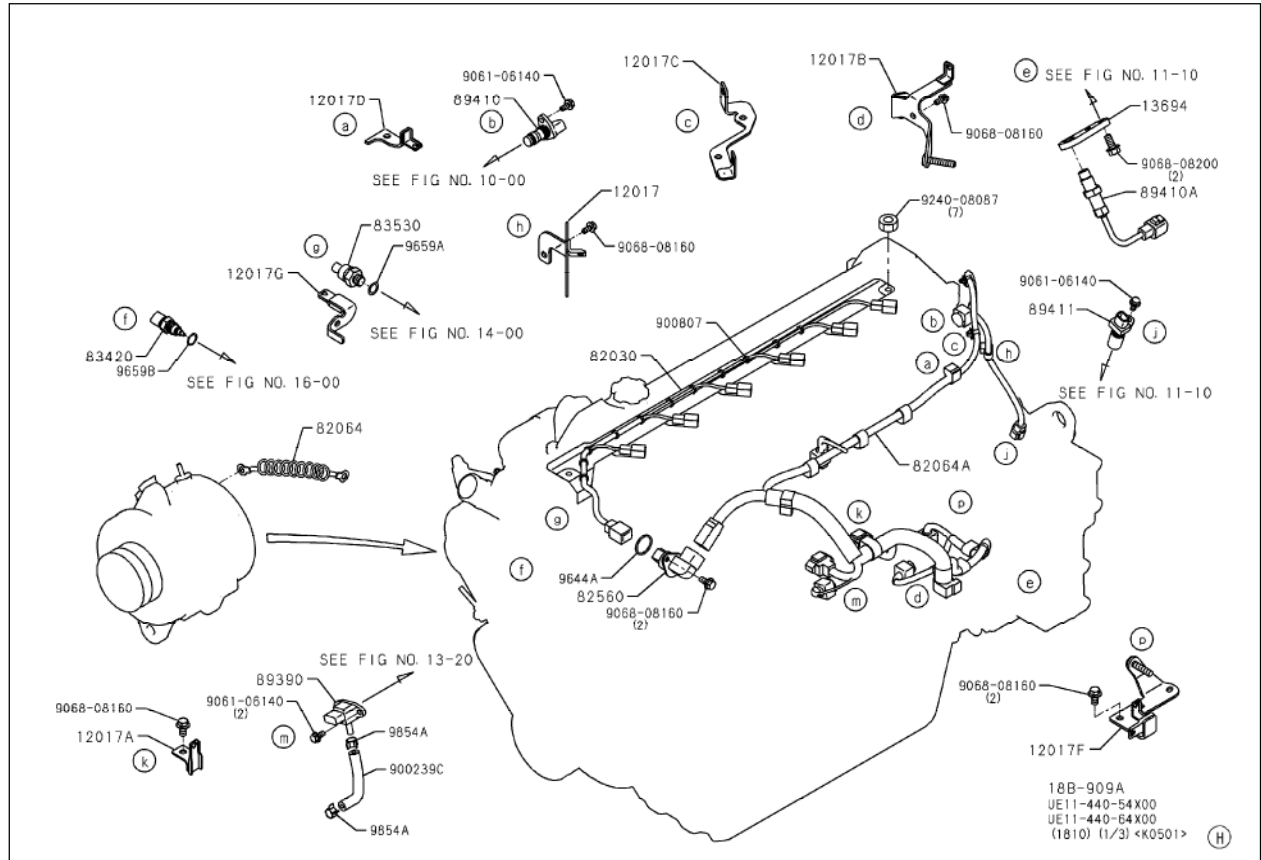

SAPH300020700001

82030	Injector harness	89390	Boost pressure sensor
83420	Water temperature sender gauge	89410	Engine sub-revolution sensor
83530	Oil pressure warning switch	89411	Engine main revolution sensor

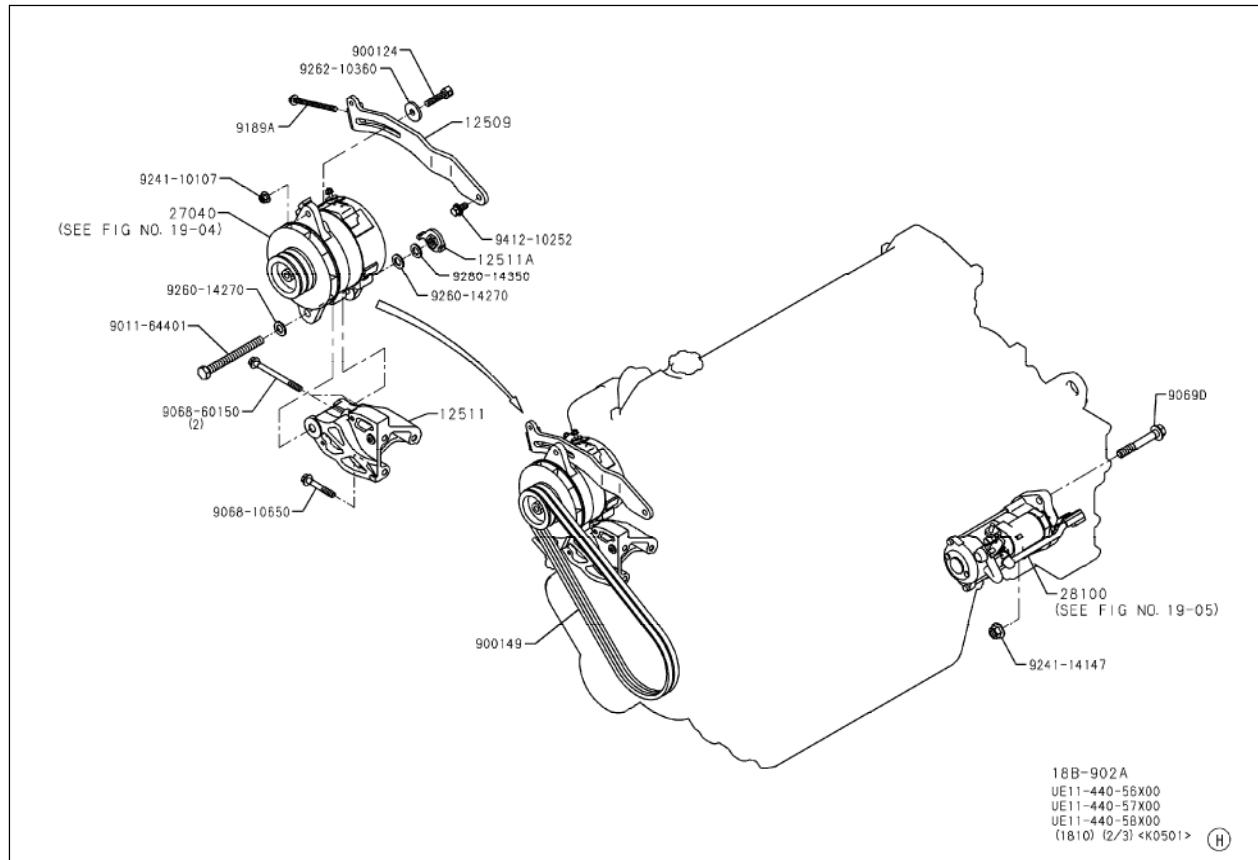

SAPH300020700002

12511	Alternator bracket	28100	Starter assembly
27040	Alternator	900145	V -belt

Tightening torque

9011-64401	83 N·m {850 kgf·cm, 61 lbf·ft}	9241-10107	51 N·m {520 kgf·cm, 37 lbf·ft}
9069D	154 N·m {1,570 kgf·cm, 114 lbf·ft}	9241-14147	154 N·m {1,570 kgf·cm, 114 lbf·ft}

Layout of components

JP30002070402002

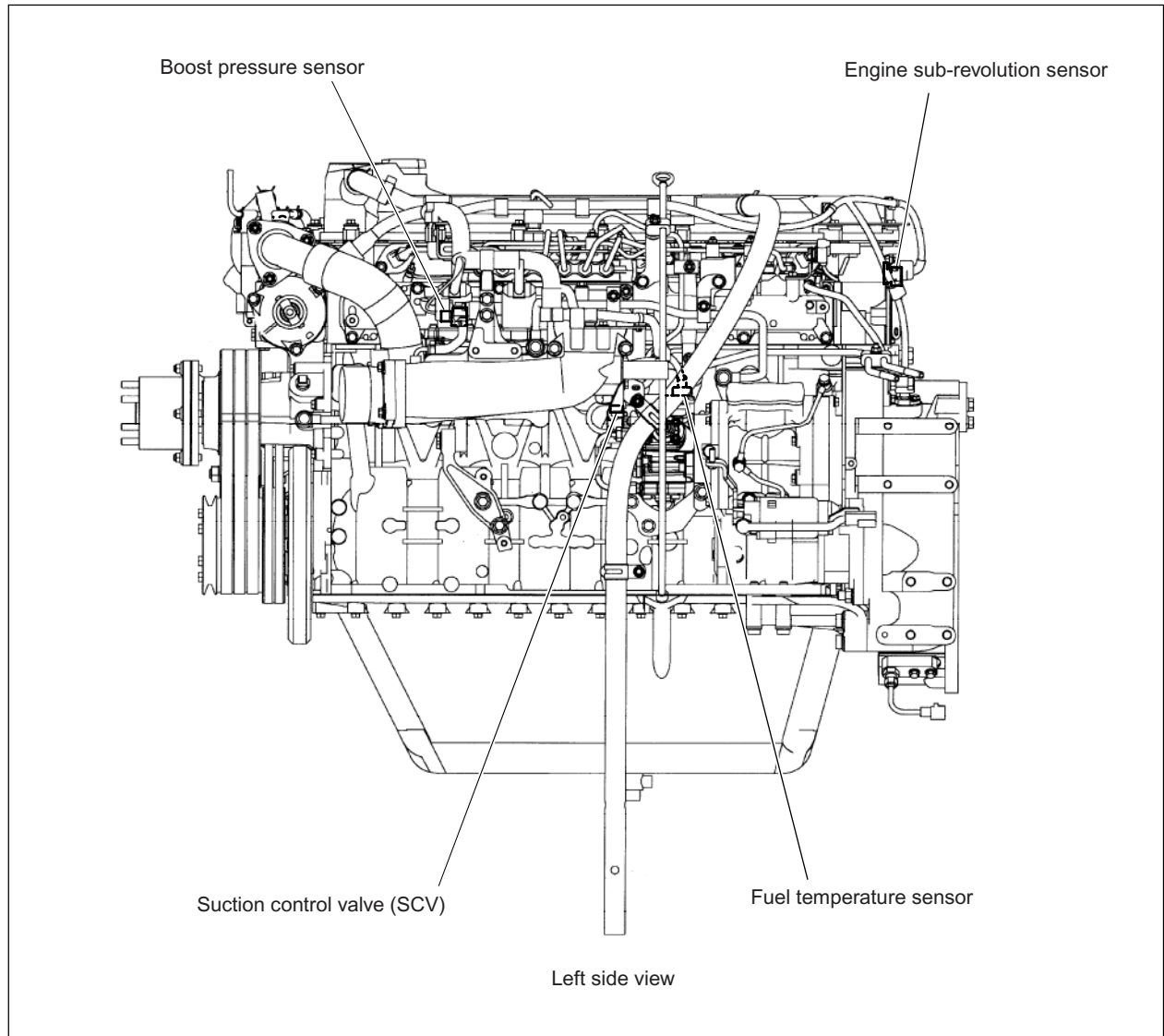

SAPH300020700003

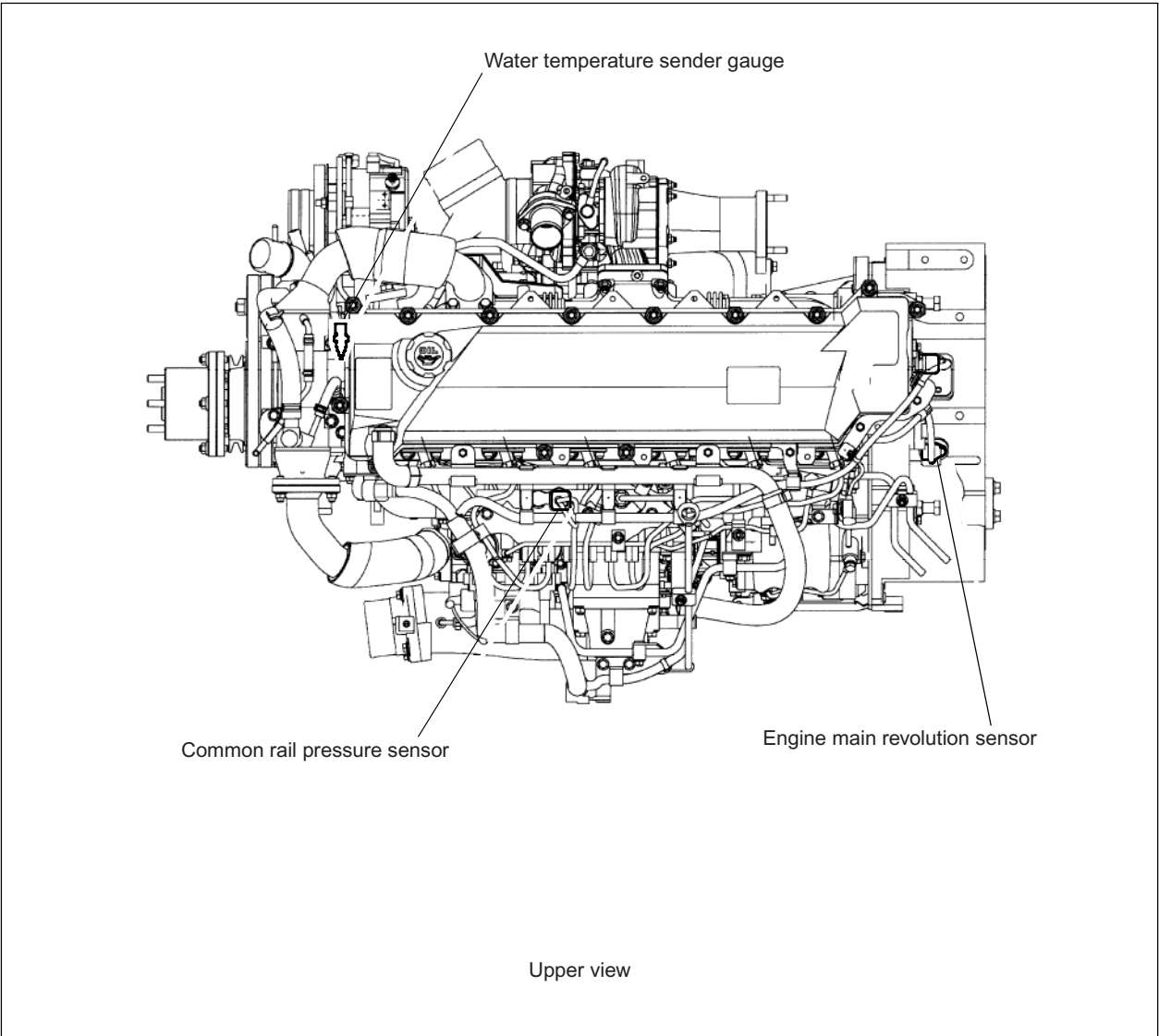

Inspection of components

JP30002070702001

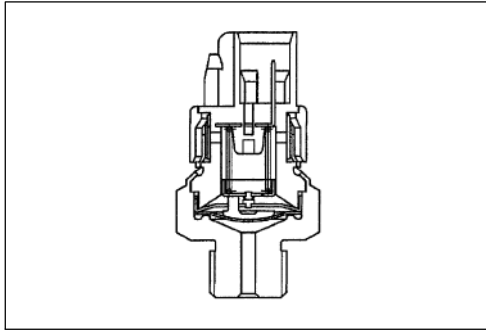

SAPH300020700005

1. Inspection of oil pressure warning switch (Laid out on the oil filter)

- Apply pressure with air or oil and check continuity between terminals using a circuit tester. If it is faulty, replace it.

At no load or less than 39 kPa {0.4 kgf/cm ² , 5.6565 lbf/in. ² }	With continuity
At 39 kPa {0.4 kgf/cm ² , 5.6565 lbf/in. ² } or more	Without continuity

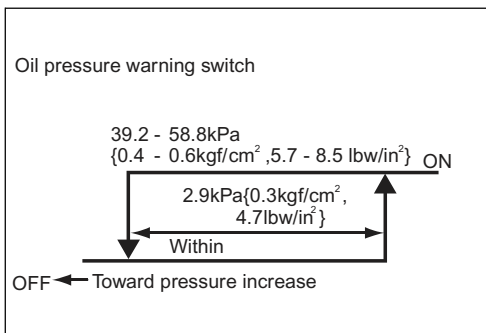

SAPH300020700006

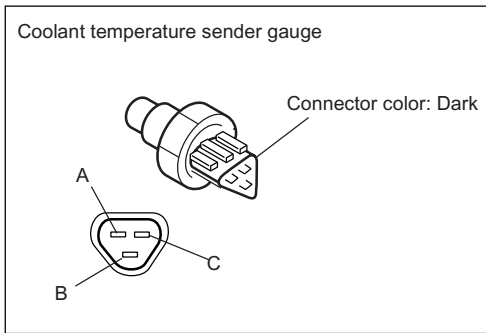

SAPH300020700007

2. Inspection of coolant temperature sender gauge (Installation on thermostat case)

- Heat the coolant temperature sender gauge using hot water.
- Measure the resistance between terminals using a circuit tester. If it is faulty, replace the gauge.

Between A and C

Temperature (°C {°F})	-20 {-68}	20 {68}	80 {176}	110 {230}
Resistance value (Ω)	13.84 - 16.33	2.32 - 2.59	0.31 - 0.326	0.1399 - 0.1435

Between B and body

Temperature (°C, °F)	75 {167}	100 {212}
Resistance value (Ω)	79 - 92	35.5 - 42.5

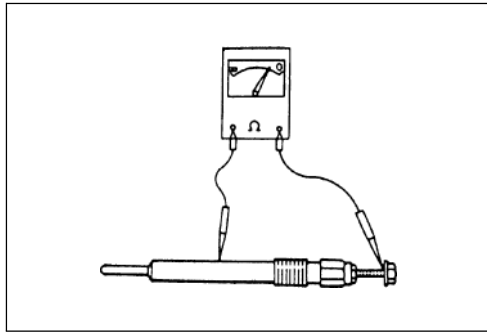

SAPH300020700008

3. Inspection of glow plug

- (1) Measure continuity between the body and the terminal using a circuit tester. If it is faulty, replace the glow plug.

Standard value	
Resistance value : Ω (Normal temperature 20°C{68°F})	2.59 - 3.29

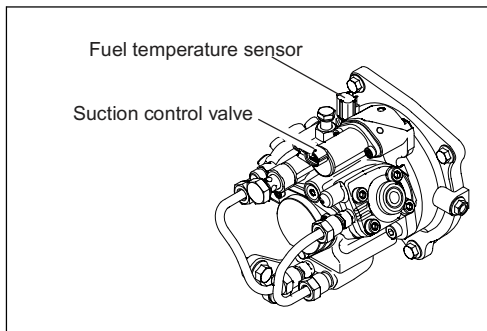

SAPH300020700009

4. Inspection of suction control valve SCV and fuel temperature sensor

- (1) For inspection and replacement of the suction control valve (SCV) and the fuel temperature sensor, refer to the chapter of "J08E Fuel".

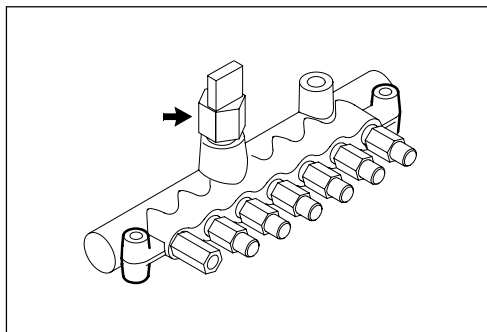

SAPH300020700010

5. Inspection of common rail pressure sensor

- (1) For inspection and replacement of the common rail pressure sensor, refer to the chapter of "J08EFuel".

6. Inspection of injector

- (1) For inspection and replacement of the injector, refer to the chapter of "J08EFuel".

Installation of component

JP30002070702002

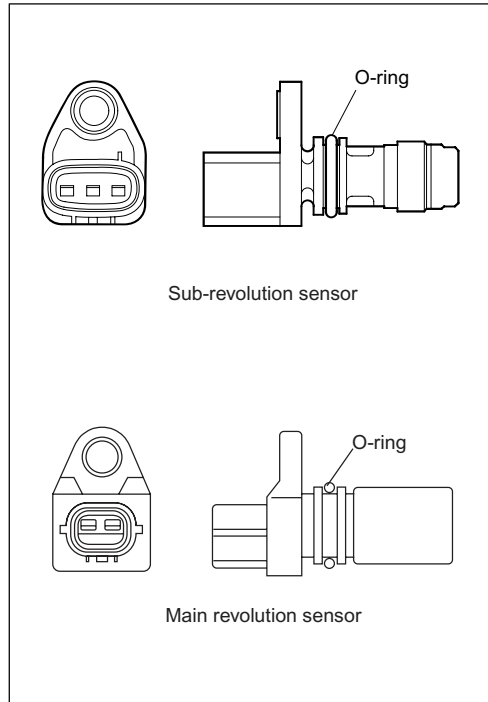

SAPH300020700011

1. Installation of engine revolution sensor

- (1) Make sure that the sensor has the O-ring. Install the sensor on the flywheel housing and the cam housing.

NOTICE

- Since this sensor is a flange type, gap does not have to be adjusted.

Installation of starter

JP30002070702003

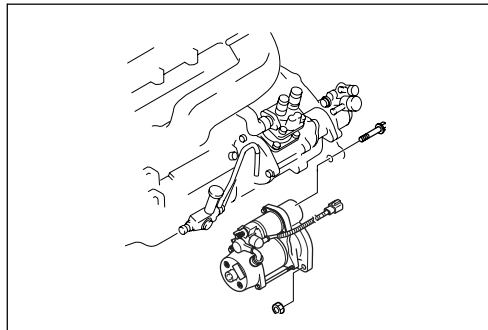

SAPH300020700012

1. Install the starter with bolts and nuts.

Tightening torque : 154 N · m {1,570 kgf · cm, 114 lbf · ft}

Removal of alternator

JP300020702004

1. Remove the through bolt.

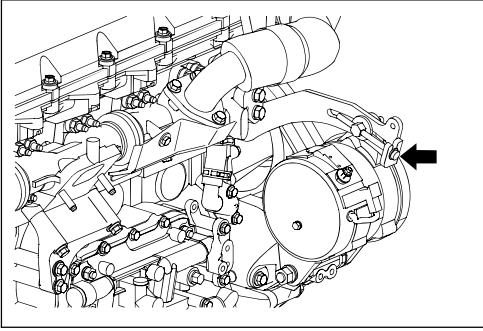

SAPH300020700013

2. Remove the alternator adjusting bolt.

3. Remove the through bolt while supporting the alternator, and remove the alternator.

⚠ CAUTION • When the through bolt is removed, the alternator falls. The alternator must be firmly supported during removal.

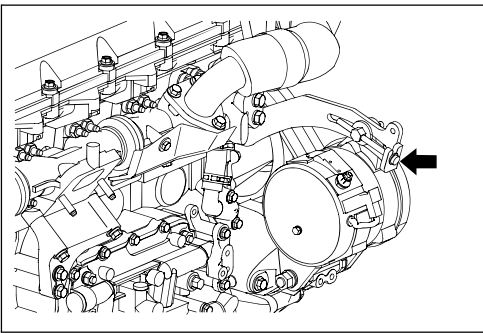

SAPH300020700013

Installation of alternator

JP300020702005

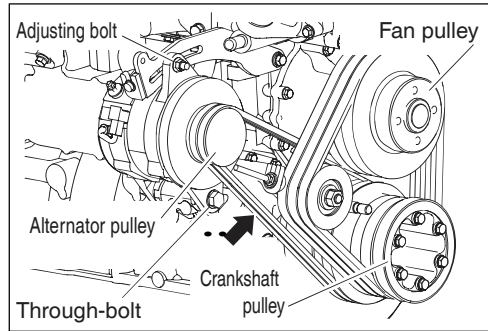

SAPH300020

1. Installation of alternator

- (1) Tighten the alternator temporarily using through bolts and nuts.
- (2) Tighten the adjusting bolt temporarily.

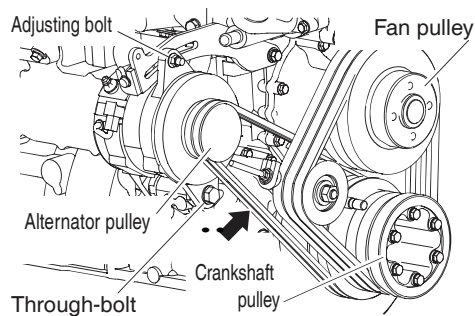

SAPH300020700014

2. V-belt tension adjustment

- (1) Place a tire lever on the alternator and adjust the V-belt (Measuring position: A) within the standard value using a special tool. Tighten adjusting bolts and through bolts.

**Special tool : 380100042 Compression gauge
380100043 Belt tension gauge**

⚠ CAUTION • When a tire lever is placed, do not place it beyond the shaded area shown in the alternator figure.

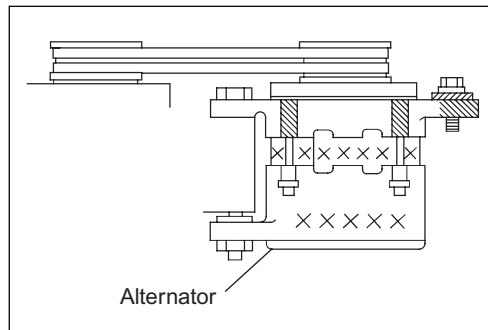

SAPH300020700015

Deflection: 380100042 is used.

Standard value (mm{in.}) [Reference pressing force 98 N {10 kgf, 22lbf}]	8 - 10{0.3152 - 0.394}
--	------------------------

Tension: 380100043 is used.

Standard value (N {kgf, lbf})	340 - 440{35 - 45, 76 - 99}
----------------------------------	-----------------------------

Tightening torque : Through bolt
83 N · m {850 kgf · cm, 61 lbf · ft}

Tightening torque : Adjusting bolt
51 N · m {520 kgf · cm, 38 lbf · ft}

8 INTAKE

Intake Manifold	8-2
Part layout.....	8-2
Replacement.....	8-3

Intake Manifold

Part layout

JP30002080402001

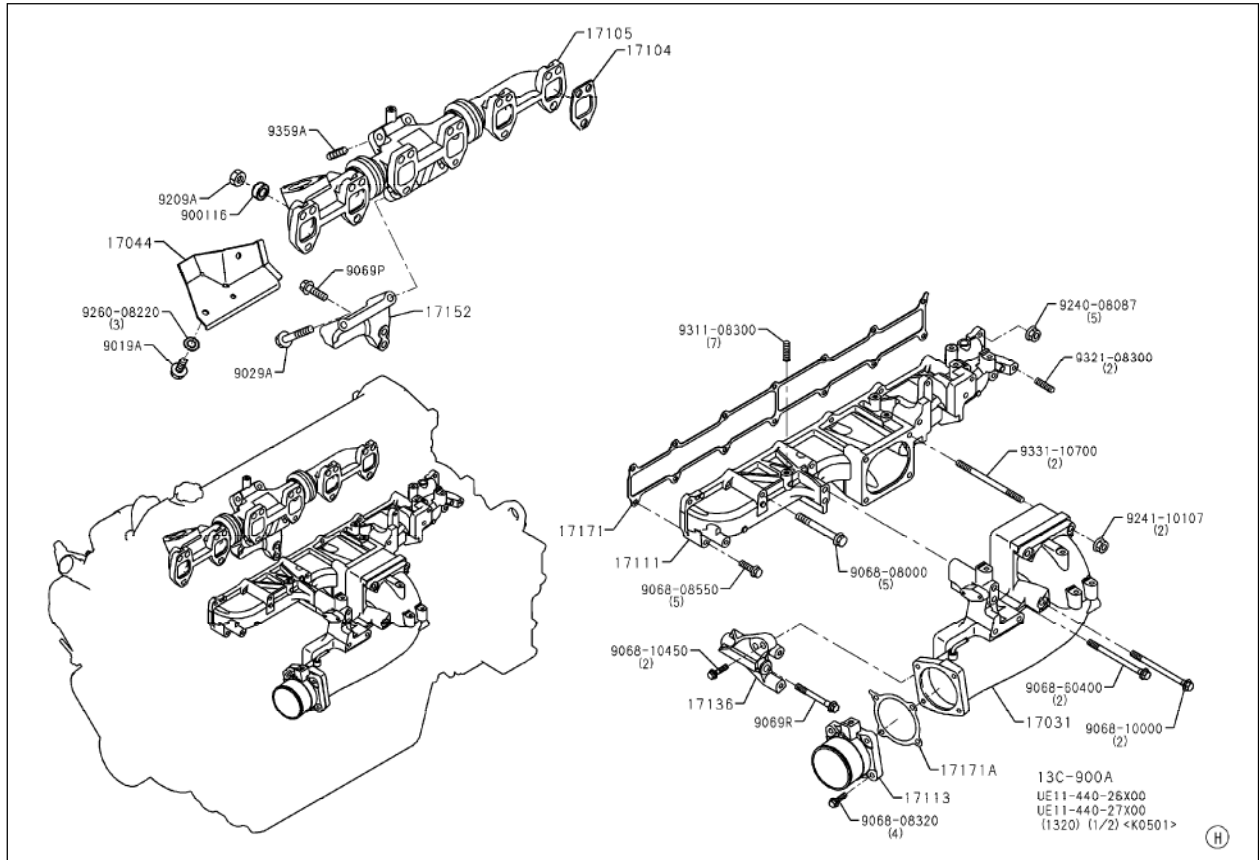

SAPH300020800001

17031	Intake pipe	17113	Intake pipe
17111	Intake manifold	17171	Gasket*

*Parts not to be reused.

Tightening torque

9068-08000	28.5 N·m {290 kgf·cm, 21lb·ft}	9240-08087	28 N·m {290 kgf·cm, 21lb·ft}
9068-08550	28.5 N·m {290 kgf·cm, 21lb·ft}		

Replacement

JP30002080704001

1. Removal of intake manifold

- (1) Remove bolts and nuts and remove the intake manifold.

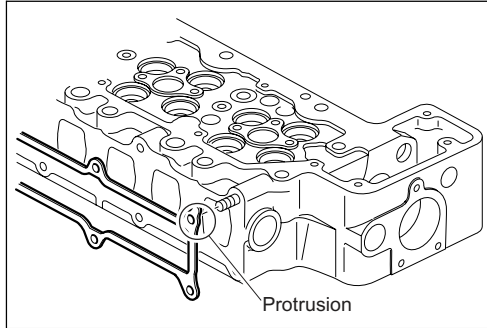

SAPH300020800002

2. Installation of intake manifold

- (1) Clean inside of the intake manifold and the cylinder head.
- (2) Assemble a new gasket.

⚠ CAUTION • Install the gasket so that the protrusion may come at the rear end stud bolt of the cylinder head.

- (3) Install the intake manifold and tighten it with bolts and nuts.

Tightening torque : 28.5 N·m {290 kgf·cm, 21 lbf·ft}

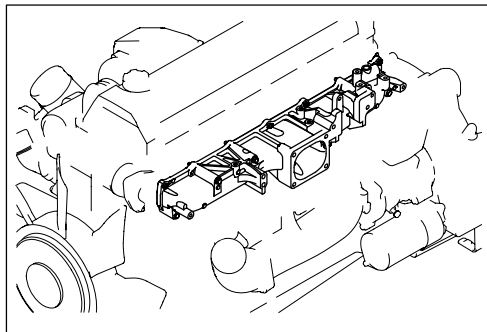

SAPH300020800003

3. Installation of intake pipe

- (1) After removing contamination on the contact surface, apply liquid gasket [Threebond TB1207B(black) or equivalent] to the circumference of the contact surface.

⚠ CAUTION • Apply it continuously.
 • Apply the liquid gasket at the width of 1.5 to 2.5 mm {0.0591 to 0.09843 in.}
 • Install the oil cooler within 20 minutes after application of the liquid gasket.

- (2) Install the intake pipe with bolts and nuts.

9 ENGINE MECHANICAL

Cylinder Head	9-2
Part layout.....	9-2
Replacement of cylinder head	9-4
Replacement of camshaft housing	9-6
Liquid gasket application procedure for cylinder plug (only when cylinder plug is removed).....	9-7
Replacement of head cover	9-8
Overhaul of cylinder head	9-9
Cylinder Block	9-12
Part layout.....	9-12
Overhaul	9-13
Timing Gear Cover and Flywheel Housing.....	9-17
Part layout.....	9-17
Replacement of flywheel housing	9-18
Replacement of rear end plate	9-18
Replacement of crankshaft front oil seal.....	9-19
Replacement of crankshaft rear oil seal.....	9-21
Main Moving Parts.....	9-23
Part layout.....	9-23
Replacement of piston and connecting rod	9-24
Inspection of piston and connecting rod	9-28
Replacement of connecting rod bushing.....	9-30
Replacement of crankshaft	9-32
Inspection of crankshaft.....	9-34
Replacement of crankshaft pulley.....	9-37
Replacement of flywheel	9-37
Camshaft and Idle Gear	9-40
Part layout.....	9-40
Removal of camshaft	9-40
Disassembly of camshaft.....	9-41
Inspection of camshaft and camshaft bearing	9-41
Assembly of camshaft.....	9-42
Installation of camshaft	9-43
Gear train layout	9-44
Removal of timing gear	9-44
Inspection of timing gear components	9-45
Installation of timing gear	9-46
Overhaul of sub-idle gear (bearing case side)	9-48
Inspection of installation status for each gear	9-50
Valve System.....	9-54
Part layout.....	9-54
Overhaul of valve system.....	9-55
Adjustment of valve clearance	9-60

Cylinder Head

Part layout

JP30002090402001

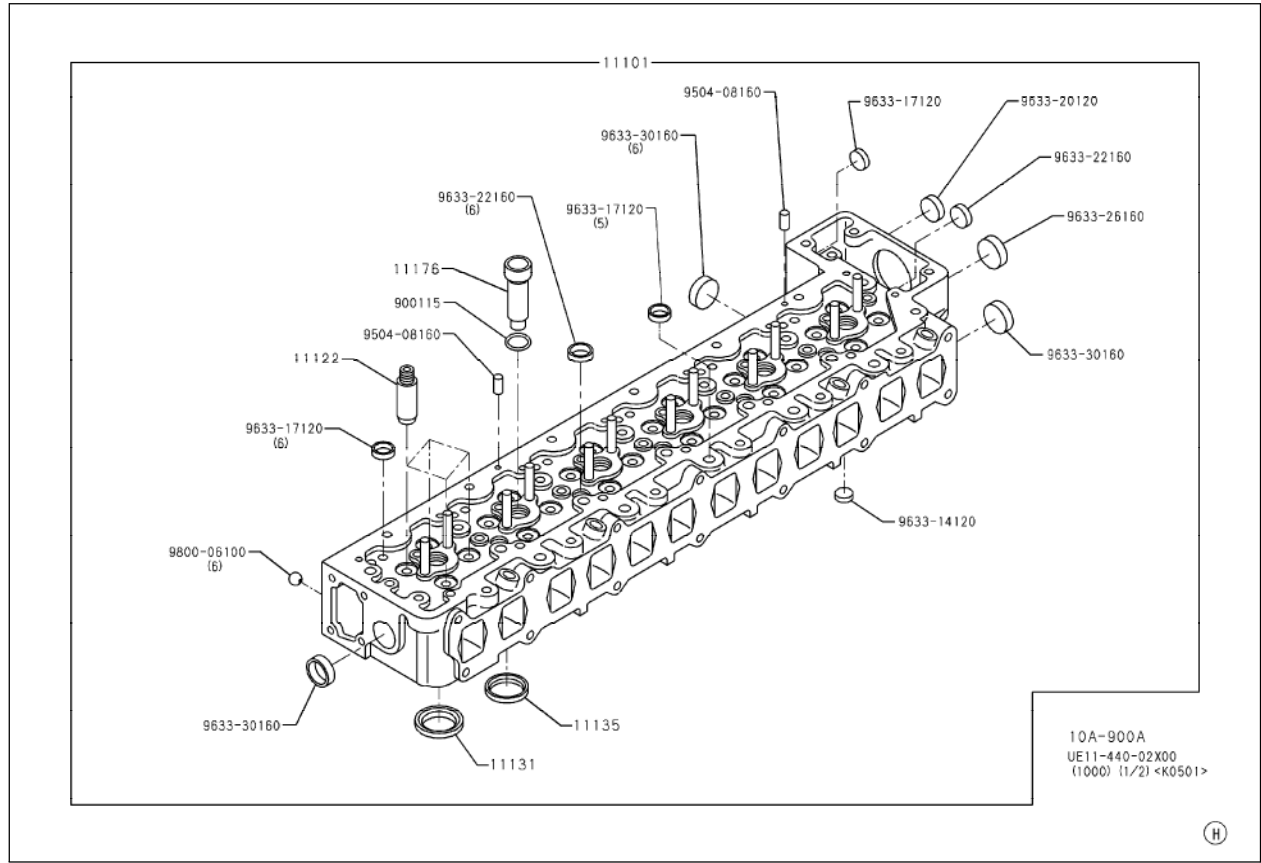

SAPH300020900001

11101	Cylinder head assembly	11135	Exhaust valve seat
11122	Valve guide	11176	Nozzle seat
11131	Intake valve seat	900115	Gasket*

*Parts not to be reused.

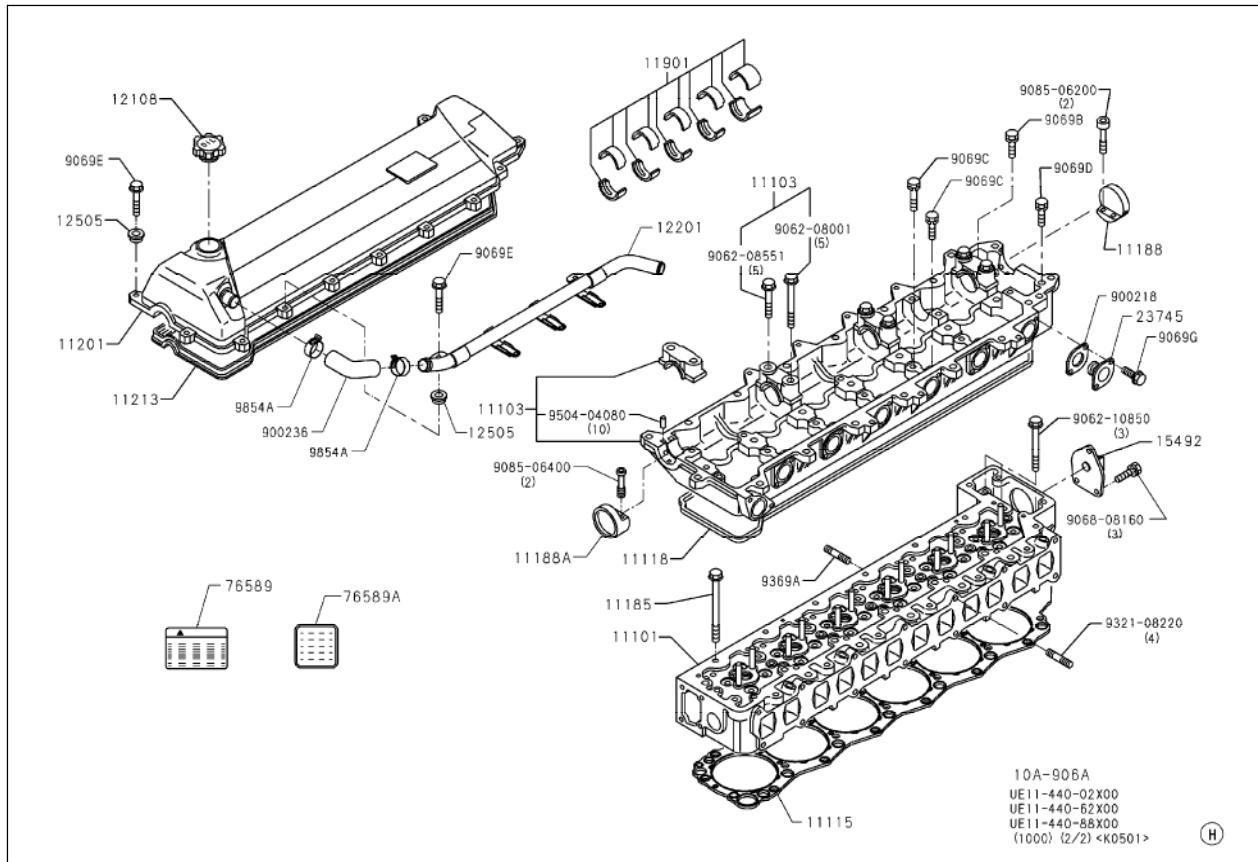

SAPH300020900002

11101	Cylinder head assembly	11188A	Cylinder plug
11103	Camshaft housing	11201	Cylinder head cover
11115	Cylinder head gasket	11213	Head cover gasket
11118	Camshaft housing gasket	12108	Oil filler cap
11188	Cylinder plug	23745	Pipe oil seal

*Parts not to be reused.

Tightening torque

11185	59N·m{600kgf·cm, 44lbf·ft}+90°+90°	9069E	28.5N·m{290kgf·cm, 21lbf·ft}
9062-10850	59N·m{600kgf·cm, 44lbf·ft}	9062-08001	31N·m{320kgf·cm, 23lbf·ft}
9069B	23N·m{230kgf·cm, 17lbf·ft}	9062-08551	31N·m{320kgf·cm, 23lbf·ft}
9069C	23N·m{230kgf·cm, 17lbf·ft}	9085-06200	6N·m{60kgf·cm, 4lbf·ft}
9069D	23N·m{230kgf·cm, 17lbf·ft}	9085-06400	6N·m{60kgf·cm, 4lbf·ft}

Replacement of cylinder head

JP30002090704001

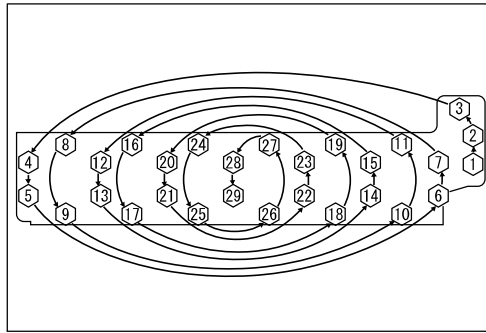

SAPH300020900003

1. Removal of cylinder head and head gasket

- (1) Loosen the head bolts from outside to inside gradually (1/4 turn for each) as shown in the order of the figure and remove them.

- (2) Remove the cylinder head using an eye bolt and hoist.

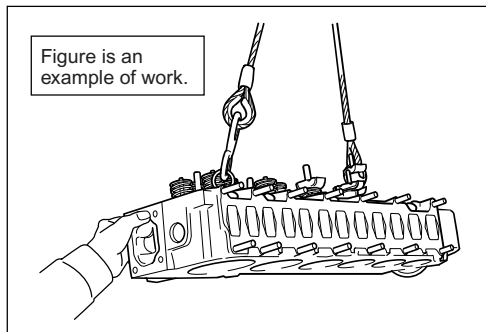

SAPH300020900004

NOTICE

- If it is difficult to remove the cylinder head, insert a chisel between the cylinder head and the cylinder block, and move the chisel vertically so that the contact surface may not be damaged. Then, separate the cylinder head.

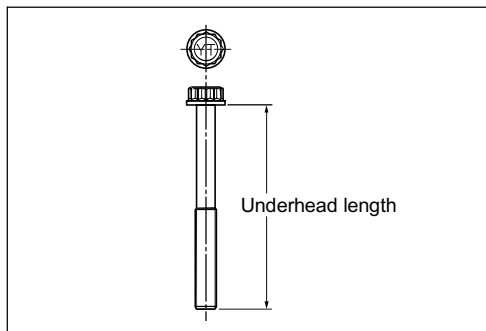

SAPH300020900005

2. Inspection of head bolt length

- (1) Measure the underhead length of the head bolt (M12 only) using vernier calipers. If it is beyond the service limit, replace it with a new one.

Service limit (mm{in.})	126.5{4.9803 in.}
-------------------------	-------------------

3. Installation of head gasket and liquid gasket application procedure

- (1) Cut the rear end plate gasket to be flush with the surface of the cylinder block upper surface using a scraper.
- (2) Install the head gasket on the cylinder block and the flywheel housing.



CAUTION • Remove dirt, water or oil from the mounting surfaces of the cylinder head and the cylinder block before work.

- Never reuse the gasket. Otherwise, it may damage the engine.

- The water hole seal ring of the head gasket is susceptible to damage. Avoid contact with hand or object.

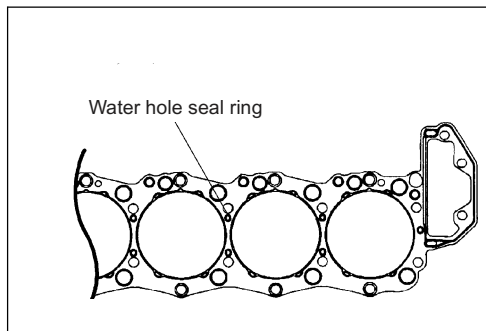

SAPH300020900006

- Before installation of the head gasket, make sure that there is no fall of or damage to the seal ring.

- (3) Apply appropriate amount of liquid gasket [Threebond TB1211 (white) or equivalent] to the head gasket hole at the joint surface between the cylinder block and the flywheel housing.

- CAUTION**
- Apply the liquid gasket so that the surface of the liquid gasket may be raised on the head gasket.
 - Install the oil cooler within 20 minutes after application of the liquid gasket.

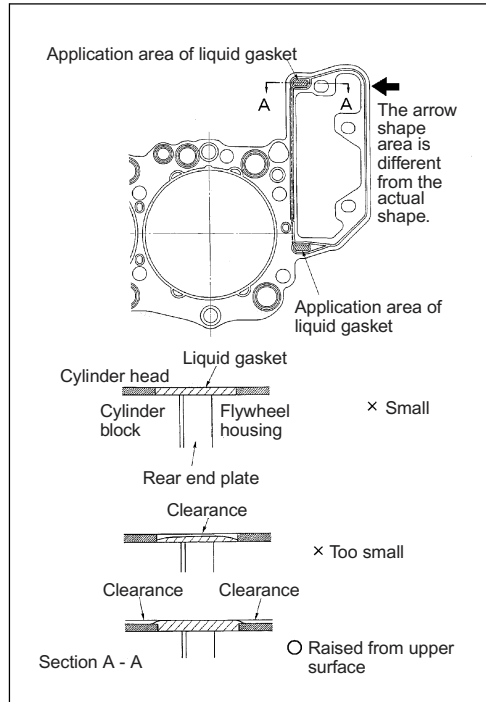

SAPH300020900007

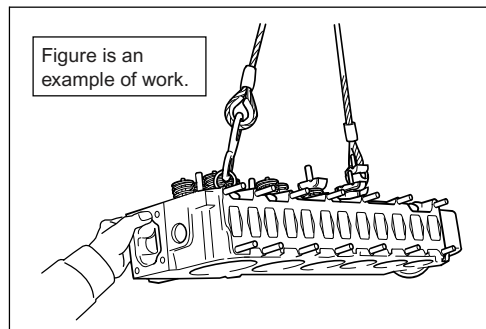

SAPH300020900004

4. Installation of cylinder head

- (1) Clean the head bolt seat at the cylinder head upper surface and the cylinder head lower surface.
- (2) Apply engine oil to the head bolt seat and the bolt thread.
- (3) Align the dowel pins of the cylinder block using a special tool and hoist and mount the cylinder head.

- CAUTION**
- Before mounting the cylinder head, make sure that there is no foreign matter in the cylinder.
 - When the cylinder head is mounted, be careful for engagement between the cam idle gear and the sub-idle gear. (Contact of gear teeth with undue force may cause impact mark or chipping, resulting in abnormal noise or missing tooth.)

- NOTICE**
- Mounting of the cylinder head with guide bolt can prevent displacement of the liquid gasket.

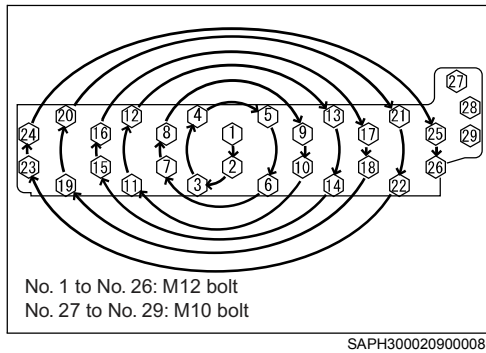

- (4) Tighten head bolts M12 only in the order from the center to outside.

Tightening torque : 59 N·m {600 kgf·cm, 44 lbf·ft}

- (5) After tightening M12 bolt, tighten the bolts again from the center to outside.

Tightening torque : 59 N·m {600 kgf·cm, 44 lbf·ft}

- (6) Mark the heads of the head bolts (M12 only) using paint.
(7) Retighten the 90 deg head bolts (M12 only) in the same order in (5).
(8) Retighten the 90 deg head bolts (M12 only) in the same order.
(9) Make sure that all marks face the same direction.

! CAUTION • If a bolt is turned excessively in retightening, do not loosen it.

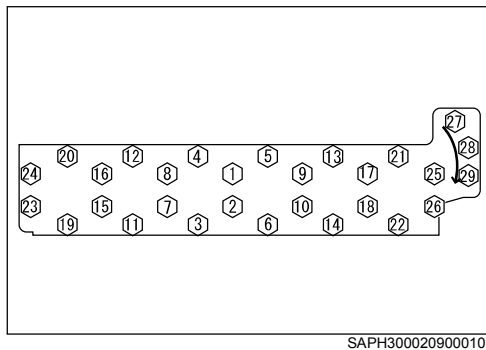
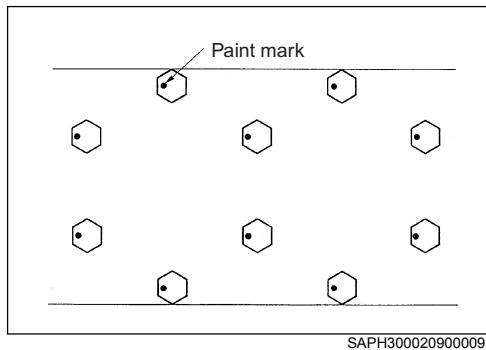

- (10) Tighten remaining head bolts (M10) in the order in the figure.

Tightening torque : 59 N·m {600 kgf·cm, 44 lbf·ft}

Replacement of camshaft housing

JP30002090704002

1. Removal of camshaft housing

- (1) Remove bolts and remove the camshaft housing.

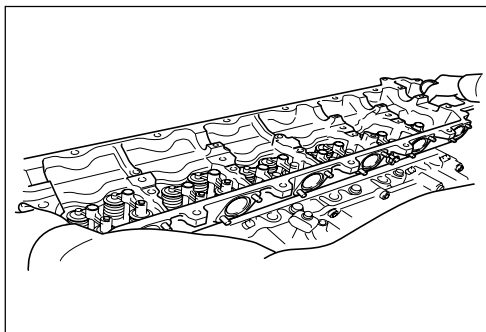

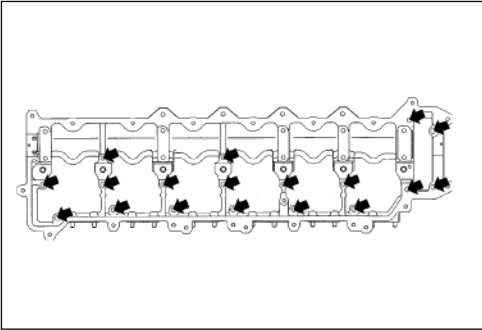

SAPH300020900012

2. Installation of camshaft housing

- (1) Install new gasket and camshaft housing.

Tightening torque : 23 N · m {230 kgf · cm, 17 lbf · ft}

- ⚠ **CAUTION** • Refer to the figure for the mounting bolt position.

Liquid gasket application procedure for cylinder plug (only when cylinder plug is removed)

JP30002090704003

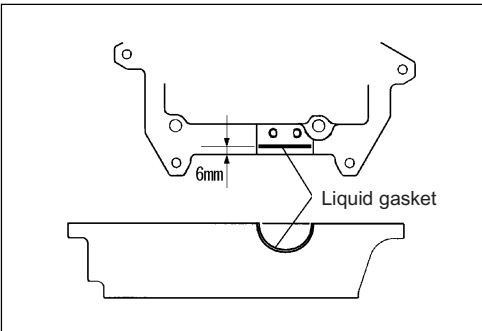

SAPH300020900013

1. Remove liquid gasket from the cylinder plug and the camshaft housing.
2. Apply the liquid gasket [Threebond TB1207B (black) or equivalent] to the semi-circular areas at the front/rear ends of the camshaft housing and install the cylinder plug.

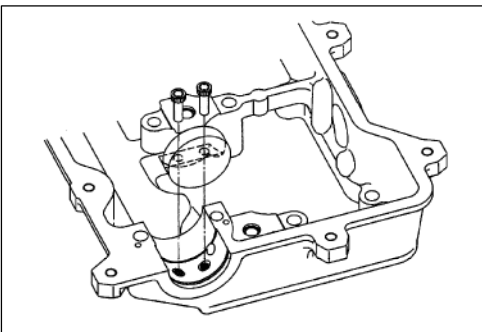

SAPH300020900014

3. Tighten the Torx bolt.

Tightening torque : 6 N · m {60 kgf · cm, 4 lbf · ft}

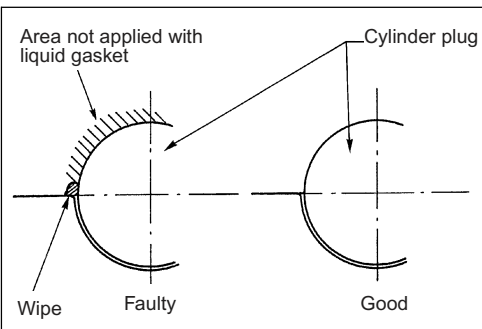

SAPH300020900015

- ⚠ **CAUTION** • Be sure to wipe protruding liquid gasket.
• Make sure that the cylinder plug is seated without inclination to the front or back.

Replacement of head cover

JP30002090704004

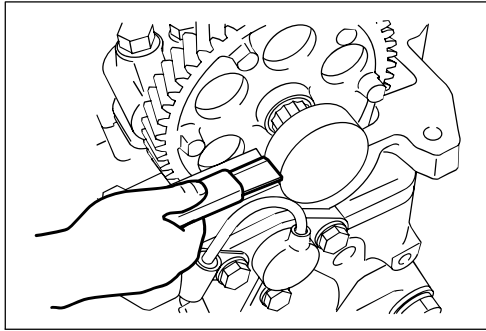

SAPH300020900016

1. Installation of head cover

- (1) Remove liquid gasket near the side of the cylinder plug at the front/rear ends of the camshaft housing, using a scraper.

⚠ CAUTION • If there is oil leak from the cylinder plug, do not remove the cylinder plug.

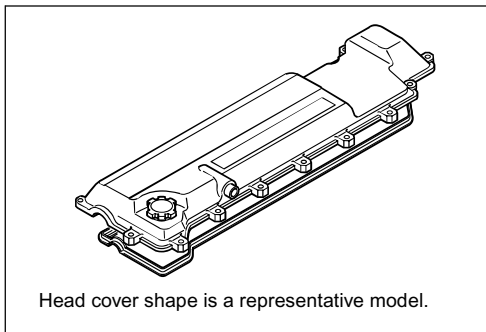

Head cover shape is a representative model.

SAPH300020900017

- (2) Wipe dirt (including liquid gasket) and oil on the joint surfaces of the head cover and the camshaft housing. Install a new gasket on the head cover.

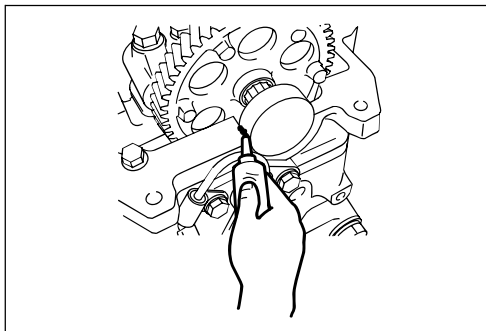

SAPH300020900018

- (3) Apply the liquid gasket [Threebond TB1207B(black) or equivalent] near the side of the cylinder plug immediately before installation of the head cover.

⚠ CAUTION • Apply the liquid gasket at the width of 1.5 to 2.5 mm{0.0591 to 0.0984 in.}

- Install the oil cooler within 20 minutes after application of the liquid gasket.
- Never apply the liquid gasket to the upper semi-circle of the cylinder plug.

- (4) Put the head cover on the camshaft housing and tighten bolts.

Tightening torque : 28.5 N · m {290 kgf · cm, 21 lbf · ft}

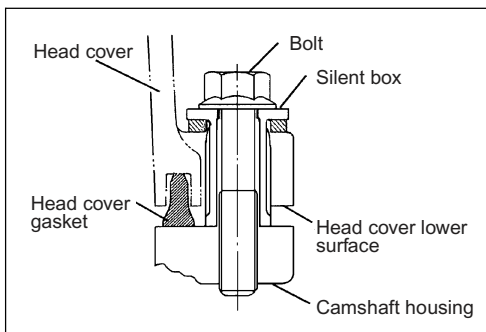

SAPH300020900019

Overhaul of cylinder head

JP30002090702001

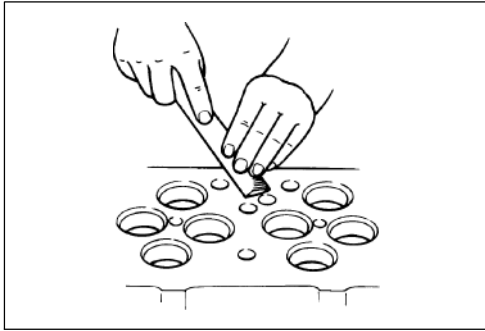

SAPH300020900020

1. Cleaning of cylinder head

- (1) Remove carbon or other deposit using a scraper.
- (2) Clean the cylinder head.

⚠ CAUTION • To remove carbon or other deposit, do not damage the lower surface of the cylinder head.

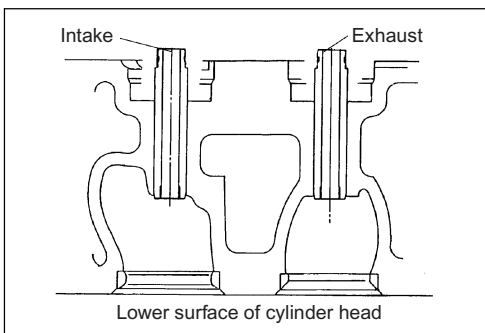

SAPH300020900021

2. Replacement of valve guide

- (1) Remove the valve stem seal.
- (2) Remove the valve guide using a brass bar or press.
- (3) When a new valve guide is assembled, do not pry the end in assembly and press fit using a special tool.

Special tool : 380100030 Guide

⚠ CAUTION • In press fit, be careful not to damage the valve stem at the upper/lower ends of the guide.

- In press fit, be sure to apply engine oil to the circumference of the valve guide.

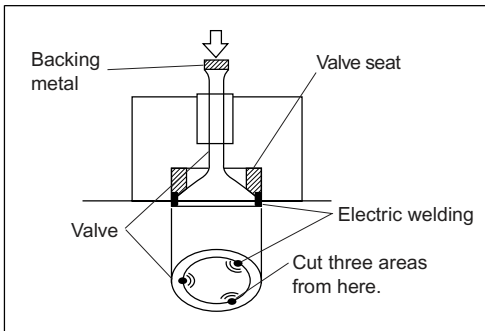

SAPH300020900022

3. Replacement of valve seat

⚠ CAUTION • The valve seat replacement procedure below may damage the cylinder head depending on the case. It is recommended that a request for replacement be made to a machining vendor.

- (1) If the valve seat is replaced, use an out-of-use valve. After cutting three pieces from the valve circumference, weld them to the valve seat.

⚠ CAUTION • Apply grease to protect the cylinder head lower surface from welding spatter before work.

- (2) Put a backup metal (e.g. brass bar) at the valve stem head and pull out the valve seat using a press.
- (3) Remove welding spatter or dirt on the valve seat surface.

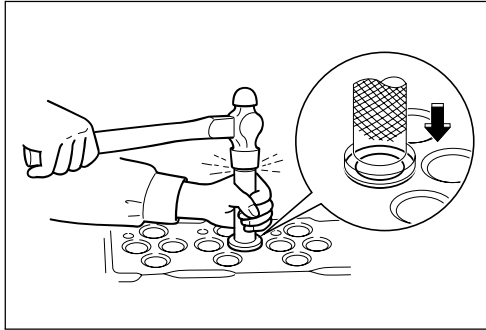

SAPH300020900023

- (4) Heat the cylinder head to approx. 80 to 100 °C and strike the cooled valve seat into the mounting area of the cylinder head.

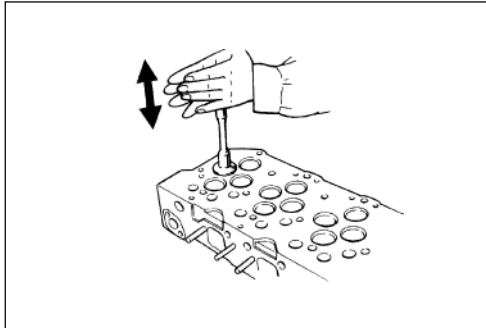

SAPH300020900024

- (5) Apply small amount of lapping compound to the contact surface between the valve and the valve seat.
- (6) Strike gently while turning the valve using a tool for adjustment.

Valve lapping tool

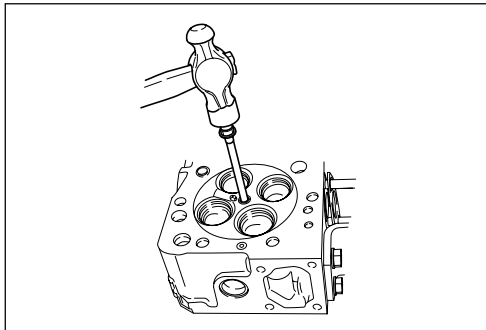

SAPH300020900025

4. Replacement of nozzle seat

- (1) Tap the nozzle seat from the cylinder head lower part. Then, put an appropriate bolt inside.
- (2) Hit the bolt head using a hammer and pull out the nozzle seat toward the the cylinder head upper part.
- (3) Remove the O-ring from the cylinder head.

⚠ CAUTION • After pulling out the nozzle seat, be sure to remove deposit such as remaining liquid gasket or dirt.

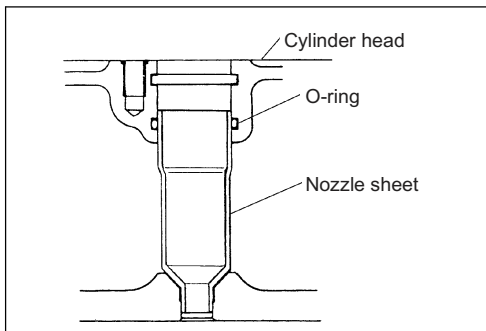

SAPH300020900026

- (4) After attaching a new O-ring into the nozzle seat hole of the cylinder head, apply the liquid gasket [Threebond TB1211 (white) or equivalent] at the lower part of a new nozzle seat and assemble it on the cylinder head.

⚠ CAUTION • Be sure to replace the O-ring with a new part. Reuse may cause water leak or gas leak, resulting in overheat or crack of the cylinder head.

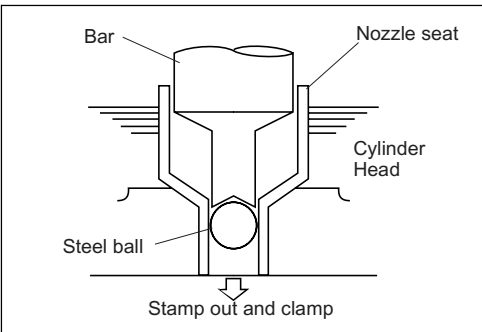

SAPH300020900027

- (5) Clamp the nozzle seat using a special tool.

Special tool : 380100031 Bar

380100032 Steel ball

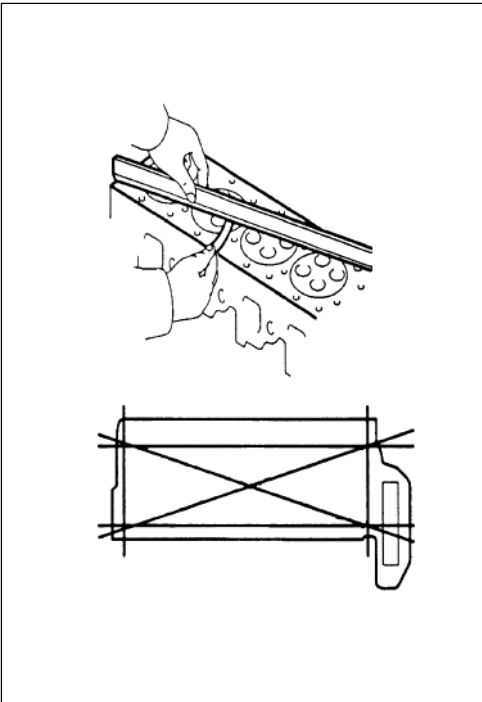

SAPH300020900028

5. Inspection of cylinder head

- (1) Inspection of cylinder head distortion
- a. Measure distortion of the cylinder head lower surface and the manifold mounting surface using a ruler.

Standard value (mm{in.})	Service limit (mm{in.})
Longitudinal direction 0.06{0.0024}	0.2{0.0079}
Square direction 0.03{0.0012}	

- b. If the measurement value is beyond the service limit, replace it.

⚠ CAUTION • **Repair of the lower surface by grinding can change backlash of the timing gear. Do not grind it.**

- (2) Inspection of cylinder head crack
- a. With dye penetrant test method (red check), make sure that there is no crack or damage in the cylinder head.

Cylinder Block

Part layout

JP30002090402002

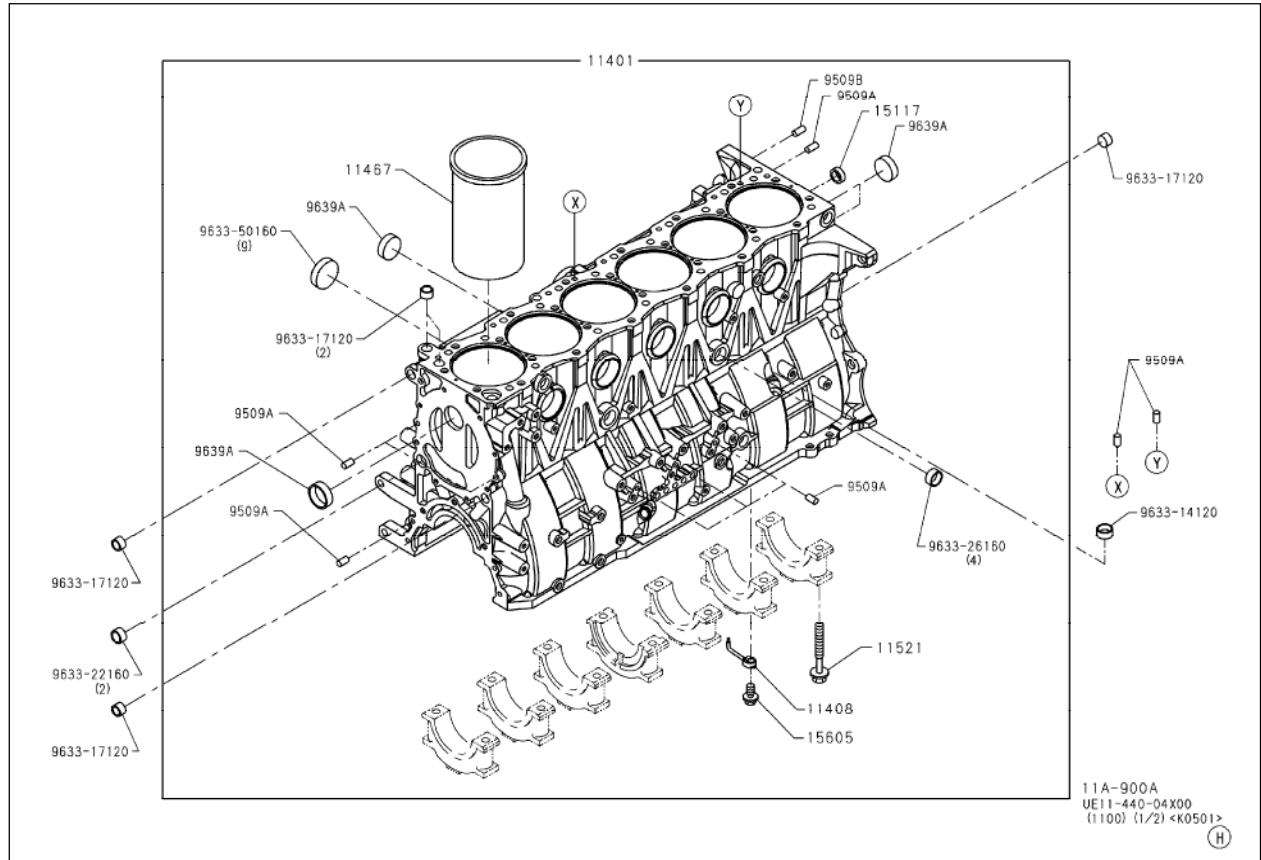

SAPH300020900029

11401	Cylinder block assembly	11467	Cylinder liner
11408	Cooling jet		

Tightening torque

11521	69N · m {700kgf · cm, 51lbf · ft} +90° +45°	15605	22N · m {220kgf · cm, 16lbf · ft}
-------	---	-------	-----------------------------------

Overhaul

JP30002090702002

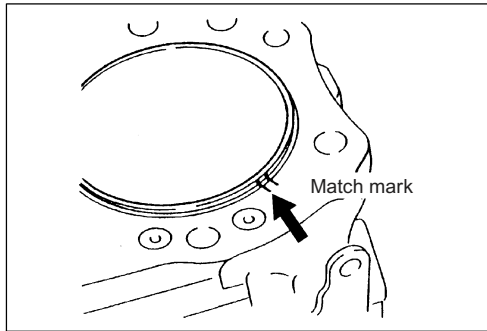

SAPH300020900030

1. Replacement of cylinder liner

- (1) Put match marks on the flange surfaces of the cylinder block and the cylinder liner using a oil based marker.

- CAUTION**
- Store removed cylinder liners for each cylinder number.
 - Never provide match marks with a punch.

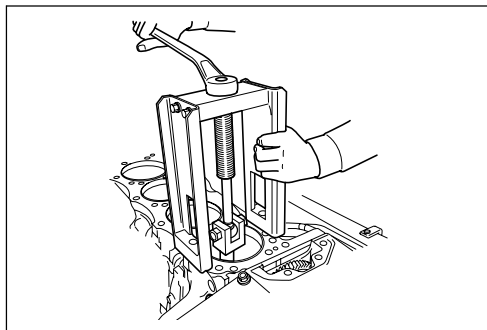

SAPH300020900031

- (2) Pull out the cylinder liner toward the cylinder block upper part using a tool.

Cylinder liner puller

- CAUTION**
- Be careful for handling of the cylinder liner. Do not reuse the cylinder liner which has been dropped.
 - Do not touch the cooling jet during work.

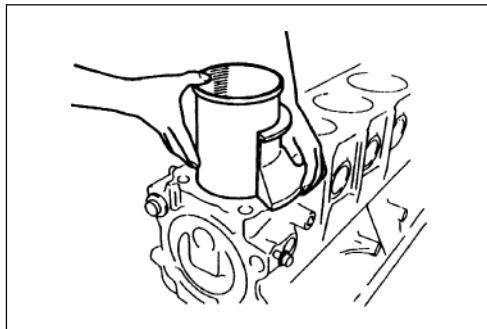

SAPH300020900032

- (3) Apply engine oil to the inner bore of the cylinder block.

- (4) Align the match mark of the cylinder liner with that of the cylinder block. Install the cylinder liner using a tool.

Guide

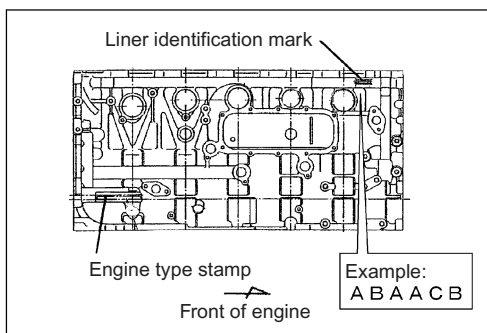

SAPH300020900033

- CAUTION**
- When a new cylinder liner is installed, install the cylinder liner with the same identification mark (A, B, C) stamped on the cylinder block.
 - The example in the figure shows that the #1 cylinder is a liner of B.

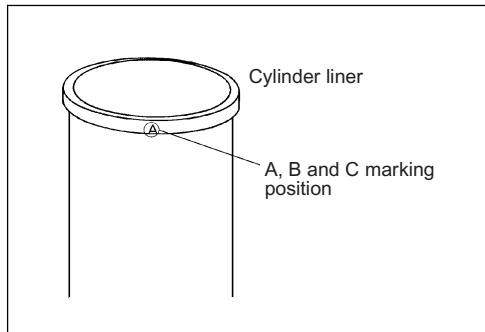

SAPH300020900034

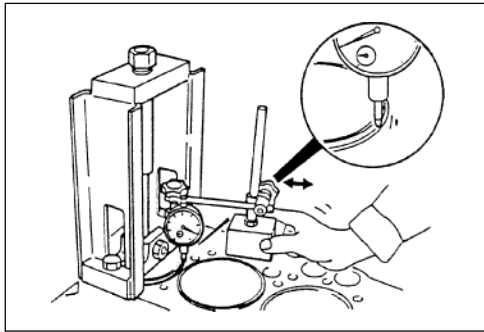

SAPH300020900035

2. Inspection of protrusion at cylinder liner flange

- (1) Fix the cylinder liner using a tool.
Tightening torque : 9.8 N · m {100 kgf · cm, 7 lbf · ft}
- (2) Measure protrusion of the flange using a dial gauge.

Cylinder liner puller

Standard value (mm{in.})	0.01 - 0.08 {0.0004 - 0.0031}
--------------------------	----------------------------------

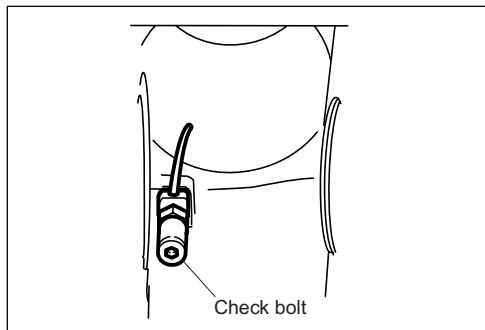

SAPH300020900036

3. Inspection and adjustment of cooling jet

- (1) Remove the standard oil check valve and install the cooling jet on the cylinder block using a special tool.
Special tool : 380100040 Check bolt

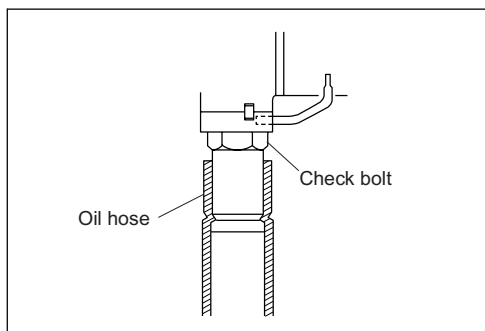

SAPH300020900037

- (2) Connect the injection test oil hose from the lower part of the cylinder block to the special tool check bolt.

⚠ CAUTION • Use new engine oil for injection of oil.

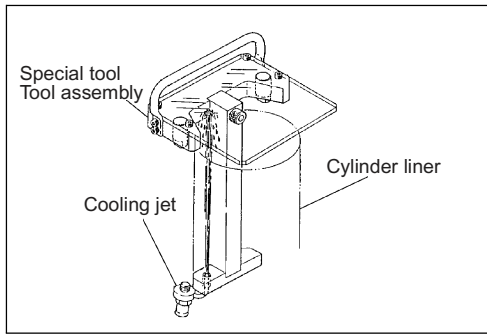

SAPH300020900038

- (3) Set a special tool on the cylinder block.
Special tool : 380100041 Tool assembly

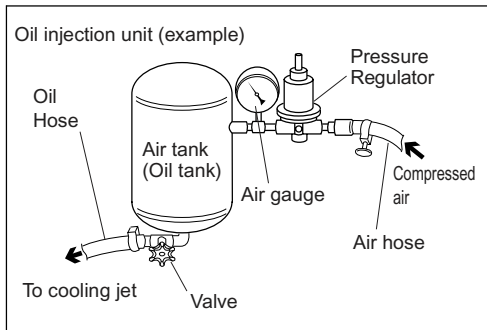

SAPH300020900039

- (4) Inject oil from the nozzle of the cooling jet at the hydraulic pressure of 196kPa{2kgf/cm², 28lbf/in.²}.

NOTICE • Refer to the drawing for the oil injection unit.

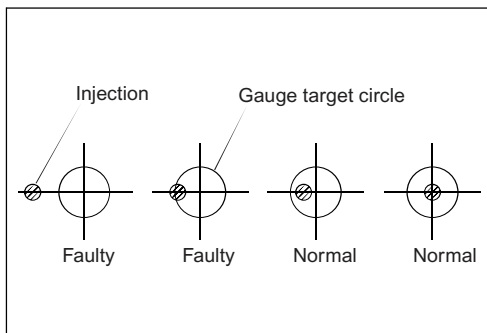

SAPH300020900040

- (5) When the injection center hits within the specified line of the gauge, it is considered normal.

CAUTION • Oil is susceptible to combustion due to spread. Do not use fire near around.
• Work at well ventilated place.

- (6) Make sure that the jet position check gauge hole at the tool assembly end may not interfere with the cooling jet pipe.

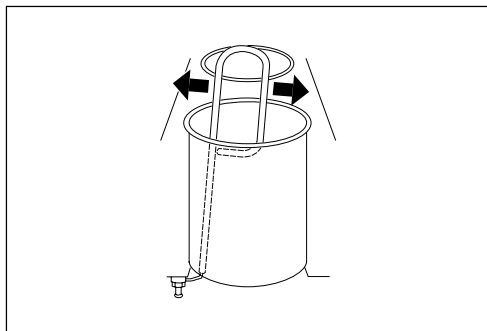

SAPH300020900041

- (7) If injection does not hit the target circle, correct it with a special tool.

Special tool : 380100039 Tool

- (8) If it cannot be corrected, install a new cooling jet for reinspection.
- (9) Remove the check bolt and install the cooling jet on the cylinder block using the genuine oil check valve.
Tightening torque : 22 N · m {220 kgf · cm, 16 lbf · ft}
- (10) After assembly of the piston, make sure that the cooling jet does not interfere with the piston at the piston bottom dead center.

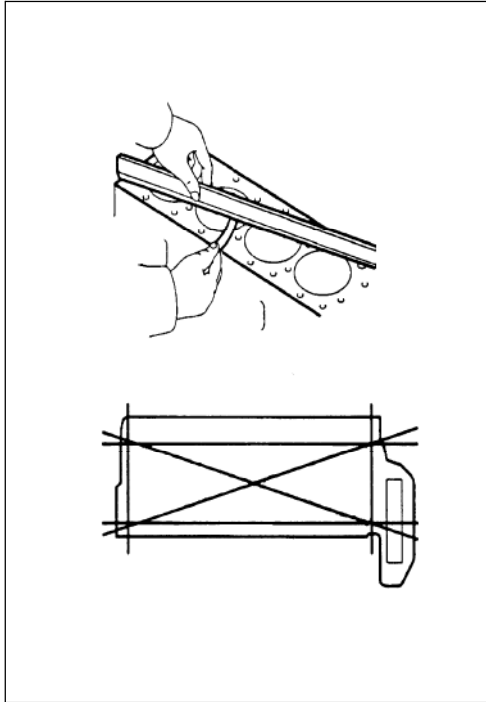

SAPH300020900042

4. Inspection of cylinder block

- (1) Inspection of cylinder block distortion
 - a. Measure distortion on the cylinder block using a ruler.

Standard value (mm{in.})	Service limit (mm{in.})
Longitudinal direction 0.06{0.0024}	0.2{0.0079}
Square direction 0.03{0.0012}	

- b. If the measurement value is beyond the service limit, replace it.

⚠ CAUTION • **Repair of the upper surface by grinding can change backlash of the timing gear. Do not grind it.**

- (2) Inspection of cylinder block crack
 - a. With dye penetrant test method (red check), make sure that there is no crack or damage in the cylinder block.

Replacement of flywheel housing

JP30002090702003

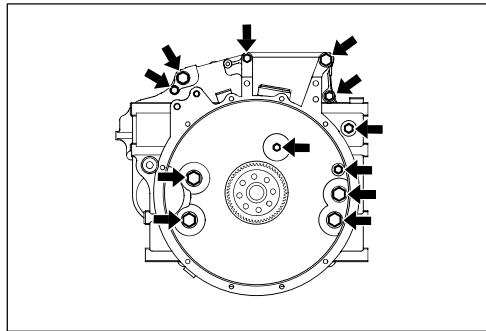

SAPH300020900044

1. Removal of flywheel housing

- (1) Remove bolts and remove the flywheel housing.

⚠ CAUTION • Remove bolts fixing the flywheel housing from the cylinder block.

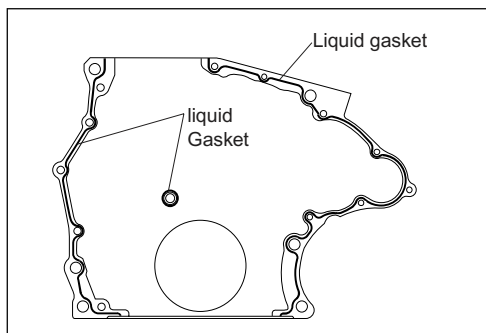

SAPH300020900045

2. Installation of flywheel housing

- (1) Remove contamination from the joint surfaces of the flywheel housing and the rear end plate using a scraper.
- (2) Apply the liquid gasket [Threebond TB1207D (silver) or equivalent] to the flywheel housing as shown in the figure.

⚠ CAUTION • Apply it continuously.
 • Apply the liquid gasket at the width of 1.5 to 2.5 mm {0.0591 to 0.0984 in.}.
 • Install the oil cooler within 20 minutes after application of the liquid gasket.

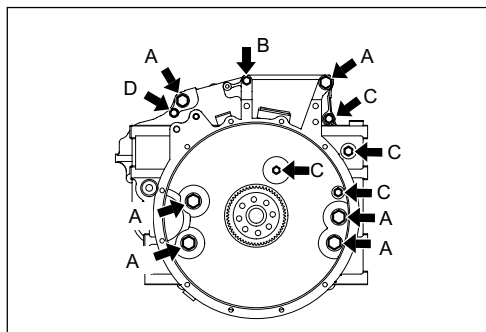

SAPH300020900046

- (3) Install the flywheel housing on the cylinder block with bolts.

Tightening torque :

196 N · m {2,000 kgf · cm, 145 lbf · ft} (Area A)

36 N · m {370 kgf · cm, 27 lbf · ft} (Area B)

55 N · m {560 kgf · cm, 41 lbf · ft} (Area C)

⚠ CAUTION • Tighten bolts fixing the flywheel housing from the cylinder block.

Replacement of rear end plate

JP30002090702004

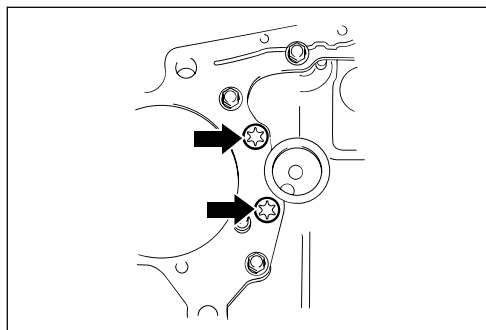

SAPH300020900047

1. Removal of rear end plate

- (1) Remove bolts.
- (2) Remove the Torx bolt using a special tool.

Special tool : 380100037 Socket wrench

2. Installation of rear end plate

- (1) Install the rear end plate and a new gasket with bolts.

⚠ CAUTION • Make sure that there is no dirt or foreign matter on the installation surface of the cylinder block and the screw holes.

- (2) Apply sealant (Super 5M or equivalent) to the thread of the Torx bolt.

- (3) Install the Torx bolt using a special tool.

Special tool : 380100037 Socket wrench

Tightening torque : 55 N·m {560 kgf·cm, 41 lbf·ft}

- (4) Cut the rear end plate gasket with a scraper to be flush to the upper/lower surfaces of the cylinder block.

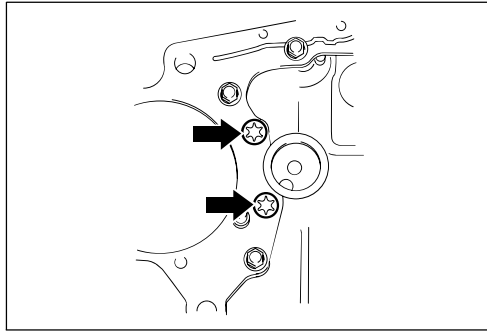

SAPH300020900047

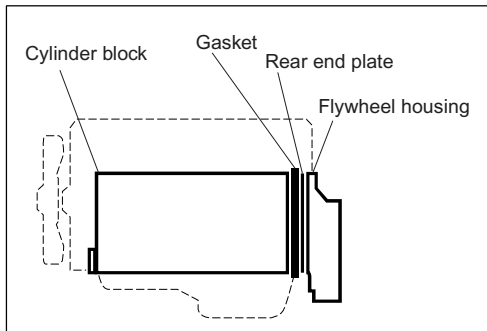

SAPH300020900048

Replacement of crankshaft front oil seal

JP30002090704005

1. Removal of crankshaft front oil seal

- (1) Install the plate of the special tool oil seal puller on the crankshaft using two crankshaft damper mounting bolts.

Special tool : 380100028 Oil seal puller

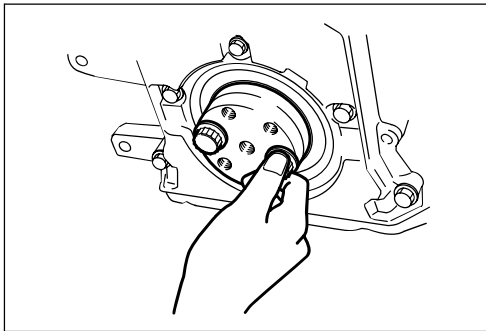

SAPH300020900049

- (2) Hook the special tool oil seal puller with the tab of the crankshaft front oil seal and install the hook on the plate of the special tool oil seal puller with accompanying bolts.

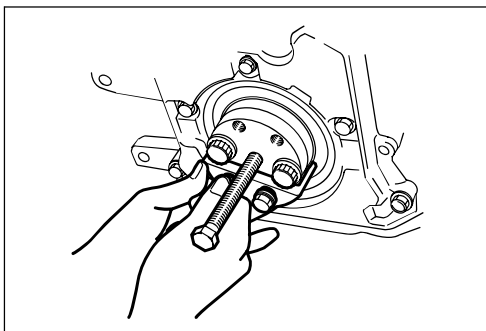

SAPH300020900050

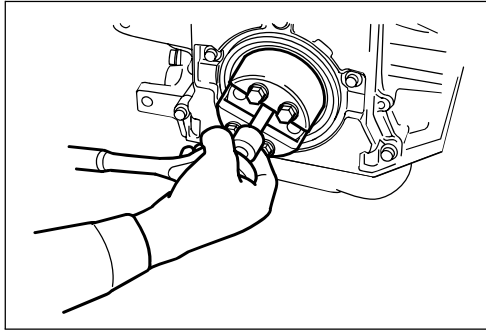

SAPH300020900051

- (3) Remove two bolts which installed the plate of the special tool oil seal puller on the crankshaft.
- (4) Attach the accompanying center bolt to the special tool oil seal puller and tighten it. Pull out the crankshaft front oil seal.

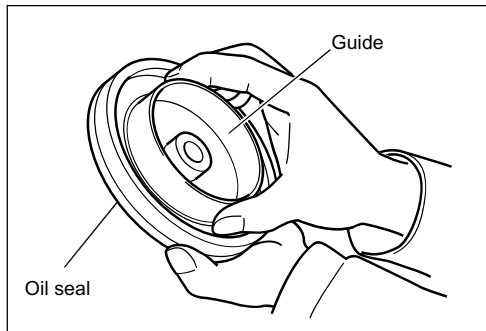

SAPH300020900052

2. Installation of crankshaft front oil seal

- (1) Insert a new crankshaft oil seal into the guide of the oil seal press.

Special tool : 380100029 Oil seal installer

⚠ CAUTION • Be careful for front/rear directions of the crankshaft front oil seal. (The felt surface is at the crankshaft damper side.)

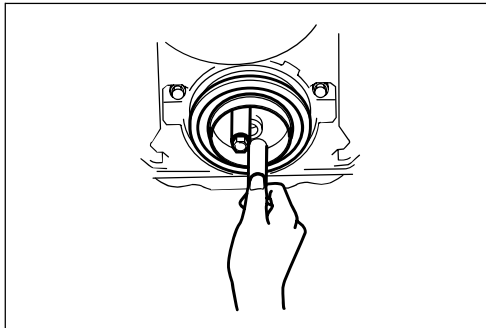

SAPH300020900053

- (2) Remove contamination from the joint surface of the crankshaft front oil seal and the cylinder block.
- (3) Apply small amount of engine oil to the seal area of the crankshaft front oil seal.
- (4) Install the oil seal press guide inserting a new crankshaft front oil seal with accompanying guide bolts on the crankshaft.

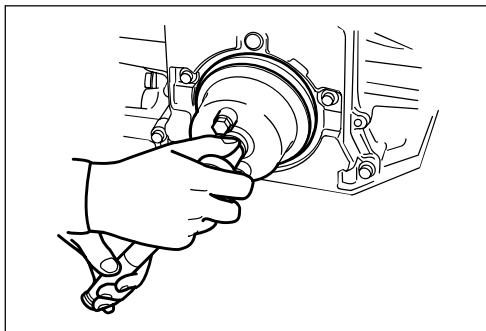

SAPH300020900054

- (5) Align the oil seal press hole to the guide bolt and insert the oil seal press.
- (6) Attach the accompanying center bolt to the oil seal press and tighten it until stop. Press fit the crankshaft front oil seal.

Replacement of crankshaft rear oil seal

JP30002090704006

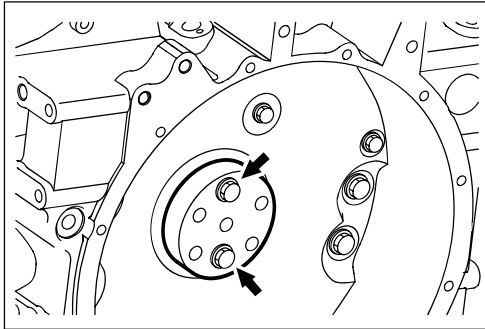

SAPH300020900055

1. Removal of crankshaft rear oil seal

- (1) Install the plate of the special tool oil seal puller on the crankshaft using two flywheel assembly mounting bolts.
Special tool : 380100034 Oil seal remover

CAUTION • Align the large hole of the plate with the collar dowel of the crankshaft.

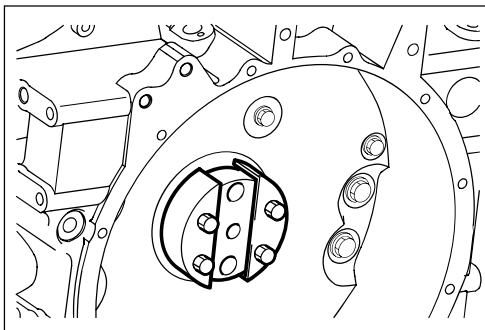

SAPH300020900056

- (2) Hook the oil seal puller with the tab of the crankshaft rear oil seal and install the hook on the plate of the oil seal puller with accompanying bolts.

- (3) Remove two bolts which installed the plate of the oil seal puller on the crankshaft.

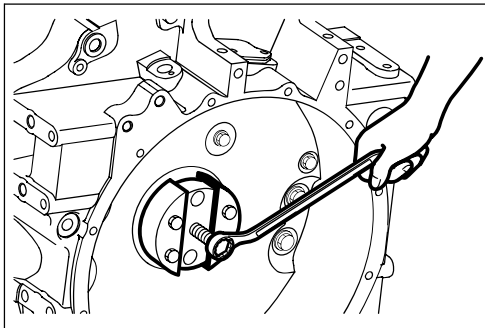

SAPH300020900057

- (4) Attach the accompanying center bolt to the oil seal puller and tighten it. Pull out the crankshaft rear oil seal.

2. Installation of crankshaft rear oil seal

- (1) Insert a new crankshaft rear oil seal into the guide of the oil seal press.

Special tool : 380100038 Oil seal installer

CAUTION • Be careful for front/rear directions of the crankshaft rear oil seal. (The felt surface is at the flywheel side.)

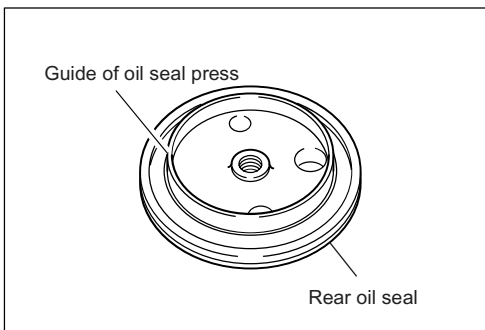

SAPH300020900058

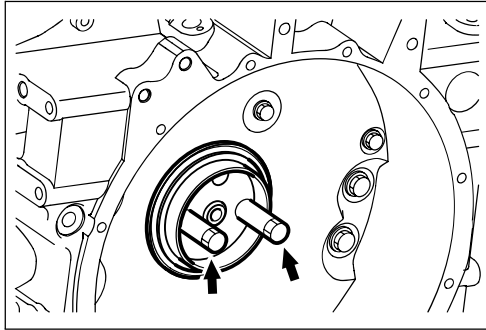

- (2) Remove contamination from the joint surface of the crankshaft rear oil seal and the flywheel housing
- (3) Apply small amount of engine oil to the seal area of the crankshaft rear oil seal.
- (4) Install the oil seal press guide inserting a new crankshaft rear oil seal with accompanying guide bolts on the crankshaft.

⚠ CAUTION • **Align the large hole of the guide with the collar dowel of the crankshaft.**

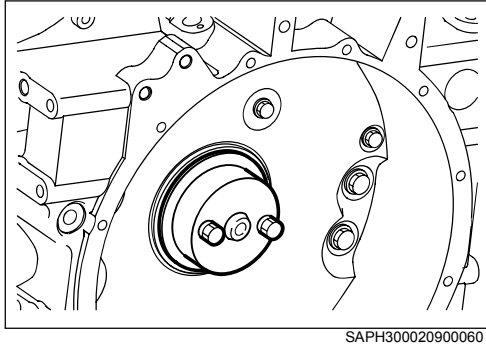

- (5) Align the oil seal press hole to the guide bolt and insert the oil seal press.

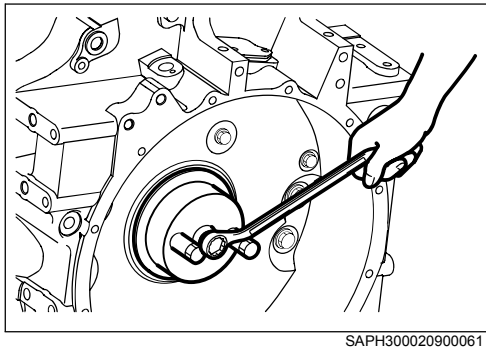

- (6) Attach the accompanying center bolt to the oil seal press and tighten it until stop. Press fit the crankshaft rear oil seal.

Main Moving Parts

Part layout

JP30002090402004

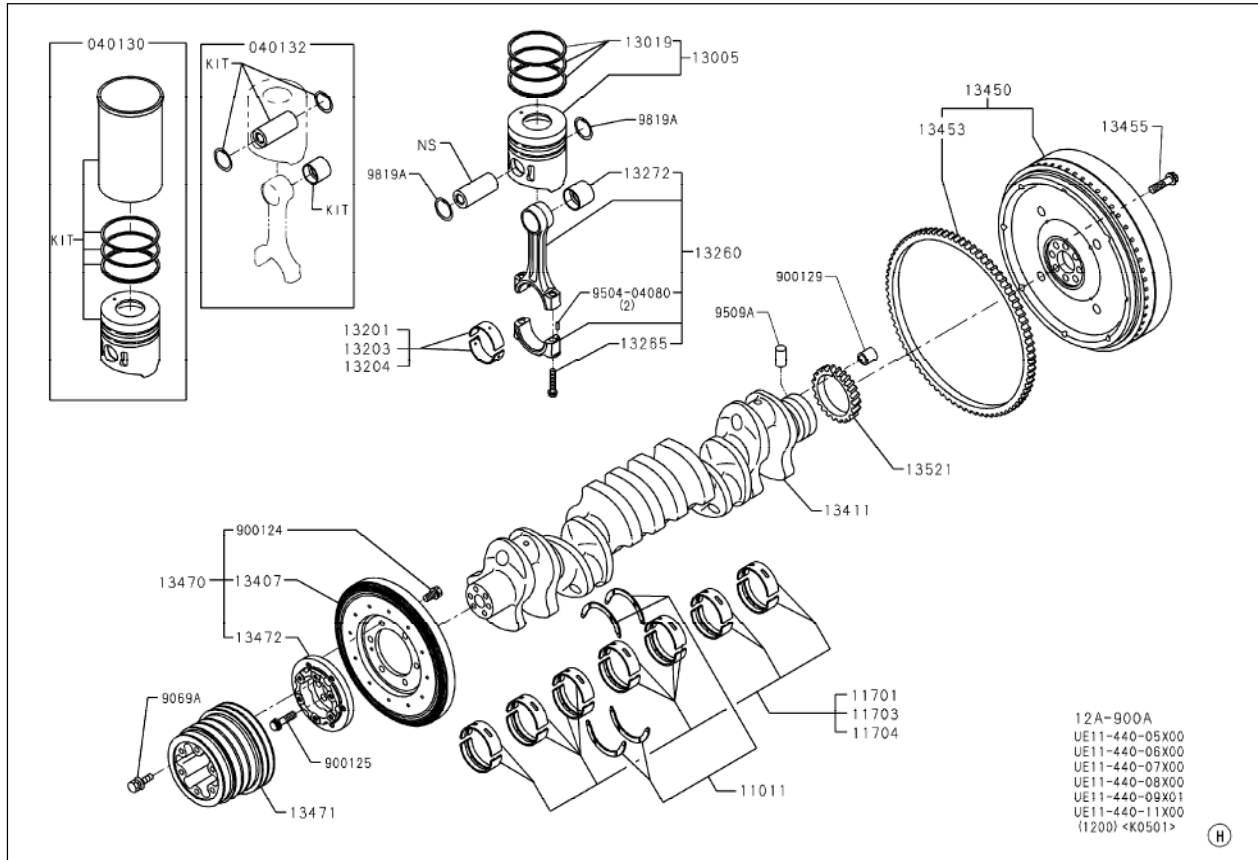

12A-900A
 UE11-440-05X00
 UE11-440-06X00
 UE11-440-07X00
 UE11-440-08X00
 UE11-440-09X01
 UE11-440-11X00
 (1200) <R0501>



SAPH300020900062

11011	Thrust bearing	13407	Crankshaft damper
11701	Main bearing	13411	Crankshaft
11703	Main bearing US 0.25	13450	Flywheel assembly
11704	Main bearing US 0.50	13453	Ring gear
13005	Piston and piston ring set	13471	Crankshaft pulley
13201	Bearing	13521	Crankshaft gear
13260	Connecting rod assembly	9819A*	Retainer ring

*Parts not to be reused.

Tightening torque

13265	69N·m {700kgf·cm, 51lbf·ft} +90° +45°	900125	118N·m {1,200 kgf·cm, 87lbf·ft}
13455	186N·m {1,900 kgf·cm, 137lbf·ft}		

Replacement of piston and connecting rod

JP30002090702005

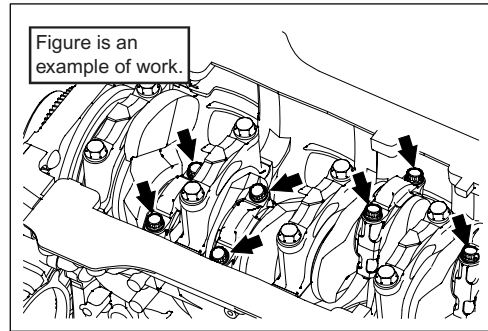

SAPH300020900063

1. Removal of piston

- (1) Remove bolts and remove the connecting rod cap.

- CAUTION**
- Insert a large flat tip screwdriver into the flywheel gear from the flywheel housing inspection hole to prevent turning of the crankshaft.
 - Store removed connecting rod cap for each cylinder number so that combinations of the connecting rod and the connecting rod cap may not be changed.

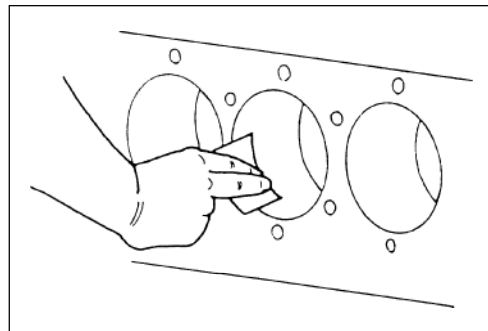

SAPH300020900064

- (2) Remove carbon on the cylinder liner inner surface with a scraper or a sand paper (No. 150 or so) in the circumferential direction.

- CAUTION**
- Do not damage parts lower than the carbon deposit area.

- (3) Fix the cylinder liner with bolts and a plate.

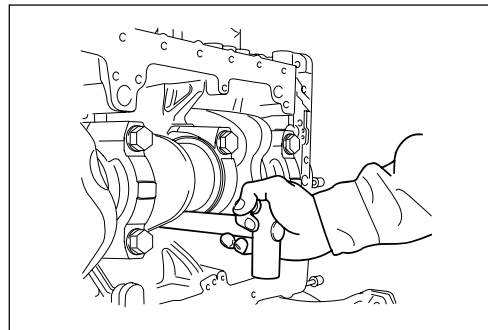

SAPH300020900065

- (4) Hit the connecting rod from underneath the engine using a handle of a hammer. Remove the piston together with the connecting rod.

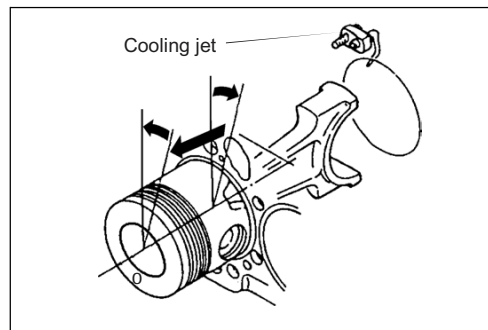

SAPH300020900066

- NOTICE**
- In removing the piston, rotate the connecting rod as shown in the figure. Do not bend the cooling jet.

- CAUTION**
- Store removed pistons and connecting rods for each cylinder number.
 - Be careful not to touch the cooling jet.

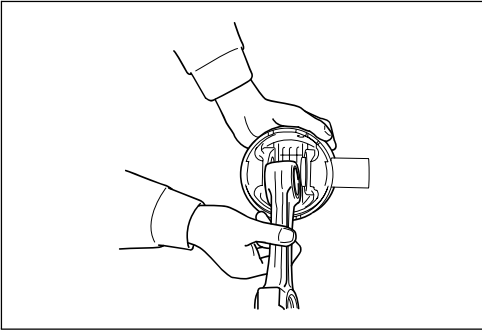

SAPH300020900067

2. Disassembly of piston and connecting rod

- (1) Remove the retainer ring using snap ring pliers.
- (2) Remove the piston pin using the brass bar and disconnect the piston from the connecting rod.

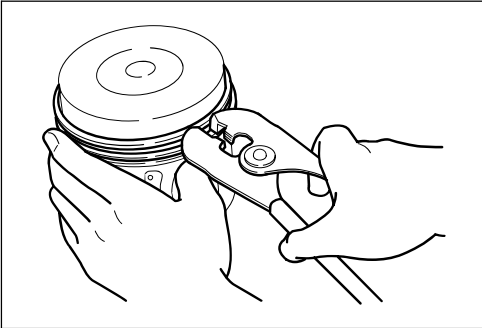

SAPH300020900068

- (3) Remove the piston ring using a tool.

- ⚠ CAUTION**
- Since the piston ring is susceptible to damage, be careful for handling.
 - Store piston rings for each cylinder number.
 - Store the piston rings so that the upper and lower surfaces may be identified.

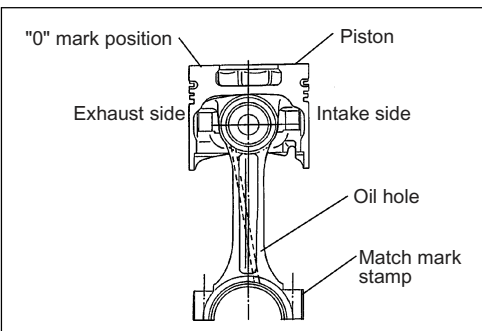

SAPH300020900069

3. Assembly of piston and connecting rod

- (1) Install the piston on the connecting rod so that the "0" mark on the piston may be opposite to the match mark stamp on the connecting rod
- (2) Install a new retainer ring using a snap ring pliers.

- ⚠ CAUTION**
- Make sure that there is no backlash in the retainer ring.

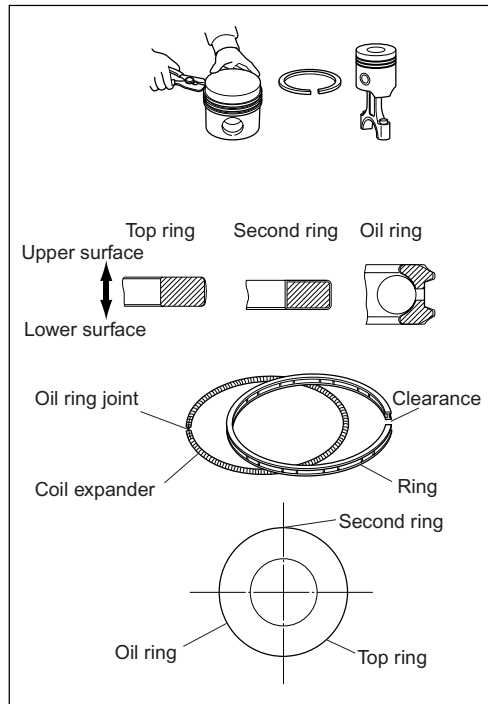

- (3) Face the side with the piston ring identification print upward and install in the order of the oil ring, second ring and top ring using a special tool.

NOTICE • The identification print is present only on the secondary ring and the top and bottom of the top ring and the oil ring are not identified.

Piston ring expander

- (4) Connect the joint of the coil expander and fit the oil ring inside the ring. Offset the coil expander joint with the ring joint by 180 deg for installation.
- (5) Allocate the joints of the piston ring with uniform intervals as shown in the figure.

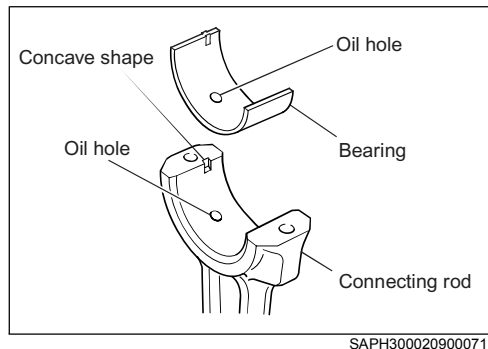

4. Installation of piston and connecting rod

- (1) Allocate the joints of the piston ring with uniform intervals as shown in the figure.
- (2) Install the connecting rod bearing to suit concave shape of the connecting rod.

CAUTION • Make sure that the oil hole of the connecting rod bearing is aligned with the oil hole of the connecting rod.

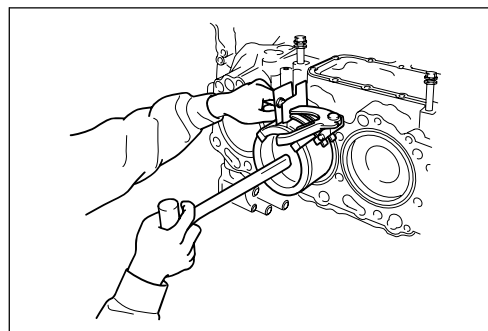

- (3) Apply engine oil to the piston, cylinder liner and connecting rod bearing and compress the piston ring using a special tool.

Piston ring holder

CAUTION • Make sure that there is no deformation or damage to the special tool piston ring holder.

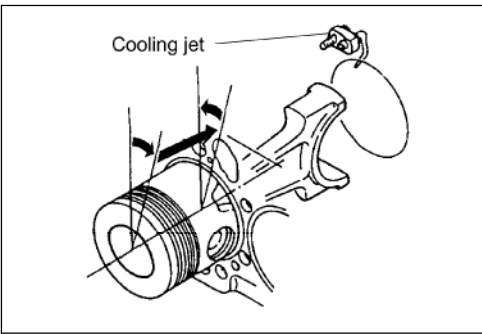

SAPH300020900073

- (4) Insert the piston carefully so that the connecting rod may not come in contact with the cooling jet.

- ⚠ CAUTION**
- Face the "0" mark on the piston toward the exhaust side for insertion.
 - Set the crankshaft of the cylinder as the top dead center for assembly.
 - Do not damage the cylinder liner, crankshaft and cooling jet during work.

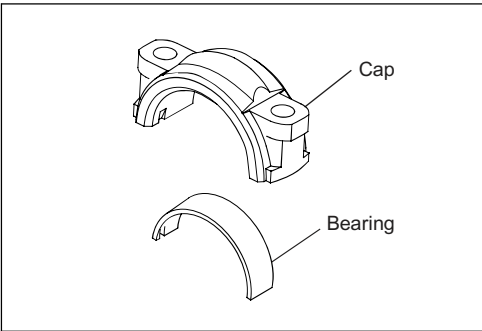

SAPH300020900074

- (5) Install the connecting rod bearing to suit concave shape of the connecting rod cap.

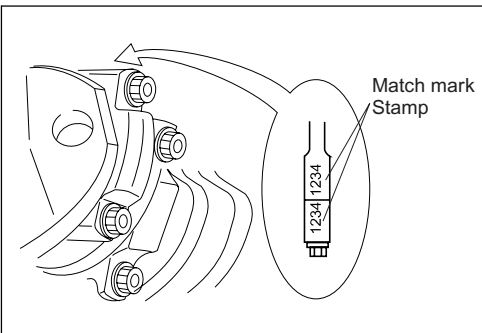

SAPH300020900075

- (6) Align the match mark of the connecting rod cap with that of the connecting rod and fix it with a dowel pin.

- ⚠ CAUTION**
- Do not change the combination between the connecting rod and the connecting rod cap.

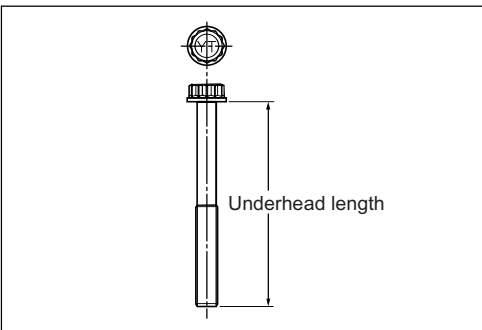

SAPH300020900076

- (7) Measure the underhead length of the connecting rod bolt using a vernier calipers. If it is out of the service limit, replace it with a new one.

Service limit (mm{in.})	68.0{2.6772} or less
--------------------------------	-----------------------------

- (8) Apply engine oil to the connecting rod bolt thread and the seat and install it on the connecting rod.

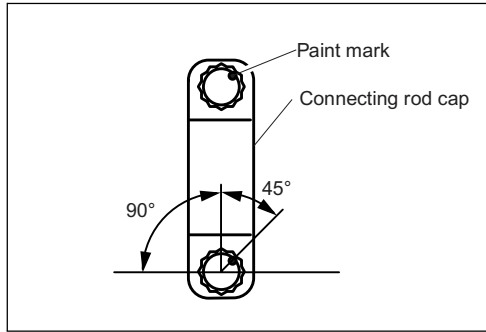

SAPH300020900077

- (9) Tighten the connecting rod bolt and mark the bolt head in the same direction with paint.

Tightening torque : 69 N·m {700 kgf·cm, 51 lbf·ft}

- (10) Retighten the connecting rod bolt 90 ° .
- (11) Retighten the connecting rod bolt further 45 ° .
- (12) Make sure that all marks are in the same direction.

⚠ CAUTION • If a bolt is turned excessively in retightening, do not loosen it.

Inspection of piston and connecting rod

JP30002090703001

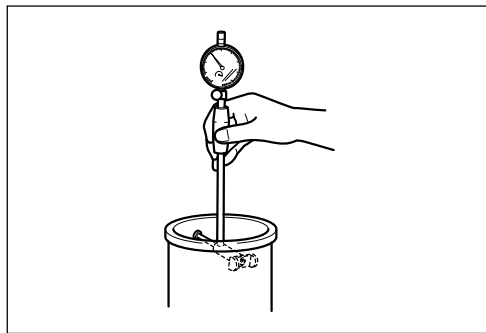

SAPH300020900078

1. Inspection of piston clearance

- (1) Measure the inner diameter of the cylinder liner sliding surface using a cylinder gauge.

Standard value (mm{in.})	Service limit (mm{in.})
112{4.4095}	112.15{4.4153}

- (2) Measure the piston outer diameter using a micrometer.

⚠ CAUTION • The measuring position is 23 mm{0.9055 in.} above the piston lower end and square to the pin hole.

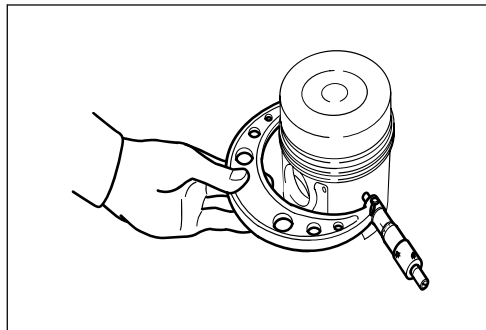

SAPH300020900079

Standard value (mm{in.})	111.9±0.008{4.4055±0.0003}
--------------------------	----------------------------

- (3) Calculate the difference between the inner diameter of the cylinder liner and the outer diameter of the piston. If it is beyond the standard value, replace the cylinder liner and the piston.

Standard value (mm{in.})	0.048 - 0.112{0.0019 - 0.0044}
--------------------------	--------------------------------

2. Inspection of clearance between piston ring and ring groove

- (1) Measure the piston ring width (B width) using a micrometer. If it is beyond the service limit, replace the piston ring.

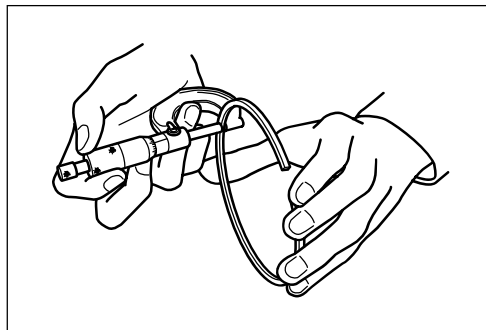

SAPH300020900080

	Standard value (mm{in.})	Service limit (mm{in.})
Top ring	2.5{0.0984}	2.40{0.0945}
Second ring	2{0.0787}	1.90{0.0748}
Oil ring	4{0.1575}	3.90{0.1535}

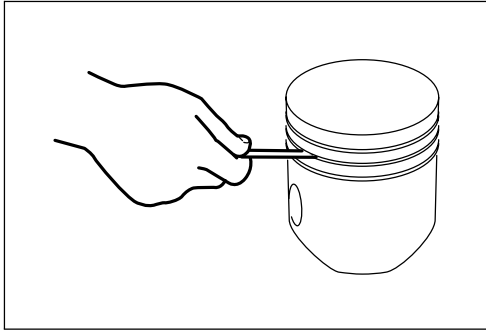

SAPH300020900081

- (2) Measure the piston ring groove using a thickness gauge. If it is out of the service limit, replace the piston.

	Standard value (mm{in.})	Service limit (mm{in.})
Top ring groove	2.5{0.0984}	2.70{0.1063}
Second ring groove	2{0.0787}	2.20{0.0866}
Oil ring groove	4{0.1575}	4.10{0.1614}

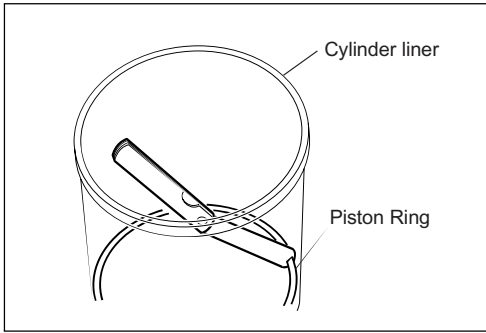

SAPH300020900082

3. Inspection of piston ring joint clearance

- (1) Insert the piston ring into the cylinder liner by 80 mm horizontally using piston.
 (2) Measure the piston ring joint clearance using a thickness gauge. If it is out of the service limit, replace the piston ring.

	Standard value (mm{in.})	Service limit (mm{in.})
Top ring	0.3 - 0.40 {0.0118 - 0.0157}	1.5{0.0591}
Second ring	0.75 - 0.90 {0.0295 - 0.0354}	1.2{0.0472}
Oil ring	0.15 - 0.3 {0.0059 - 0.1181}	1.2{0.0472}

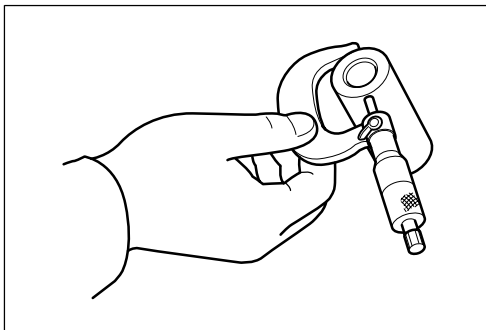

SAPH300020900083

4. Inspection of piston pin

- (1) Measure the outer diameter of the contact area of the piston pin with the piston boss using a micrometer.

Standard value (mm{in.})	Service limit (mm{in.})
37 {1.4567}	36.96{1.4551}

- (2) Measure the piston boss inner diameter using a cylinder gauge.

Standard value (mm{in.})	Service limit (mm{in.})
37 {1.4567}	37.05{1.4587}

- (3) Calculate the difference between the outer diameter of the piston pin contact area with the piston boss and the inner diameter of the piston boss. If it is out of the service limit, replace the piston pin.

Standard value (mm)	Service limit (mm{in.})
-0.002T-0.025L	0.05{0.0020}

T : Tightening allowance, L : Clearance

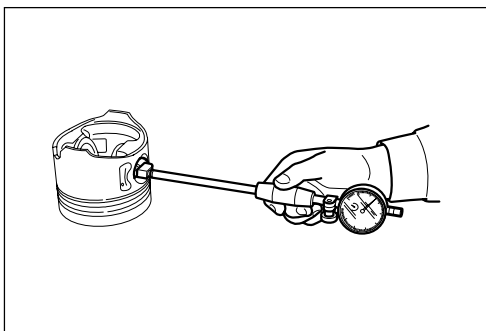

SAPH300020900084

Replacement of connecting rod bushing

JP30002090704007

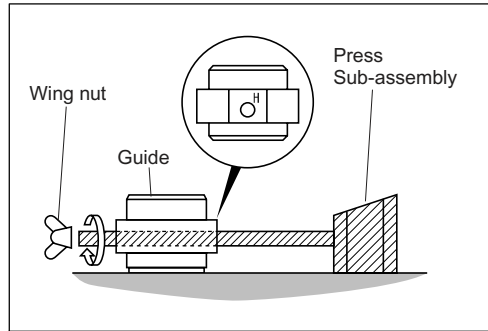

1. Removal of connecting rod bushing

- (1) Put the press sub-assembly together with the special tool guide nut and fix them using the wing nut.

Guide

Press sub-assembly

Wing nut

- ! CAUTION**
- Face "H" mark of the guide upward for assembly.
 - Assemble it on a level table and make sure that the lower end of the guide and the press sub-assembly is flat.

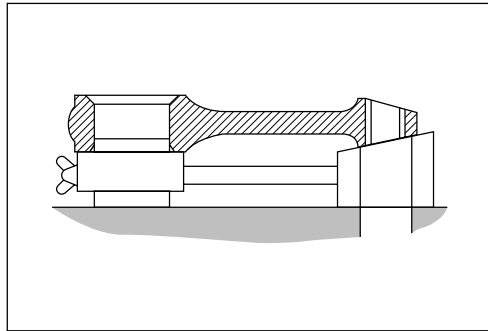

- (2) With the large end bearing removed, assemble the connecting rod and put it on the assembled tool.

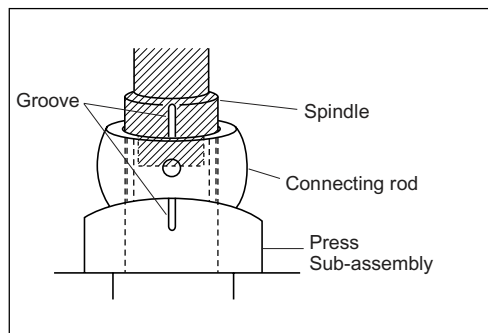

- (3) Install the spindle on the bushing of the connecting rod.

Spindle

- ! CAUTION**
- Align the press sub-assembly groove with the special tool spindle groove for installation.

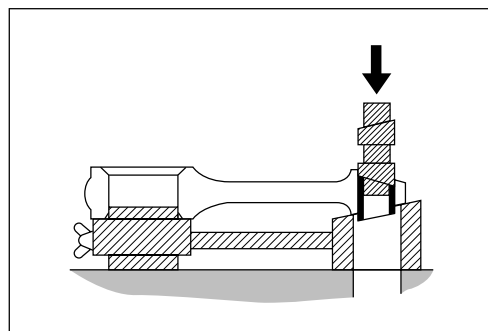

- (4) Remove the bushing of the connecting rod using a press.

- ! CAUTION**
- Move the press slowly.

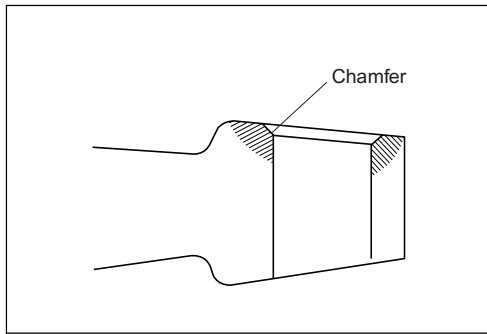

SAPH300020900089

- (5) Chamfer one side of the connecting rod small end uniformly according to the figure.

- CAUTION**
- Remove burr completely.
 - After chamfering, remove dirt from the inner surface at the small end and from the oil hole.

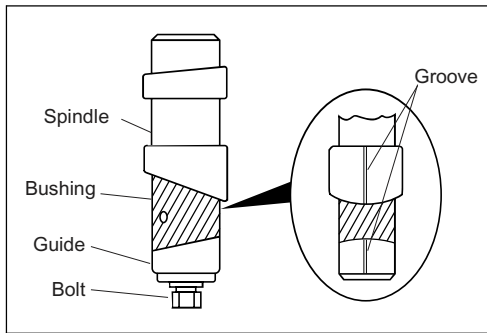

SAPH300020900090

2. Installation of connecting rod bushing

- (1) Install a new bushing on the spindle and install the special tool guide and the bolt.

**Spindle
Guide
Bolt**

Tightening torque :

5 - 6 N · m {50 - 70 kgf · cm, 3.5 - 4 lbf · ft}

- CAUTION**
- Align grooves of the guide and the spindle for installation.
 - Make sure that the edge of the spindle and the guide is in close contact.

- (2) Align the connecting rod oil hole with the bushing oil hole assembled on the special tool. Make sure that the groove of the spindle is in alignment with the groove of the press sub-assembly.

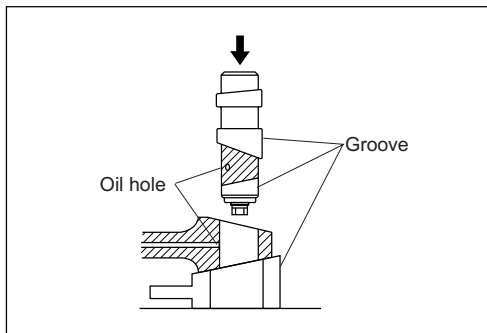

SAPH300020900091

- CAUTION**
- Place the connecting rod so that the chamfer side of the connecting rod small end inner diameter may be the bushing side
 - Apply engine oil to the inner diameter surface of the connecting rod.

- (3) Install the bushing on the connecting rod using a press.
 (4) Insert a rod with the diameter of 6 mm from the oil hole at the connecting rod large end and make sure that it goes through the oil hole at the small end.

- NOTICE**
- Displacement of oil holes may cause insufficient lubrication, resulting in seizure.

- (5) Insert a new piston pin and check if there is no drag or backlash.

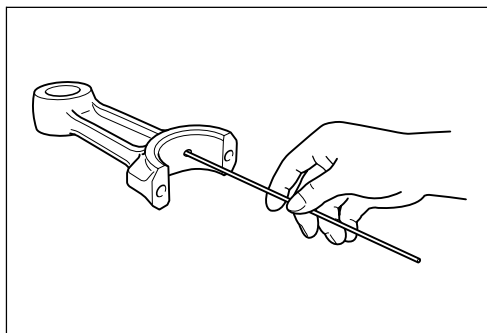

SAPH300020900092

Replacement of crankshaft

JP30002090704008

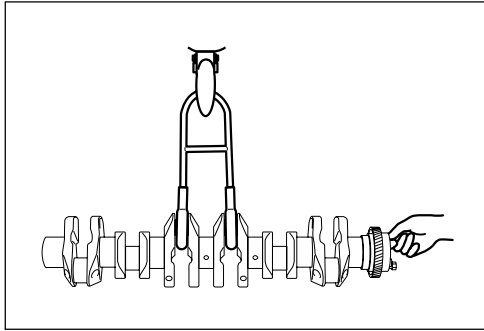

SAPH300020900093

1. Removal of crankshaft

- (1) Remove the main bearing cap and the crankshaft bearing. Remove the crankshaft using a hoist.

- ⚠ CAUTION**
- Since the part is heavy, be careful for handling.
 - Store removed main bearing caps and crankshaft bearings for each cylinder number.

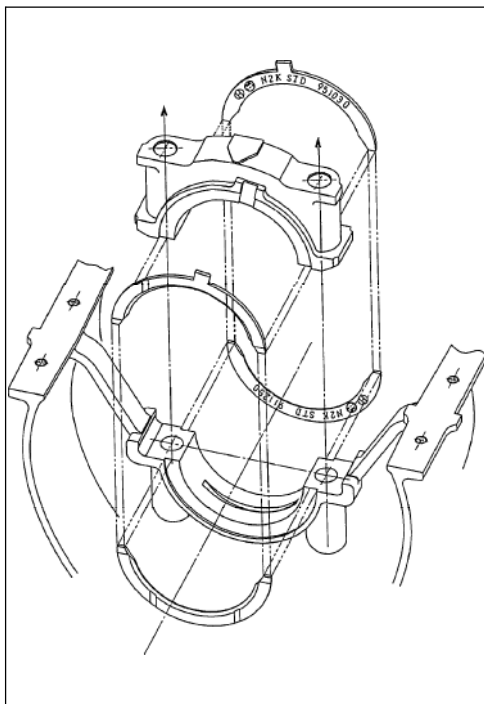

SAPH300020900094

2. Installation of crankshaft

- (1) Face the groove side (front) of the thrust bearing toward the crankarm and the part number side (back) toward the main bearing cap or the cylinder block. Install it on the cylinder block and the main bearing cap.

- ⚠ CAUTION**
- To prevent falling in assembly, apply engine oil or grease to the back of the thrust bearing.

- (2) Install the main bearing on the cylinder block and each bearing cap.

- ⚠ CAUTION**
- Assemble the bearing with oil hole on the cylinder block and assemble the bearing without oil hole on the cap.
 - Apply new engine oil to the sliding surfaces of each bearing.

- (3) Align the crankshaft with the cylinder block.

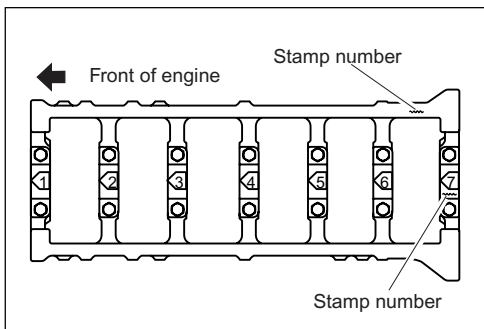

SAPH300020900095

- (4) Align the main bearing cap which has the thrust bearing and the main bearing with the cylinder block.

- ⚠ CAUTION**
- The pentagon mark on the main bearing cap should face the front of the vehicle. Align in the order of 1, 2, 3, 4, 5, 6 and 7 from the front.
 - Check the stamp number of each main bearing cap with the stamp number of the cylinder block.

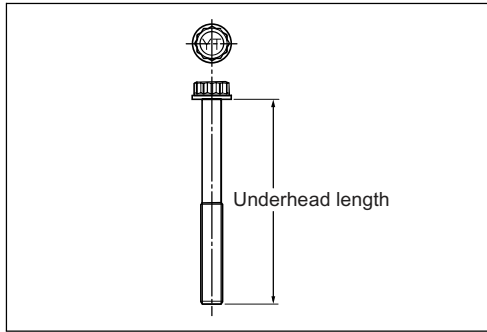

SAPH300020900076

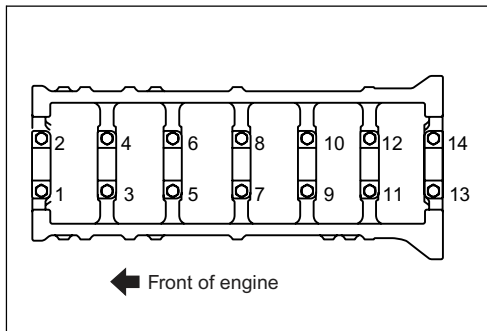

SAPH300020900096



SAPH300020900097

- (5) Measure the underhead length of the bearing cap bolt using a vernier calipers. If it is out of the service limit, replace it with a new one.

Service limit (mm{in.})	108{4.252}
-------------------------	------------

- (6) Apply engine oil to the bolt seat and the bolt thread of the bearing cap bolt.
- (7) Tighten the bearing cap bolt according to the sequence in the figure.
Tightening torque : 69 N · m {700 kgf · cm, 51 lbf · ft}
- (8) Loosen the bearing cap fixing the thrust bearing and hit the crankshaft gently at the front/rear end using a plastic hammer.
- (9) Loosen all bearing cap bolts.
- (10) Tighten the bearing cap bolt as in (7).
Tightening torque : 69 N · m {700 kgf · cm, 51 lbf · ft}
- (11) Mark bearing cap bolt heads in the same direction with paint.
- (12) Tighten 90 deg (1/4 turn) with the same order as in (7).
- (13) Retighten 45 deg (1/8 turn) as in (7).
- (14) Make sure that all paint marks are in the same direction.

⚠ CAUTION • If it is excessively retightened, do not loosen it.

- (15) After tightening, hit the front/rear ends of the crankshaft gently with a plastic hammer for initial fit.

⚠ CAUTION • Make sure that the crankshaft turns smoothly.
 • Measure the end play of the crankshaft and make sure that it is within the standard value.

Standard value (mm{in.})	Repair limit (mm{in.})	Service limit (mm{in.})
0.050 - 0.270 {0.0020 - 0.0106}}	0.50{0.0197}	1.270{0.0500}

Inspection of crankshaft

JP30002090703002

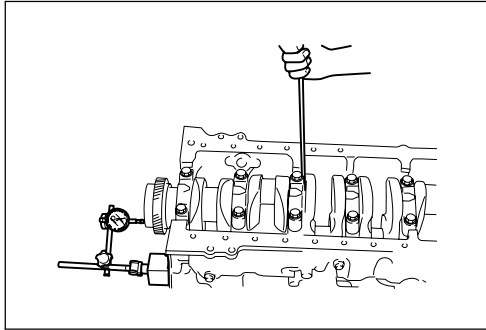

SAPH300020900098

1. Inspection of end play

- (1) Measure the end play of the crankshaft using a dial gauge. If it is beyond the repair limit, replace the thrust bearing. If it is beyond the service limit, replace the crankshaft.

Standard value (mm{in.})	Repair limit (mm{in.})	Service limit (mm{in.})
0.050 - 0.270 {0.020 - 0.0106}	0.50{0.0197}	1.270{0.0500}

NOTICE

- Standard width of thrust bearing 2.5mm{0.0984in.}

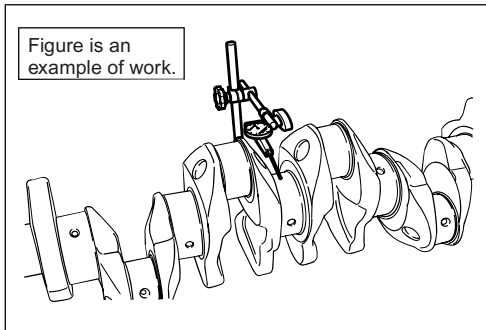

SAPH300020900099

2. Inspection of rotation runout

- (1) Measure the crankshaft rotation runout using a dial gauge. If it is beyond the repair limit, grind the crankshaft and use the undersize bearing.

Repair limit (mm{in.})	0.15{0.0060}
------------------------	--------------



SAPH300020900100

3. Inspection of journal wear

- (1) Measure the outer diameter of the crankshaft journal using a micrometer. If it is faulty, grind or replace the crankshaft. When the crankshaft is ground, use the undersize bearing.

Journal standard value (mm{in.})	80{3.1496}
----------------------------------	------------

Wear value (mm{in.})	Action
Eccentric wear 0.10{0.0039}	Regrind for correction.
Wear of 0.20{0.0079} or more	Regrind
Wear of 1.20{0.0472}	Replace the crankshaft.

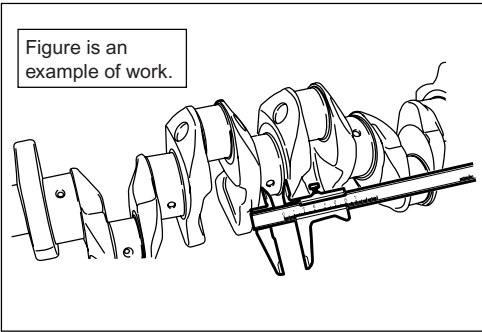

SAPH300020900101

- (2) Measure the crankshaft center journal width using a vernier calipers. If it is out of the service limit, replace the crankshaft.

Standard value (mm{in.})	Service limit (mm{in.})
36{1.4173}	37.0{1.4567}

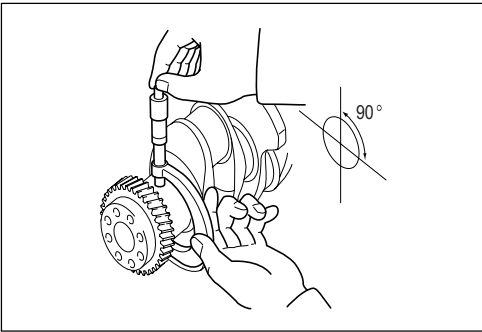

SAPH300020900102

4. Inspection of crankshaft oil clearance

- (1) Measure the outer diameter of the crankshaft journal using a micrometer.

Standard value (mm{in.})	Service limit (mm{in.})
80{3.1496}	78.8{3.1024}

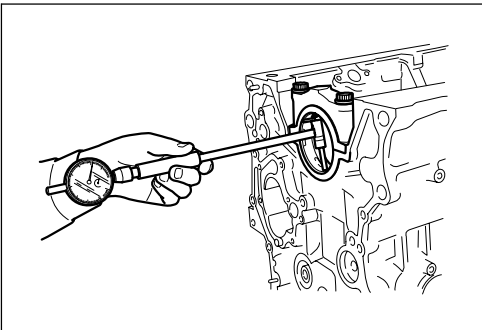

SAPH300020900103

- (2) Do not install the crankshaft. Install the crankshaft bearing and the main bearing cap on the cylinder block.
- (3) Measure the crankshaft bearing inner diameter using a cylinder gauge.
- (4) Calculate the difference between the outer diameter of the crankshaft journal and the inner diameter of the crankshaft bearing. If it is beyond the repair limit, grind the crankshaft and use the undersize bearing.

Standard value (mm{in.})	Repair limit (mm{in.})
0.051 - 0.102 {0.0020 - 0.0040}	0.2{0.0079}

NOTICE

- Standard bearing thickness : 2.5mm
- Undersize bearing value : 0.25, 0.50, 0.75, 1.00

Bearing size	Journal outer diameter (mm{in.})
Standard	79.940 - 79.960 {3.1472 - 3.1480}
0.25.00US	79.690 - 79.710 {3.1374 - 3.1382}
0.50US	79.440 - 79.460 {3.1276 - 3.1283}
0.75US	79.190 - 79.210 {3.1177 - 3.1185}
1.00US	78.940 - 78.960 {3.1079 - 3.1087}

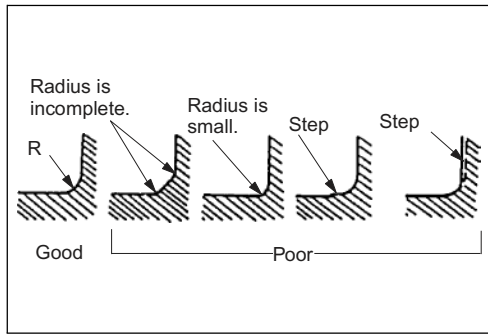

SAPH300020900104

- (5) Dimension of fillet "R"

Crank pin

2.5 to 3.0mm {0.0984 to 0.1181 in.}

Journal

2.5 to 3.0mm {0.0984 to 0.1181 in.}

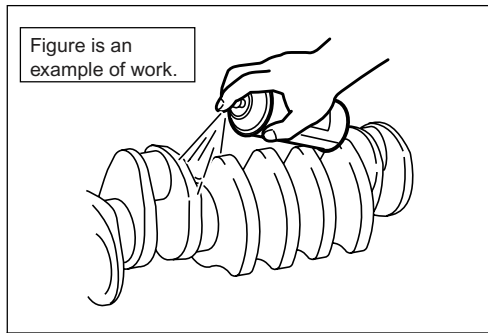

SAPH300020900105

5. Inspection of crack and damage on crankshaft and of oil hole

- (1) Check for crack or damage using dye penetrant. If a faulty condition is found, replace the crankshaft.

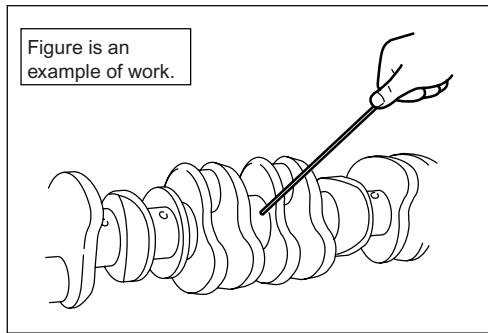

SAPH300020900106

- (2) Check for clogging of the crankshaft oil hole. If faulty condition is found, replace the crankshaft.

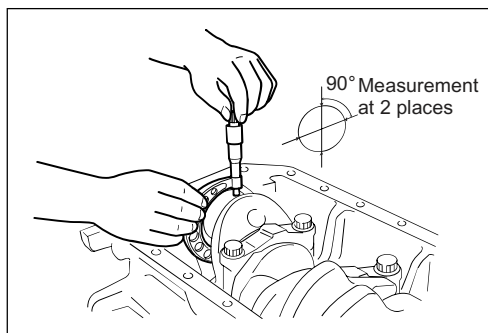

SAPH300020900107

6. Inspection of pin wear

- (1) Measure the outer diameter of the crankshaft crank pin using a micrometer. If it is faulty, grind or replace the crankshaft.

When the crankshaft is ground, use the undersize bearing.

Crank pin standard value	65
---------------------------------	-----------

Wear value (mm{in.})	Action
Eccentric wear 0.10{0.0039}	Regrind for correction.
Wear of 0.20{0.0079} or more	Regrind
Wear of 1.20{0.0472}	Replace the crankshaft.

Replacement of crankshaft pulley

JP30002090704009

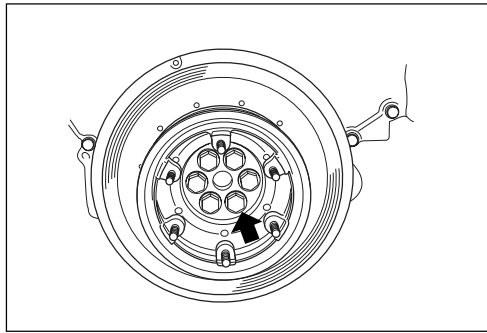

SAPH300020900108

1. Removal of crankshaft pulley

- (1) Remove bolts and remove the crankshaft pulley.

NOTICE

- Insert a large flat tip screwdriver into the flywheel gear from the flywheel housing inspection hole to prevent turning of the crankshaft.

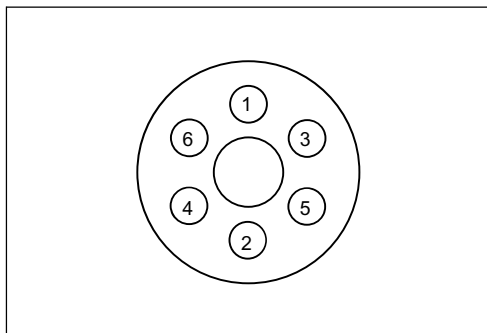

SAPH300020900109

2. Installation of crankshaft pulley

- (1) Apply engine oil to the bolt seat and the bolt thread of the crankshaft pulley mounting bolt.
- (2) Install the crankshaft pulley on the crankshaft and tighten it according to the figure.

Tightening torque : 118 N · m {1,200 kgf · cm, 87 lbf · ft}

NOTICE

- Insert a large flat tip screwdriver into the flywheel gear from the flywheel housing inspection hole to prevent turning of the crankshaft.

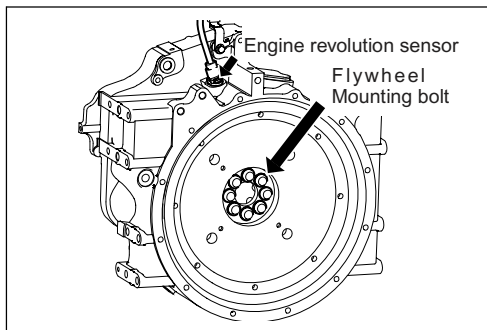

SAPH300020900110

Replacement of flywheel

JP30002090704010

1. Removal of flywheel

- (1) Remove the engine revolution sensor.
- (2) Remove bolts fixing the flywheel.

NOTICE

- Insert a large flat tip screwdriver into the flywheel gear from the flywheel housing inspection hole to prevent turning of the crankshaft.

- (3) Install a tool into the bolt hole of the crankshaft to remove the flywheel.

Guide

⚠ CAUTION

- Since the flywheel is heavy, be careful for handling.
- Do not give impact to the special tool during work.

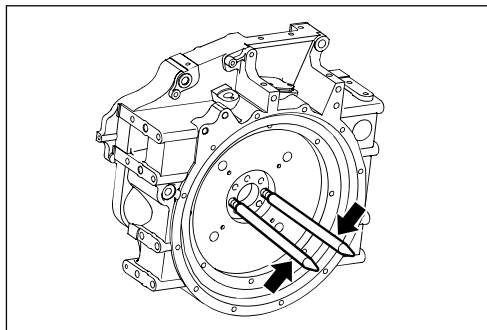

SAPH300020900111

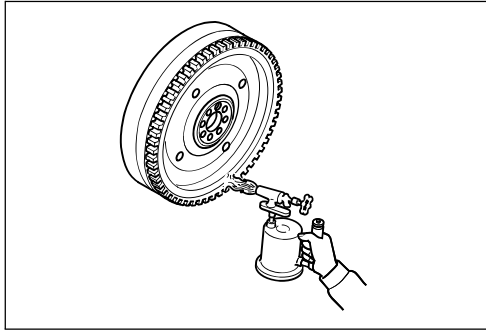

SAPH300020900112

2. Removal of ring gear

- (1) Heat the entire ring gear circumference with a burner until it is about 200 °C(392° F).

⚠ CAUTION • Do not touch the ring gear and the flywheel with bare hand while they are hot.

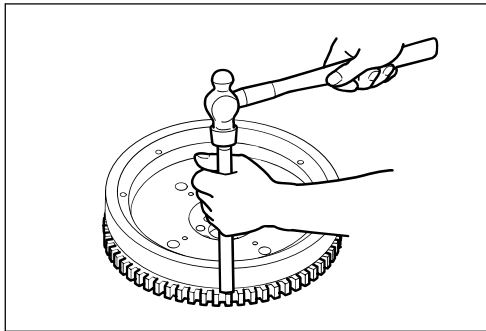

SAPH300020900113

- (2) Hit the circumference of the ring gear gently using a backing rod to remove the ring gear from the flywheel.

⚠ CAUTION • Do not touch the ring gear and the flywheel with bare hand while they are hot.

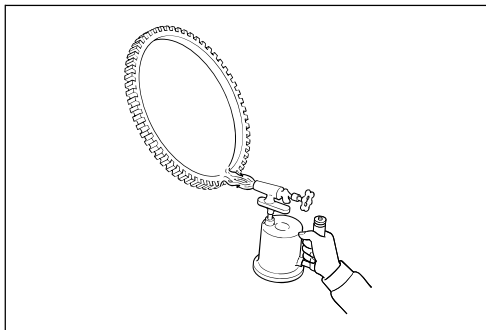

SAPH300020900114

3. Installation of ring gear

- (1) Heat the entire ring gear circumference with a burner until it is about 200 °C(392° F).

⚠ CAUTION • Do not touch the ring gear and the flywheel with bare hand while they are hot.

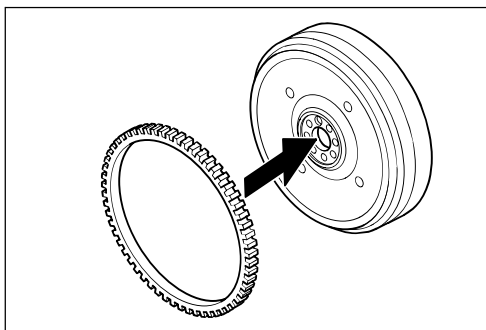

SAPH300020900115

- (2) Face the chamfered side toward the flywheel and install it on the flywheel quickly.

⚠ CAUTION • Do not touch the ring gear and the flywheel with bare hand while they are hot.

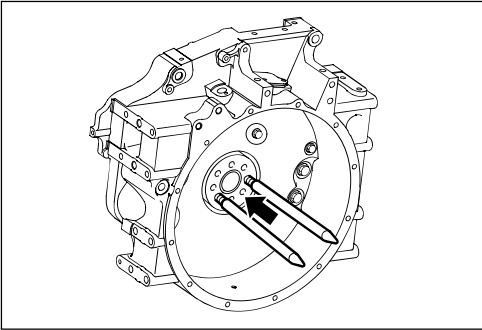

SAPH300020900116

4. Installation of flywheel

- (1) Make sure that there is no burr or dirt on the joint surface of the crankshaft and the flywheel and the screw hole.
- (2) Install the tool into the bolt hole of the crankshaft.

Guide

NOTICE • Install one special tool on the collar dowel and the other at the opposite side of the collar dowel.

- (3) Insert the flywheel until it comes in contact with the collar dowel of the crankshaft and adjust the position.

CAUTION • Since the flywheel is heavy, be careful for handling.
• Do not give impact to the special tool during work.

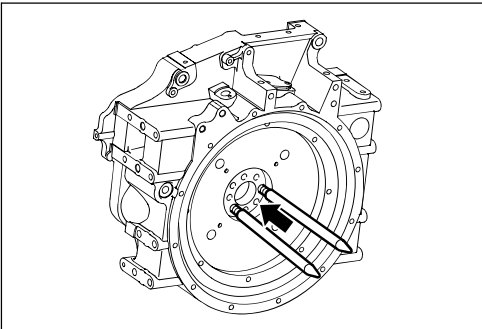

SAPH300020900117

- (4) Insert the flywheel until it comes in contact with the crankshaft.
- (5) Apply engine oil to the bolt seat and the bolt thread of the flywheel mounting bolt.

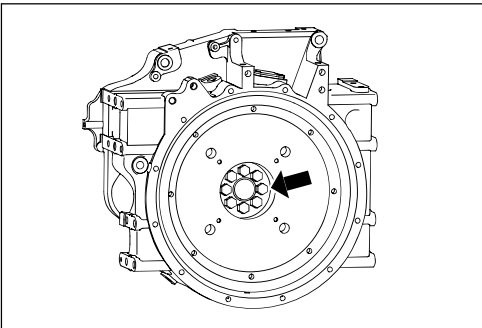

SAPH300020900118

- (6) Tighten 6 bolts by 2 to 3 threads temporarily with hand in the bolt holes without installation of the tool.
- (7) Tighten 6 bolts gradually and tighten temporarily.
- (8) Remove the tool and tighten remaining two bolts temporarily as in (6) and (7).

- (9) Tighten the flywheel according to the order in the figure.

Tightening torque : 186 N · m {1,900 kgf · cm, 137 lbf · ft}

NOTICE • Insert a large flat tip screwdriver into the flywheel gear from the flywheel housing inspection hole to prevent turning of the crankshaft.

- (10) Loosen all bolts.
- (11) Tighten the bolts again.

Tightening torque : 186 N · m {1,900 kgf · cm, 137 lbf · ft}

- (12) Install the engine revolution sensor.

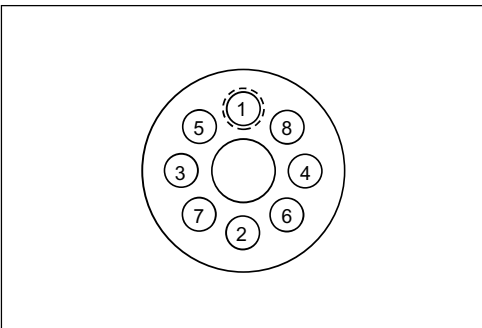

SAPH300020900119

Camshaft and Idle Gear

Part layout

JP30002090402005

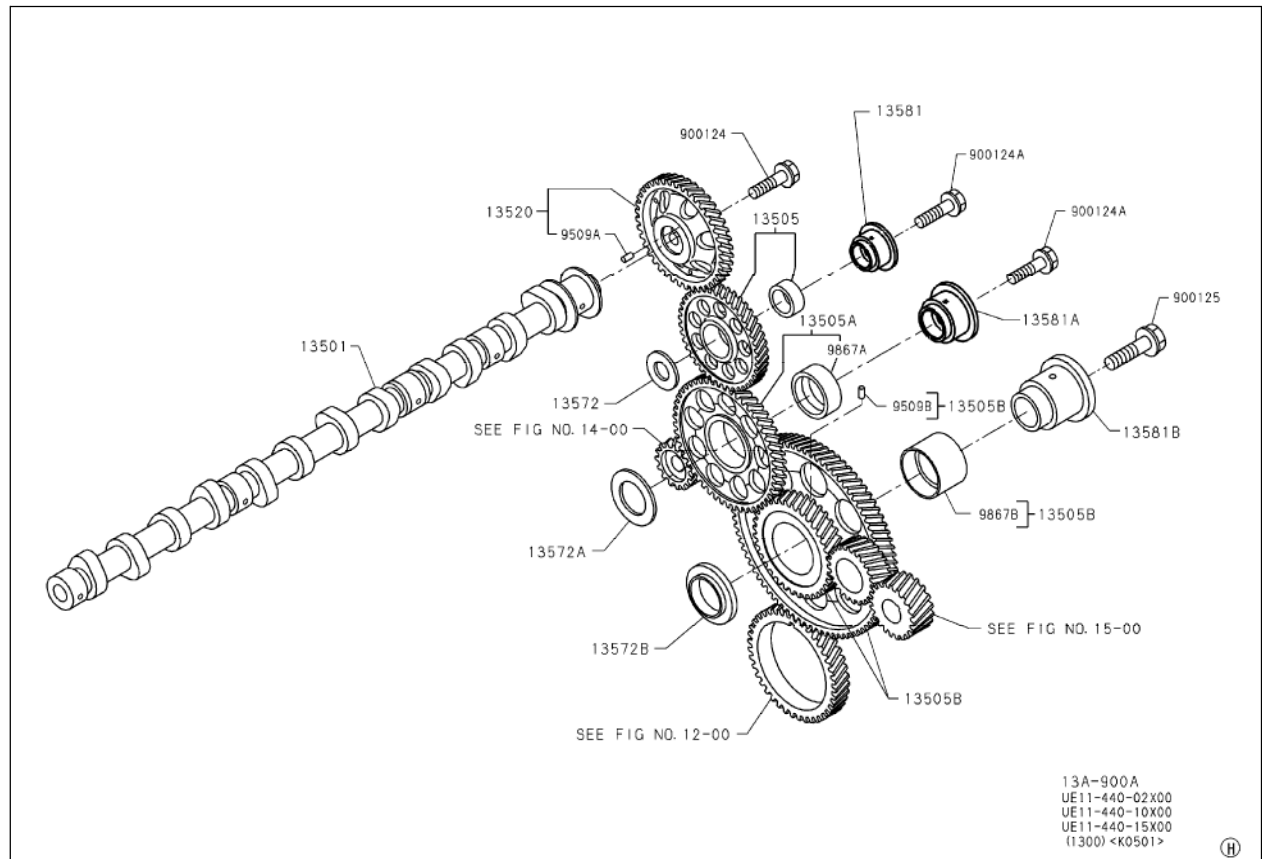

SAPH300020900120

13501	Camshaft assembly	13572A	Thrust plate
13505	Cam idle gear	13572B	Thrust plate
13505A	Sub-idle gear	13581	Idle gear shaft
13505B	Main idle gear	13581A	Idle gear shaft
13520	Camshaft gear	13581B	Idle gear shaft
13572	Thrust plate		

Tightening torque

900124	59N·m {600kgf·cm, 44lbf·ft}+90°	900125	172N·m {1,750 kgf·cm, 127lbf·ft}
900124A	108N·m {1,100 kgf·cm, 80lbf·ft}		

Removal of camshaft

JP30002090702006

1. Loosen mounting bolts of the camshaft bearing cap gradually (1/4 turn for each) and remove the camshaft.

NOTICE

- Refer to the following for installation of the camshaft.
"Reference : Installation of camshaft, Camshaft and idle gear, Engine mechanical".

Disassembly of camshaft

JP30002090702007

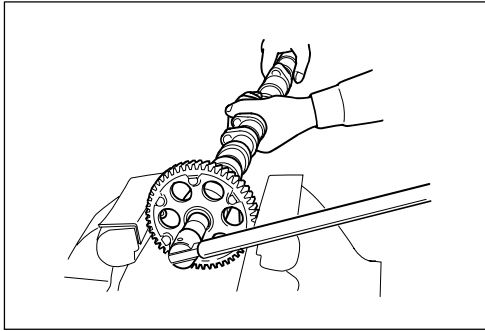

SAPH300020900121

1. Disassembly of camshaft

- (1) Fix the camshaft gear using a vice to disassemble the camshaft.

CAUTION • Prevent faulty conditions on the gear such as deformation, impact, scratch, etc.

NOTICE • Refer to the following for inspection and disassembly of the camshaft.
 "Reference : Inspection of camshaft, Camshaft and idle gear, Engine mechanical".
 "Reference : Assembly of camshaft, Camshaft and idle gear, Engine mechanical".

Inspection of camshaft and camshaft bearing

JP30002090702008

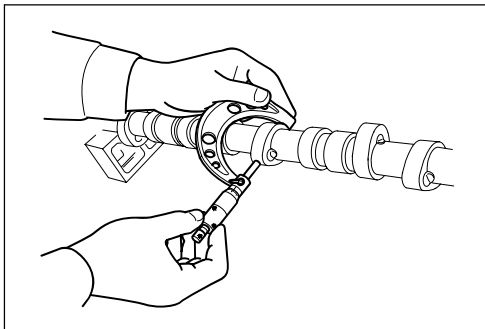

SAPH300020900122

1. Inspection of cam height on camshaft

- (1) Measure the cam height using a micrometer. If it is beyond the service limit, replace the camshaft.

		Standard value (mm{in.})	Service limit (mm{in.})
Cam height	IN	50.046{1.9703}	49.966{1.9672}
	EX	52.739{2.0763}	52.659{2.0732}
Cam lift	IN	8.046{0.3168}	(7.966{0.3136})
	EX	10.739{0.4228}	(10.659{0.4196})

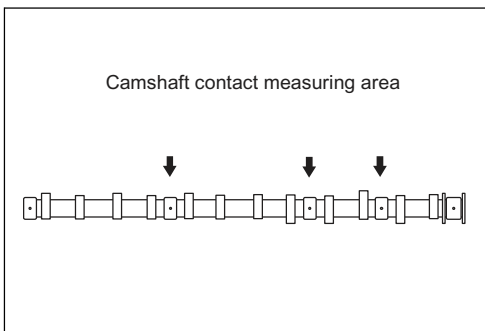

SAPH300020900123

2. Inspection of camshaft runout

- (1) Put the journal at both ends of the camshaft on the V block.
- (2) Put a dial gauge to each journal of the camshaft and measure runout of the camshaft. If it is beyond the service limit, replace the camshaft.

Standard value (mm{in.})	Service limit (mm{in.})
0.04{0.0016}	0.1{0.0039}

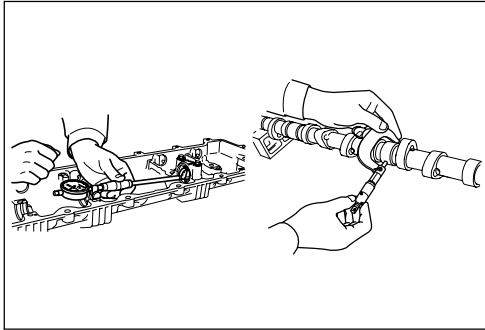

SAPH300020900124

3. Inspection of camshaft bearing oil clearance

- (1) Measure the outer diameter of the camshaft journal using a micrometer.

Standard value (mm{in.})	Service limit (mm{in.})
40{1.5748}	39.85{1.5689}

- (2) Measure the camshaft bearing inner diameter using a cylinder gauge.

Standard value (mm{in.})	Service limit (mm{in.})
40{1.5748}	40.15{1.5807}

- (3) Calculate the difference of the camshaft journal bearing inner diameter. If it is beyond the standard value, replace the camshaft or the camshaft bearing.

Standard value (mm{in.})	0.020 - 0.063 {0.0008 - 0.0025}
--------------------------	------------------------------------

Assembly of camshaft

JP30002090702009

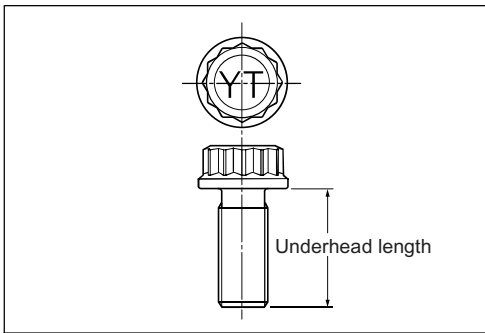

SAPH300020900125

1. Measure the camshaft mounting bolt using a vernier calipers. If it is out of the service limit, replace it with a new one.

Service limit (mm{in.})	30.5{1.2008}
-------------------------	--------------

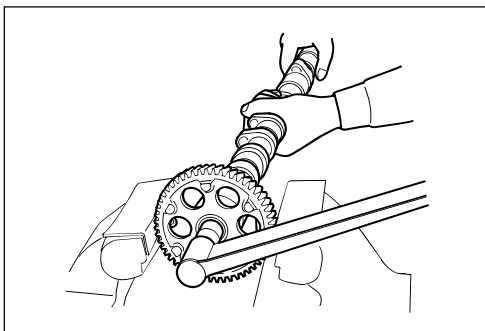

SAPH300020900126

2. Fix the camshaft gear using a vice. Apply engine oil to the seat and the bolt thread of the camshaft gear mounting bolt.

3. Set the dowel pin to the camshaft and the camshaft gear and tighten the camshaft gear mounting bolt.

Tightening torque : 59 N · m {600 kgf · cm, 44 lbf · ft}

4. Retighten 90 deg (1/4 turn).

- ⚠ CAUTION**
- If it is excessively retightened, do not loosen it.
 - Prevent faulty conditions on the gear such as deformation, impact, scratch, etc.

Installation of camshaft

JP30002090702010

1. Align the No. 1 cylinder to the compression top dead center.

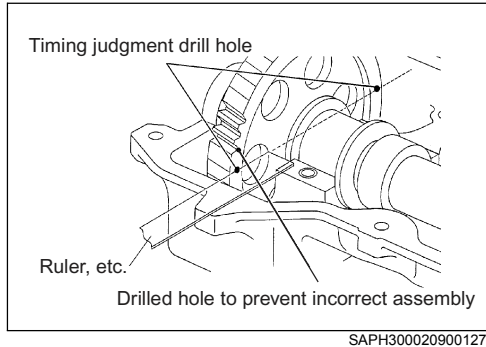

2. Installation of camshaft

- (1) Place the camshaft so that two holes at 180 degrees from the three drilled holes of the camshaft gear may be horizontal to the upper surface of the camshaft housing.

CAUTION • Place a transparent plastic ruler or an edged ruler on the upper surface of the camshaft housing and the side of the camshaft gear. Make sure that the position of the foolproof drilled hole is below the ruler.

- (2) Adjust the direction and the position for installation of the camshaft bearing cap.

Tightening torque : 31 N·m {320 kgf·cm, 23 lbf·ft}

CAUTION • In the camshaft bearing cap, the triangle mark faces forward. The order of stamps is 1, 2, 3, 4 and 5 from the front.

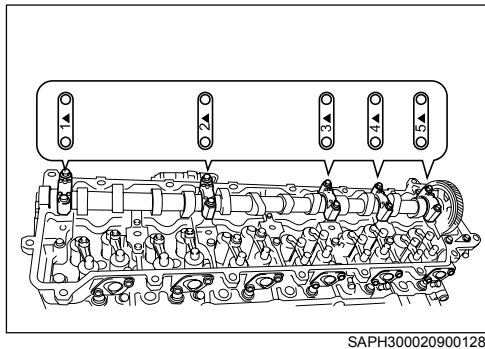

Gear train layout

JP30002090402006

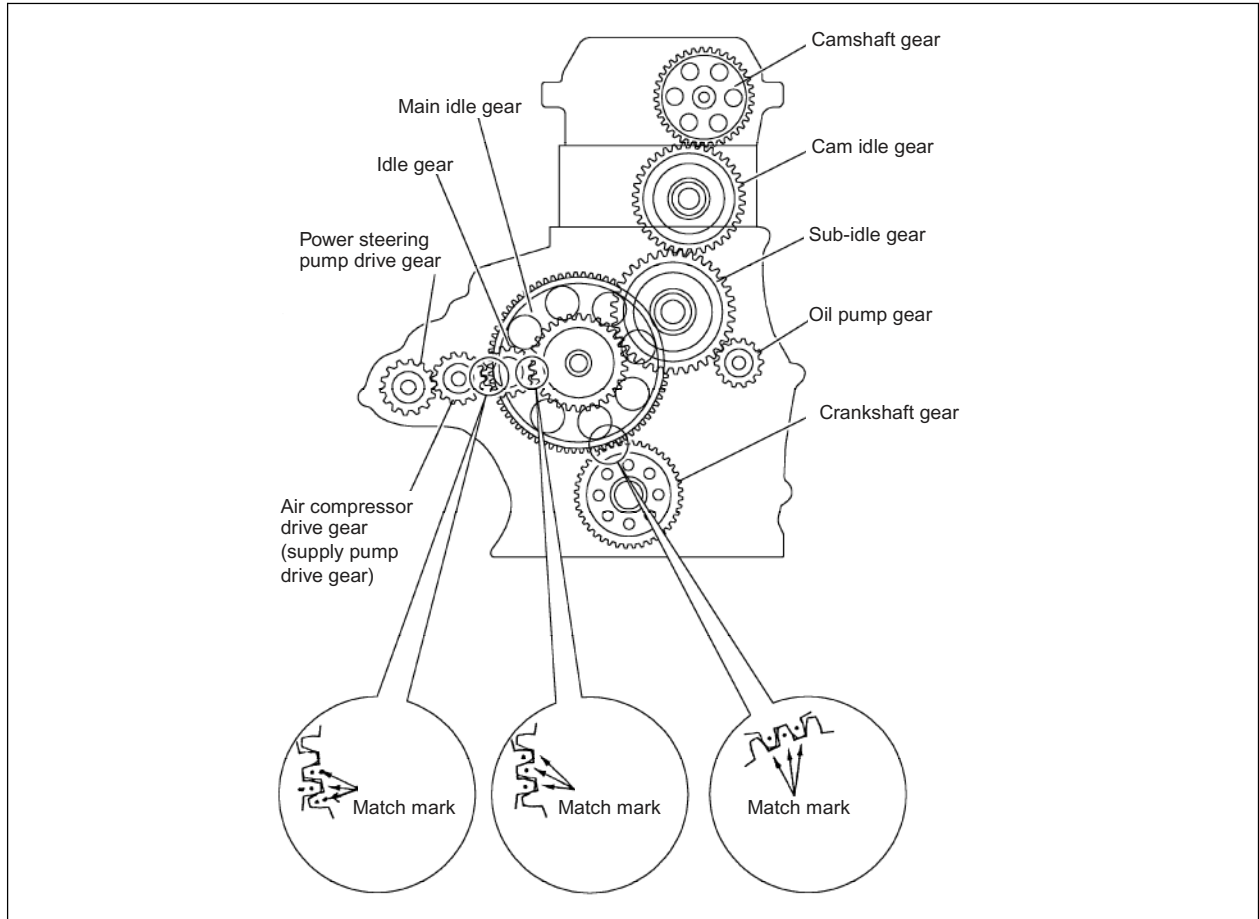

SAPH300020900129

Removal of timing gear

JP30002090702011

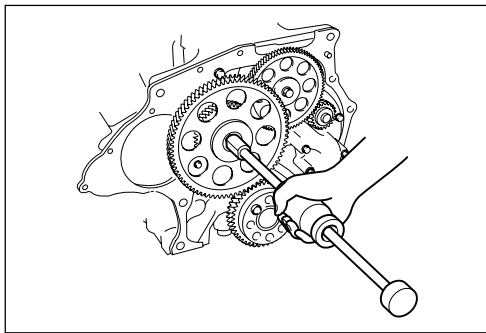

SAPH300020900130

1. Removal of main idle gear

- (1) Remove the idle gear shaft mounting bolt and pull out the main idle gear assembly using a special tool.

**Special tool : 380100035 Sliding hammer
380100036 Sliding hammer**

- (2) Remove the idle gear thrust plate.
- (3) Remove the idle gear shaft from the main idle gear.

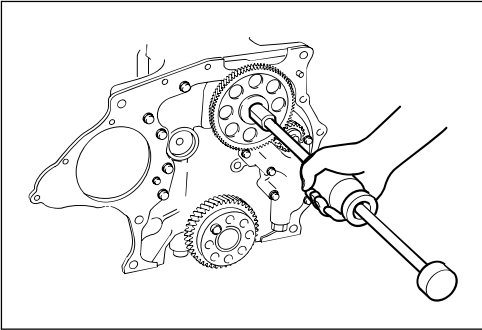

SAPH300020900131

2. Removal of sub-idle gear

- (1) Remove the idle gear shaft mounting bolt and the idle gear thrust plate and pull out the sub-idle gear assembly using a special tool.

Special tool : 380100035 Sliding hammer
380100036 Sliding hammer

- (2) Remove the idle gear thrust plate.
- (3) Remove the idle gear shaft from the sub-idle gear.

NOTICE

- Refer to the following for inspection and assembly of the timing gear.
"Reference : Inspection of timing gear component, Camshaft and idle gear, Engine mechanical"
"Reference : Assembly of timing gear, Camshaft and idle gear, Engine mechanical"

Inspection of timing gear components

JP30002090702012

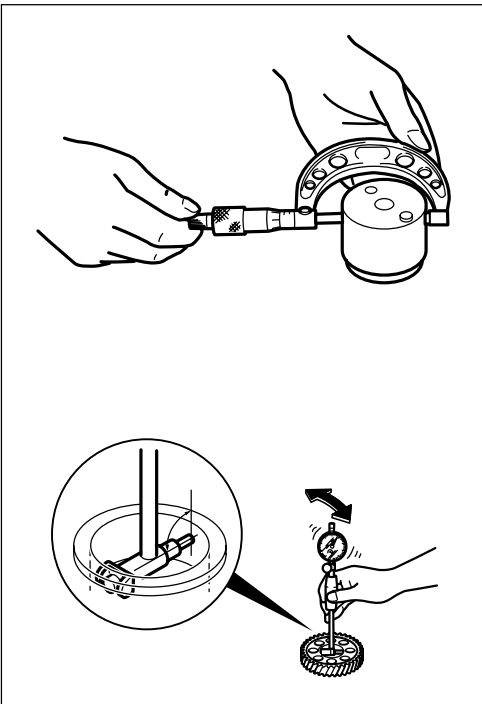

SAPH300020900132

1. Inspection of clearance between idle gear shaft and idle gear bushing

- (1) Measure the idle gear shaft outer diameter using a micrometer and the idle gear bushing inner diameter using a cylinder gauge.

		Standard value (mm{in.})
Main idle gear shaft	Shaft outer diameter	57{2.2441}
	Bushing inner diameter	57{2.2441}
Sub-idle gear shaft	Shaft outer diameter	50{1.9685}
	Bushing inner diameter	50{1.9685}

- (2) Calculate the difference between the idle gear bushing inner diameter and the idle gear shaft outer diameter. If it is beyond the service limit, replace the idle gear shaft and the idle gear.

	Standard value (mm{in.})	Service limit (mm{in.})
Main idle gear shaft	0.030 - 0.090 {0.0012 - 0.0035}	0.20{0.0079}
Sub-idle gear shaft	0.025 - 0.075 {0.0010 - 0.030}	0.20{0.0079}

Installation of timing gear

JP30002090702013

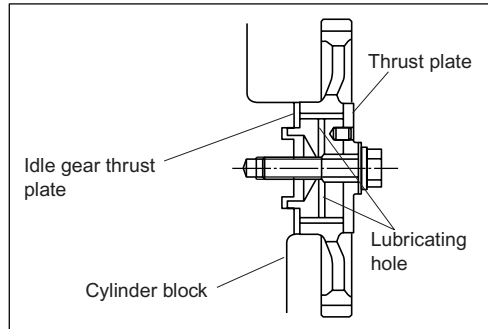

SAPH300020900133

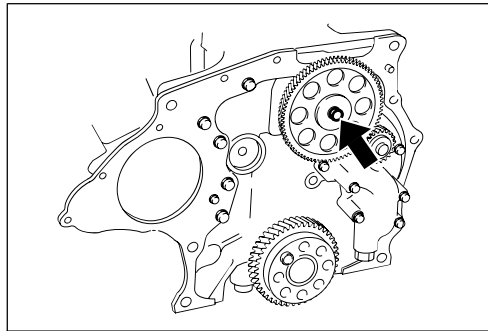

SAPH300020900134

1. Installation of sub-idle gear

- (1) Install the idle gear shaft on the sub-idle gear.
- (2) Install the idle gear thrust plate.
- (3) Provide the lubricating hole of the idle gear shaft in the vertical direction.

- (4) Install the idle gear thrust plate on the idle gear shaft.
- (5) Apply engine oil to the bolt seat and the bolt thread of the idle gear shaft mounting bolt.
- (6) Install the idle gear shaft mounting bolt.

Tightening torque : 108 N · m {1,100 kgf · cm, 80 lbf · ft}

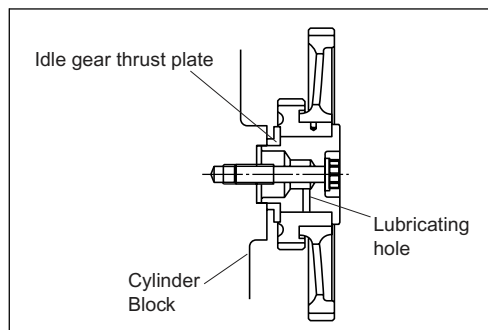

SAPH300020900135

2. Installation of main idle gear

- (1) Install the idle gear shaft on the main idle gear.
- (2) Install the idle gear thrust plate.

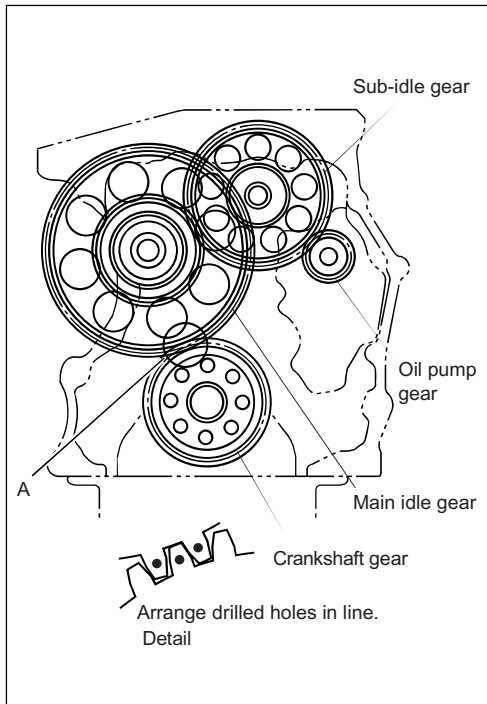

- (3) Face the lubricating hole of the idle gear shaft toward the oil pan (downward). Install A in the figure by adjusting the timing of the crankshaft gear and the main idle gear as in the detailed drawing.

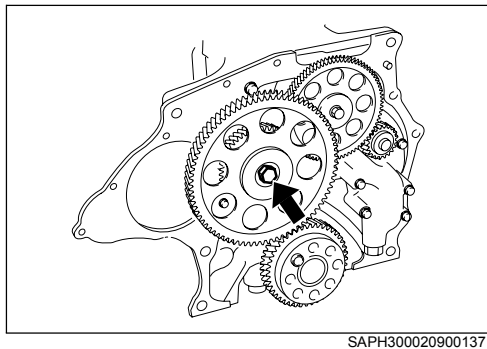

- (4) Apply engine oil to the bolt seat and the bolt thread of the idle gear shaft mounting bolt.
- (5) Install the idle gear shaft mounting bolt.
Tightening torque : 172 N · m {1,750 kgf · cm, 127 lbf · ft}
- (6) Measure backlash and end play of each idle gear. Make sure that it is within the standard value.

Overhaul of sub-idle gear (bearing case side)

JP30002090702014

1. Removal of bearing case assembly

- (1) Remove the supply pump drive.
"Reference : Replacement, Supply pump".
- (2) Remove 5 bolts and remove the bearing case assembly.

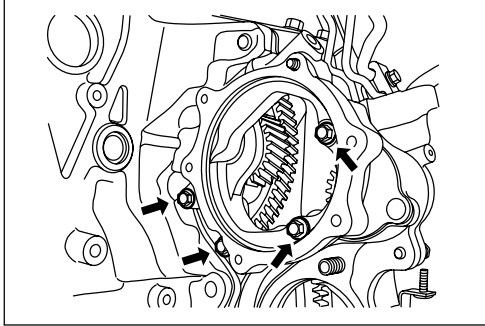

SAPH300020900138

⚠ CAUTION • One bolt is tightened from the timing gear case.

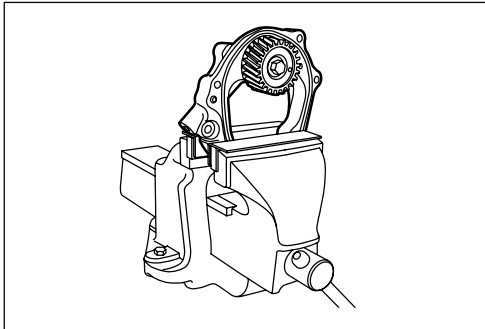

SAPH300020900139

- (3) Fix the bearing case with a vice.

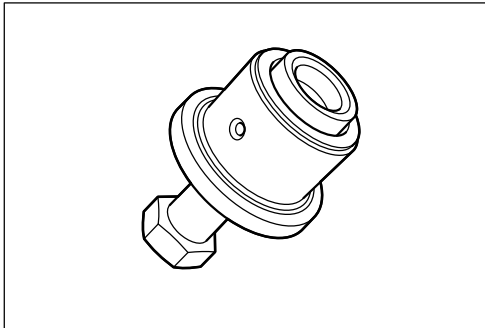

SAPH300020900140

- (4) Remove the sub-idle gear shaft mounting bolt and pull out the idle gear shaft using a sliding hammer.

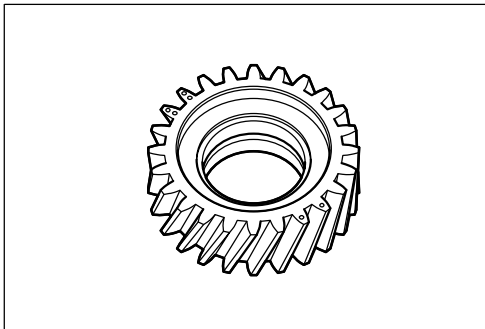

SAPH300020900141

- (5) Remove the sub-idle gear.
- (6) Remove the idle gear thrust plate.

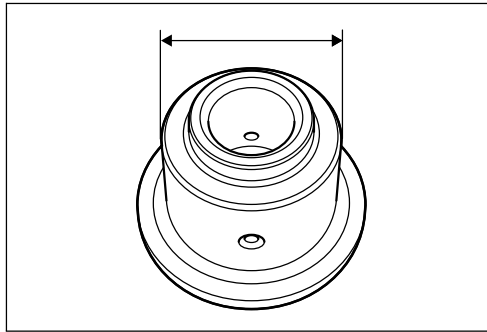

SAPH300020900142

2. Inspection of clearance between sub-idle gear shaft and sub-idle gear bushing

(1) Measure the outer diameter of the idle gear shaft.

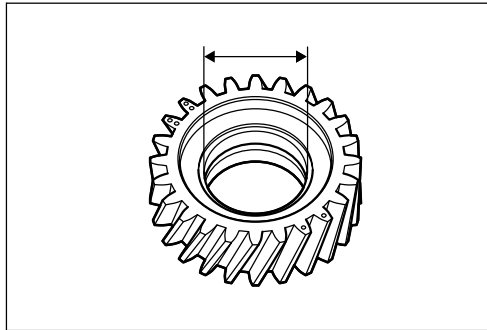

SAPH300020900143

(2) Measure the inner diameter of the sub-idle gear.

(3) Calculate the clearance. If it is beyond the standard value, replace the shaft and the bushing.

Standard value (mm{in.})	0.025 - 0.075 {0.0010 - 0.030}
---------------------------------	---

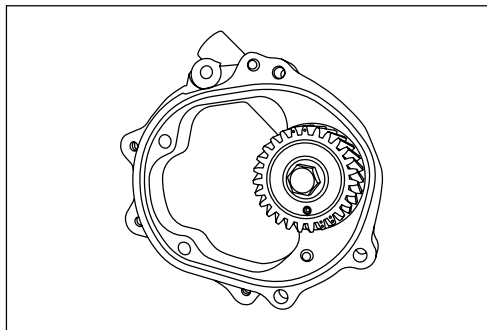

SAPH300020900144

3. Installation of bearing case assembly

(1) Install the idle gear thrust plate.

(2) Install the gear shaft on the sub-idle gear.

(3) Face the lubricating hole of the gear shaft downward and install it on the bearing case.

(4) Install the sub-idle gear shaft mounting bolt.

Tightening torque : 108 N · m {1,100 kgf · cm, 80 lbf · ft}

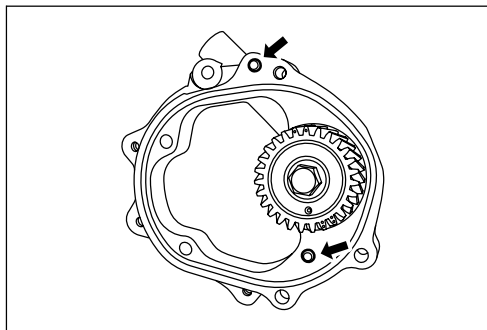

SAPH300020900145

(5) Align two pins of the bearing case assembly with the concave area of the flywheel housing for installation.

Tightening torque : 28.5 N · m {290 kgf · cm, 21 lbf · ft}

⚠ CAUTION • Be careful for fall of the O-ring

Inspection of installation status for each gear

JP30002090703003

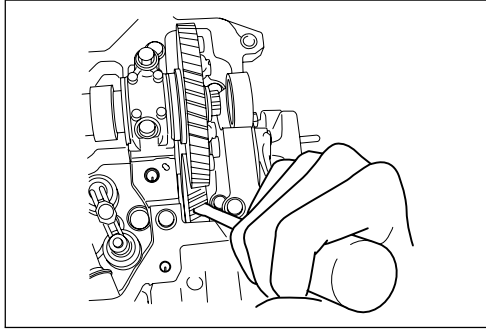

SAPH300020900146

1. Inspection of backlash between camshaft gear and cam idle gear

- (1) Insert a large flat tip screwdriver into the cam idle gear from the side of the camshaft gear of the camshaft housing to prevent turning of the cam idle gear.

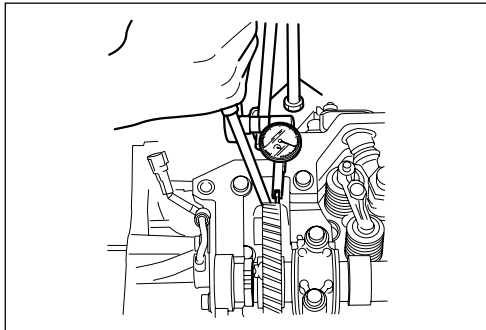

SAPH300020900147

- (2) Measure backlash between the camshaft gear and the cam idle gear using a dial gauge. If it is beyond the service limit, replace each gear.

Standard value (mm{in.})	Service limit (mm{in.})
0.030 - 0.253 {0.0012 - 0.0100}	0.30{0.0118}

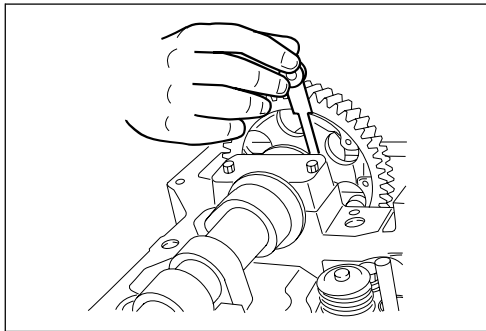

SAPH300020900148

2. Inspection of camshaft end play

- (1) Measure the end play of the camshaft using a thickness gauge. If it is beyond the standard value, replace the camshaft.

Standard value (mm)	0.100 - 0.178 {0.0039 - 0.0070}

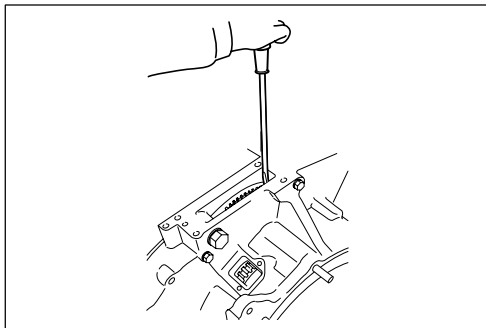

SAPH300020900149

3. Inspection of backlash between main idle gear and sub-idle gear

- (1) Remove the supply pump drive at the bearing case.
"Reference : Replacement, Supply pump".
- (2) Insert a large flat tip screwdriver into the main idle gear from the timing gear dust cover of the flywheel housing to prevent turning of the main idle gear.

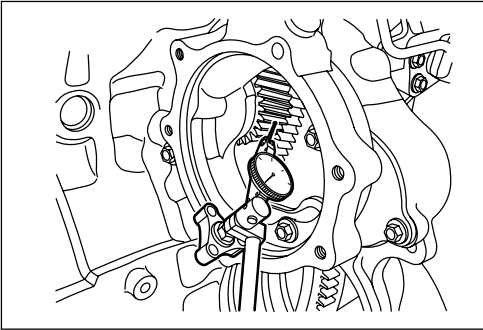

SAPH300020900150

- (3) Measure backlash between the main idle gear and the sub-idle gear using a dial gauge and a magnet stand. If it is beyond the service limit, replace each gear.

NOTICE

- If the magnet stand is not stable, provide a steel plate for measurement using bolt holes of the cylinder block.

Standard value (mm{in.})	Service limit (mm{in.})
0.030 - 0.218 {0.0012 - 0.0086}	0.30{0.0118}

4. Inspection of backlash between sub-idle gear at bearing case and supply pump drive gear

- (1) Remove the supply pump drive.
"Reference : Replacement, Supply pump"
- (2) Remove the bearing case assembly.
- (3) Fix the supply pump drive with a vice and install the bearing case assembly.
- (4) Measure backlash between the sub-idle gear and the supply pump drive gear using a dial gauge and a magnet stand. If it is beyond the service limit, replace each gear.

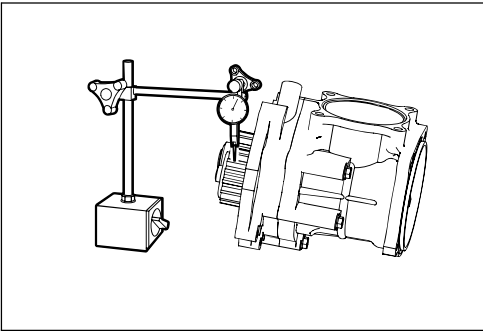

SAPH300020900151

Standard value (mm{in.})	Service limit (mm{in.})
0.020 - 0.083 {0.0008 - 0.0033}	0.10{0.0039}

5. Inspection of backlash between main idle gear and sub-idle gear

- (1) Insert a large flat tip screwdriver into the main idle gear from the timing gear dust cover of the flywheel housing to prevent turning of the main idle gear.

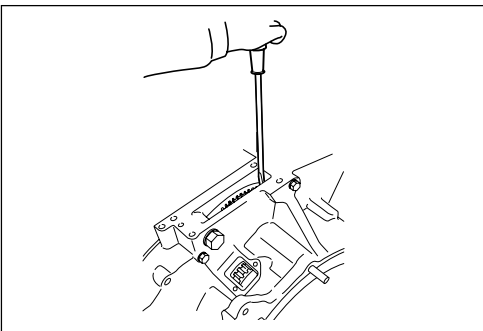

SAPH300020900152

- (2) Measure backlash between the main idle gear and the sub-idle gear using a dial gauge and a magnet stand. If it is beyond the service limit, replace each gear.

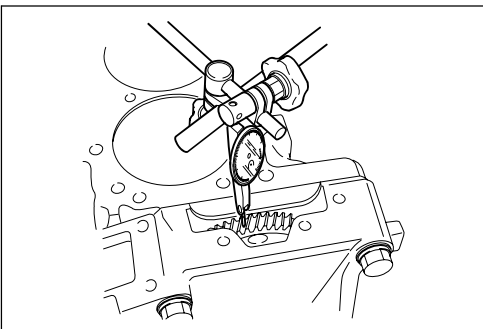

SAPH300020900153

Standard value (mm{in.})	Service limit (mm{in.})
0.030 - 0.162 {0.0012 - 0.0064}	0.30{0.0118}

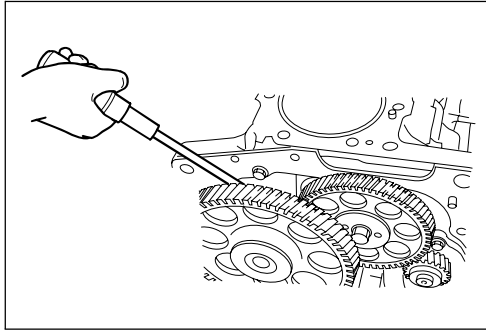

SAPH300020900154

6. Inspection of backlash between sub-idle gear at cam idle gear and oil pump gear

- (1) Insert a large flat tip screwdriver into the sub-idle gear to prevent turning of the sub-idle gear.

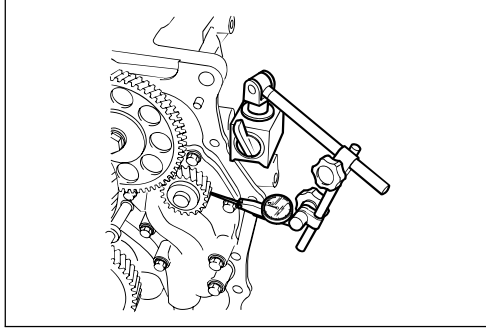

SAPH300020900155

- (2) Measure backlash between the sub-idle gear and the oil pump gear using a dial gauge and a magnet stand. If it is beyond the service limit, replace each gear.

Standard value (mm{in.})	Service limit (mm{in.})
0.030 - 0.131 {0.0012 - 0.0005}	0.30{0.0118}

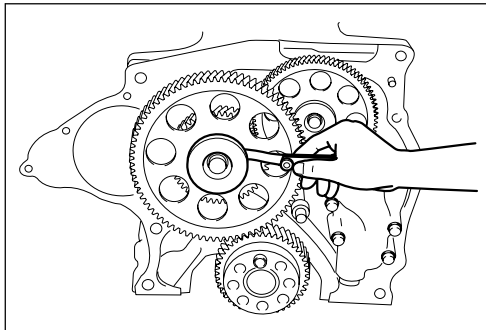

SAPH300020900156

7. Inspection of idle gear end play

- (1) Measure the end play of each gear using a thickness gauge. If it is beyond the service limit, replace each gear and shaft.

	Standard value (mm{in.})	Service limit (mm{in.})
Main idle gear	0.114 - 0.160 {0.0045 - 0.0063}	0.30{0.0118}
Sub-idle gear	0.040 - 0.095 {0.0016 - 0.0037}	0.30{0.0118}

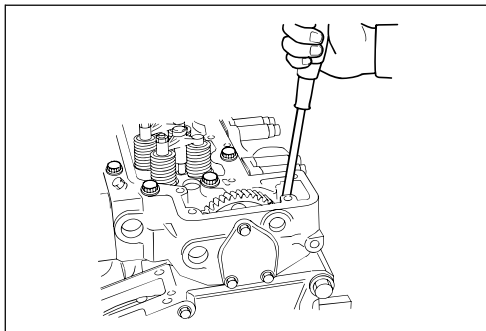

SAPH300020900157

8. Inspection of backlash between cam idle gear and sub-idle gear

- (1) Insert a large flat tip screwdriver into the sub-idle gear from the side of the cam idle gear of the cylinder head to prevent turning of the sub-idle gear.

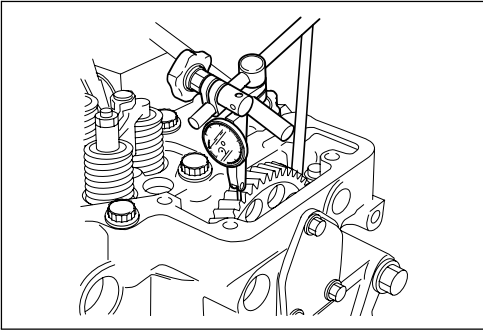

SAPH300020900158

- (2) Measure backlash between the cam idle gear and the sub-idle gear using a dial gauge. If it is beyond the service limit, replace each gear.

Standard value (mm{in.})	Service limit (mm{in.})
0.050 - 0.218 {0.0020 - 0.0086}	0.30{0.0118}

Valve System

Part layout

JP30002090402007

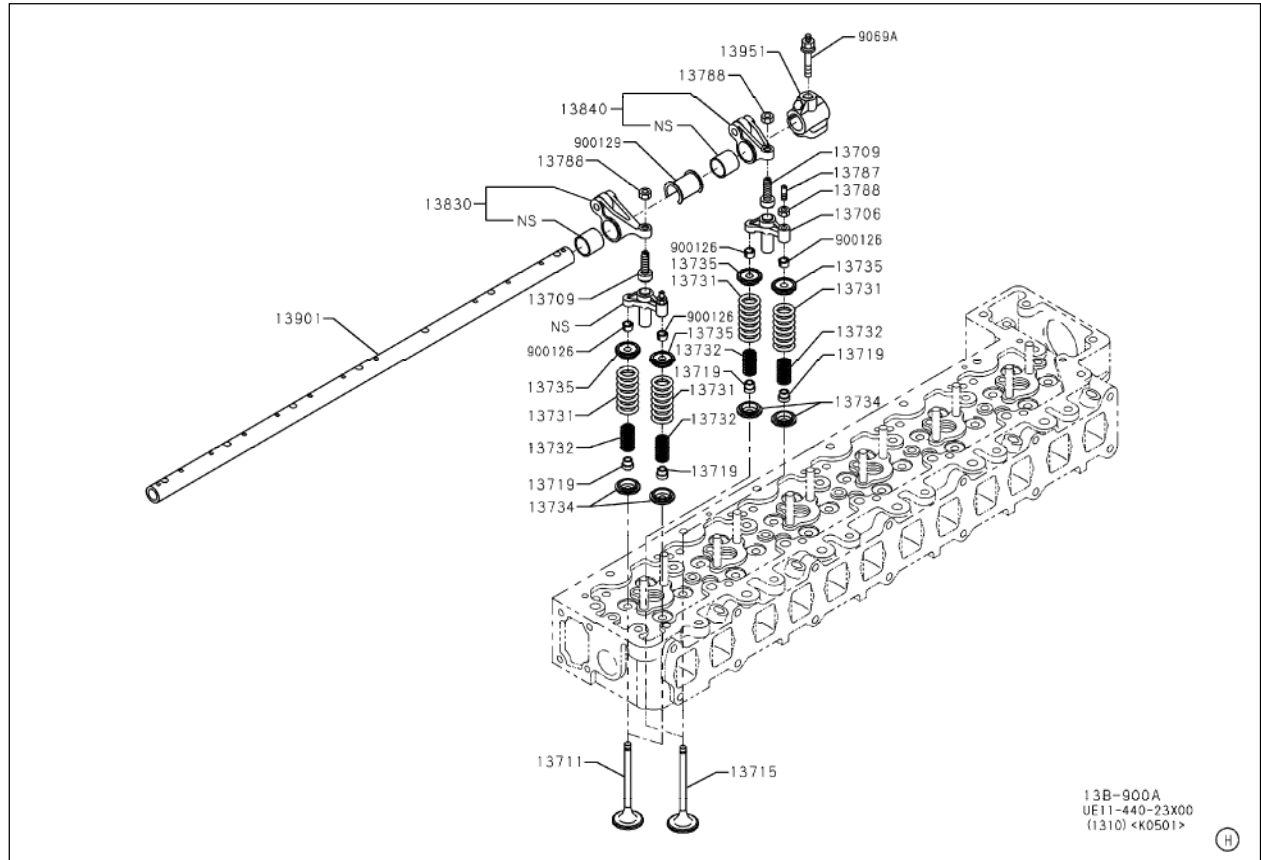

13B-900A
UE11-440-23X00
(1310) <K0501>



SAPH300020900159

13706	Crosshead assembly	13735	Valve seat upper
13709	Adjusting screw	13830	Rocker arm intake
13711	Intake valve	13840	Rocker arm (exhaust)
13715	Exhaust valve	13901	Rocker shaft
13731	Outer spring	13951	Rocker support
13732	Inner spring	900126	Valve stem seal*
13734	Valve seat lower		

*Parts not to be reused.

Tightening torque

13788	25N·m {250 kgf·cm, 18lbf·ft}
-------	------------------------------

Overhaul of valve system

JP30002090702015

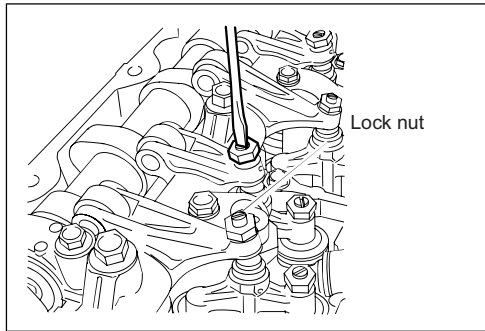

SAPH300020900160

1. Removal of rocker arm and rocker arm shaft

- (1) Loosen the lock nut and turn the adjusting screw completely.

CAUTION • Removal without turning the adjusting screw may bend the rocker arm shaft.

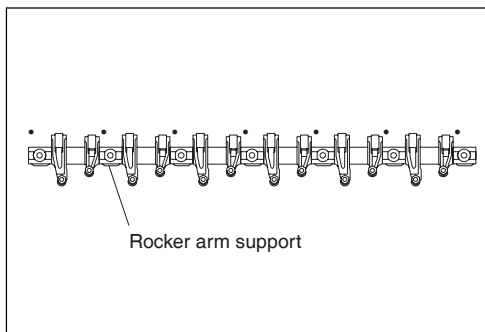

SAPH300020900161

- (2) Loosen the rocker arm support bolts gradually from the center and remove the rocker arm and the rocker arm shaft.

• • • • •

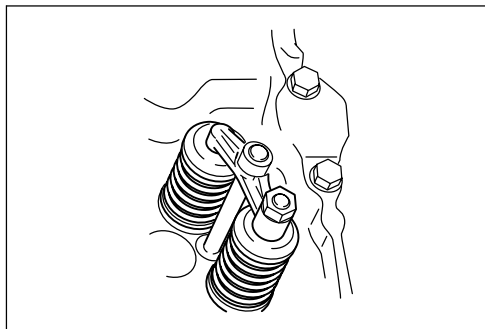

SAPH300020900162

2. Installation of rocker arm and rocker arm shaft

- (1) Make sure that the crosshead is correctly (covering) on each valve.

CAUTION • To ensure that the crosshead is correctly on the valve, move the crosshead to left or right with hand and confirm "clicking" sound.

• If the crosshead is offset from the valve in assembly, the upper seat may be pressed, resulting in fall of the valve.

- (2) Make sure that the rocker arm is correctly assembled into the rocker arm shaft.

- (3) Turn the adjusting screw at the end of the rocker arm completely.

NOTICE • Bundling the rocker arm with a rubber band eases installation.

CAUTION • After installation, apply engine oil to the cam.

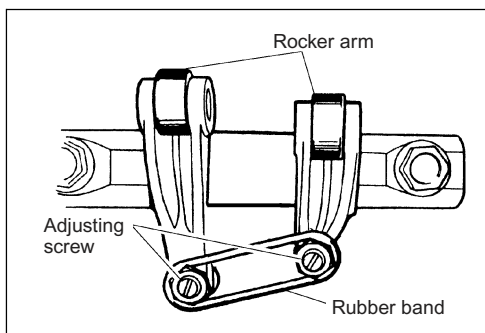

SAPH300020900163

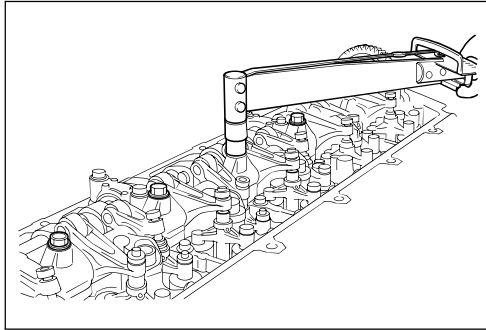

SAPH300020900164

- (4) Place the rocker arm and the rocker arm shaft on the camshaft housing and make sure that the rocker arm is correctly on the crosshead. Tighten the rocker arm support bolts gradually several times.

Tightening torque : 59 N · m {600 kgf · cm, 44 lbf · ft}

- ⚠ CAUTION**
- After tightening, make sure that the rocker arm moves smoothly.
 - Make sure that there is no undue force on the injection pipe oil seal.
(Otherwise, oil leak or poor assembly of injection pipe may occur.)

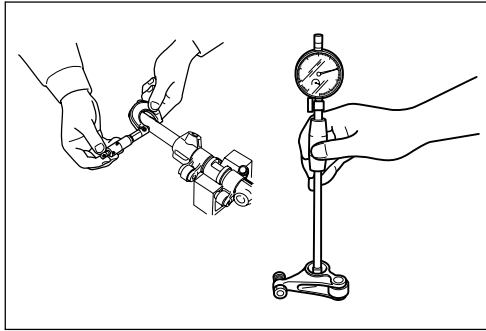

SAPH300020900165

3. Inspection of rocker arm oil clearance

- (1) Measure the outer diameter of the rocker shaft using a micrometer.

Standard value (mm{in.})	Service limit (mm{in.})
22{0.8661}	21.92{0.8630}

- (2) Measure the rocker arm bushing inner diameter using a cylinder gauge.

Standard value (mm{in.})	Service limit (mm{in.})
22{0.8661}	20.08{0.7905}

- (3) Calculate the difference between the outer diameter of the rocker shaft and the inner diameter of the rocker arm bushing. If it is beyond the standard value, replace the rocker shaft or the rocker arm bushing.

Standard value (mm{in.})	Service limit (mm{in.})
0.03 - 0.101 {0.0012 - 0.0039}	0.15{0.0059}

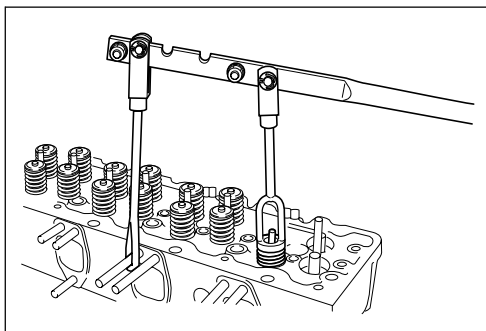

SAPH300020900166

4. Removal of valve spring

- (1) Compress the valve spring using a tool and remove the valve spring retainer.

Valve spring press

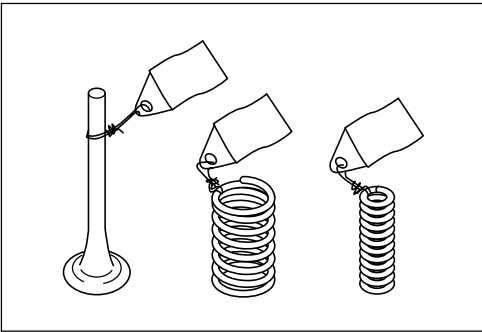

SAPH300020900167

- (2) Remove the intake and exhaust valves.

CAUTION • Attach a tag with the applicable cylinder number to the valve so that combinations of the valve and the cylinder head may not be mixed.

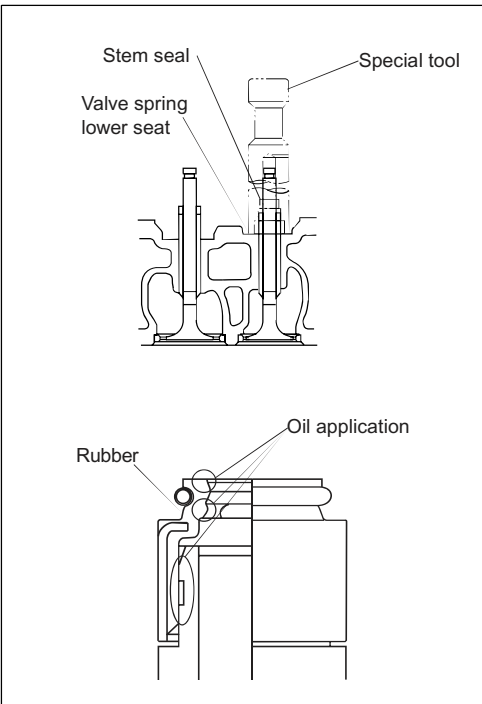

SAPH300020900168

5. Replacement of valve stem seal

- (1) After removing the valve stem seal, assemble the valve spring lower seat. Apply engine oil to the lip and the inner surface of the stem seal. Strike the valve guide using a special tool until the special tool comes in contact with the valve spring lower seat

Special tool : 308100033 Bar

CAUTION • After assembly of the stem seal, make sure that there is no deformation, crack or inclination of the rubber.

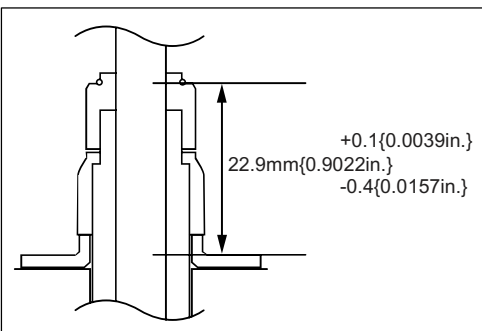

SAPH300020900169

- (2) After striking, check the height.

Standard value (mm{in.})	22.5 - 23.0 {0.8858 - 0.9055}
---------------------------------	--

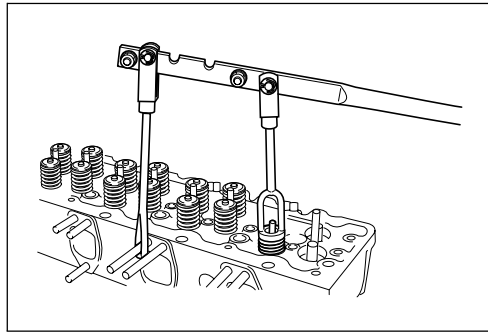

SAPH300020900170

6. Installation of valve spring

- (1) Install the valve spring upper seat on the valve spring.
- (2) Compress the valve spring using a tool and install the valve spring retainer.

Valve spring press

- CAUTION**
- Apply engine oil to the contact surface of each part before assembly.
 - Be sure to assemble each valve at the original cylinder position.
 - When the valve spring is compressed, avoid contact of the valve spring upper seat with the valve stem seal.
 - Since the valve spring has equal spacing, vertical direction is not specified for assembly.
 - Check for scratch on the valve stem seal when the valve is reused.

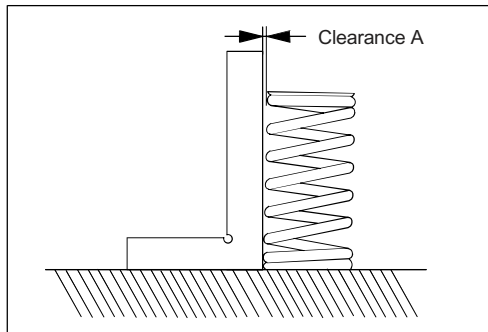

SAPH300020900171

7. Inspection of valve spring

- (1) Measure squareness of the valve spring using a square or a thickness gauge. If it is beyond the service limit (clearance A), replace the valve spring.

Clearance A (mm{in.})	2.0{0.0787}
------------------------------	--------------------

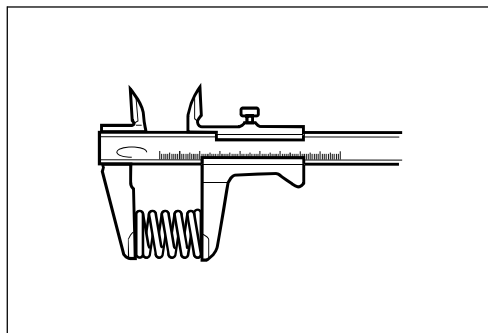

SAPH300020900172

- (2) Measure the free length of the valve spring using a vernier calipers. If it is out of the service limit, replace the valve spring.

	Standard value (mm{in.})	Service limit (mm{in.})
Inner valve spring	(64.6{2.5433})	61.6{2.4252}
Outer valve spring	(75.7{2.9803})	72.7{2.8622}

The value in [] is the reference value.

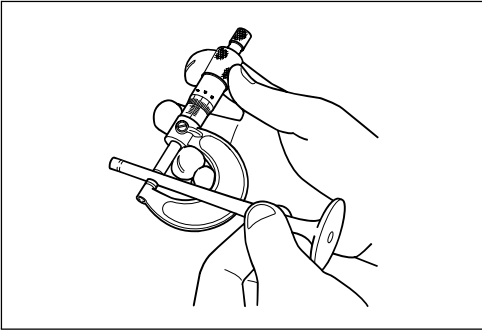

SAPH300020900173

8. Inspection of oil clearance between valve guide and valve stem

- (1) Measure the outer diameter of the valve stem using a micrometer.

	Standard value (mm{in.})
Intake valve stem	7{0.2756}
Exhaust valve stem	7{0.2756}

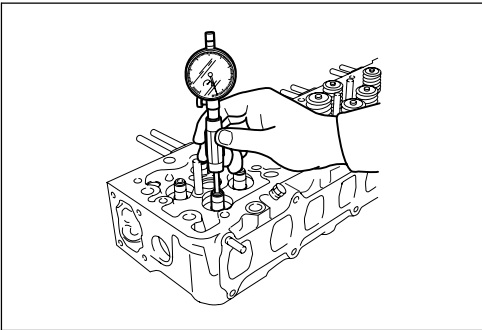

SAPH300020900174

- (2) Measure the valve guide inner diameter using a cylinder gauge.

	Standard value (mm{in.})
Intake valve guide	7{0.2756}
Exhaust valve guide	7{0.2756}

- (3) Calculate the difference between the valve system outer diameter and the valve system inner diameter. If it is beyond the standard value, replace the valve or the valve guide.

	Standard value (mm{in.})
Intake valve oil clearance	0.023 - 0.058 {0.0009 - 0.0023}
Exhaust valve oil clearance	0.050 - 0.083 {0.0020 - 0.0033}

Adjustment of valve clearance

JP30002090706001

1. Precautions before adjustment

- ⚠ **CAUTION** • Before adjustment, make sure that bolts of the cylinder head, rocker arm support, nozzle clamp, camshaft housing and camshaft bearing cap are tightened to the specified torque.

2. Adjustment of valve clearance

- (1) Make sure that there is no dirt between the crosshead and the valve stem
- (2) Turn the crankshaft in the forward direction and adjust the cylinder to the compression top dead center.

- ⚠ **CAUTION** • Make sure that there is a roller on the cam base circle.

- (3) Loosen the adjusting screw and the lock nut of the crosshead completely.

- ⚠ **CAUTION** • Provide the adjusting screw protrusion of 10 mm or more from the top surface of the crosshead. If the adjusting screw is not completely separated from the valve stem, correct adjustment is not allowed.

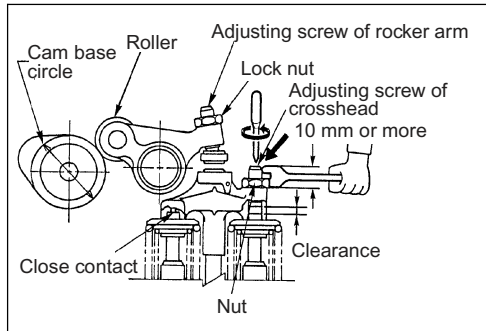

SAPH300020900175

- (4) Insert a thickness gauge between the rocker arm and the crosshead and adjust the clearance with the adjusting screw of the rocker arm. Tighten the lock nut.

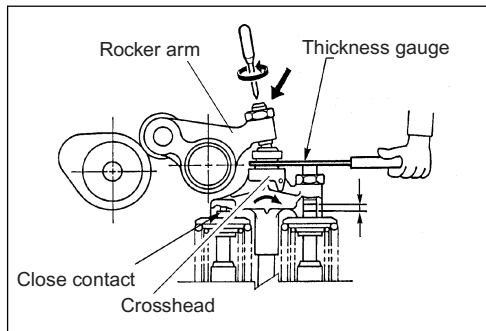

SAPH300020900176

Standard value (cold engine)	IN	0.30mm{0.0118 in.}
	EX	0.45mm{0.0177 in.}

Tightening torque : 25 N · m {250 kgf · cm, 18 lbf · ft}

- (5) Loosen the adjusting screw of the crosshead with the thickness gauge inserted. Make sure that feel on the thickness gauge is not lighter.

- ⚠ **CAUTION** • If it becomes lighter, make adjustments again from the beginning.

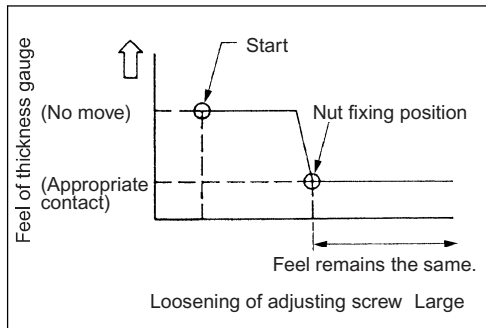

SAPH300020900177

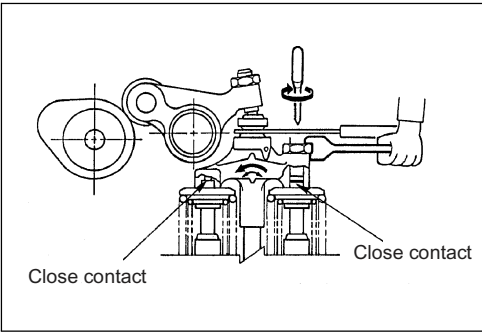

SAPH300020900178

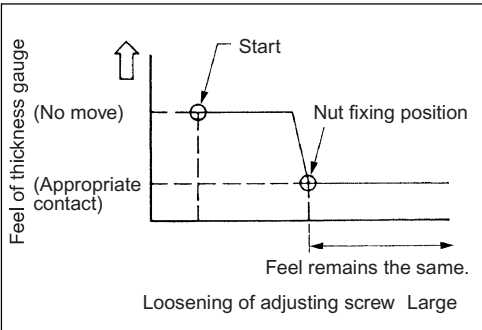

SAPH300020900179

- (6) Tighten the adjusting screw of the crosshead until the thickness gauge does not move.

- (7) While loosening the adjusting screw of the crosshead gradually, tighten the lock nut of the crosshead at the position where feel on the thickness gauge is appropriate.

Tightening torque : 25 N · m {250 kgf · cm, 18 lbf · ft}

- ⚠ CAUTION** • Do not over-loosen the adjusting screw. Over-loosening of the adjusting screw reproduces the original status. Although feel on the thickness gauge is appropriate, there is clearance between the adjusting screw and the valve of the crosshead. Correct adjustment is not allowed.

10 EXHAUST

Exhaust Manifold.....	10-2
Part layout.....	10-2
Replacement.....	10-3

Exhaust Manifold

Part layout

JP30002100402001

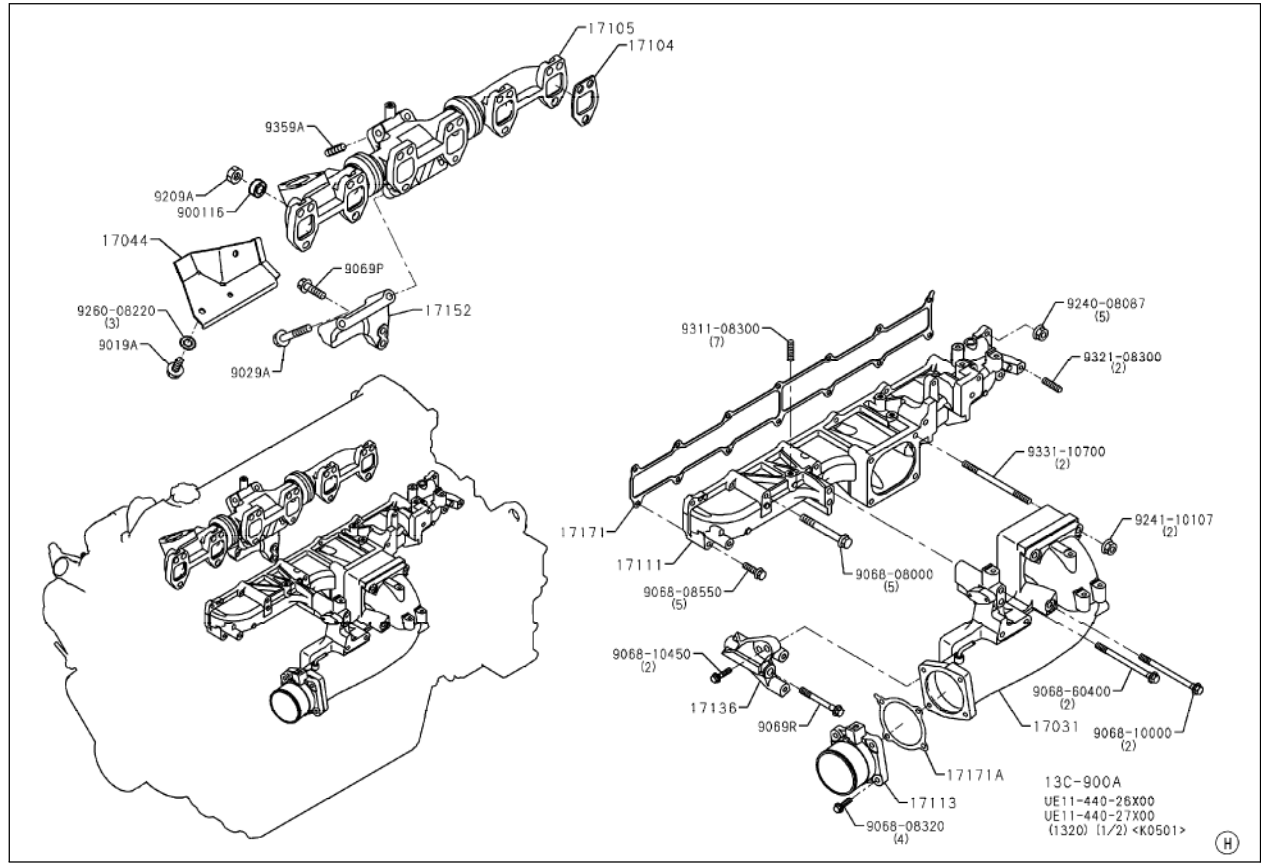

SAPH300021000001

17104	Gasket*	17105	Exhaust manifold
-------	---------	-------	------------------

*Parts not to be reused.

Tightening torque

9209A	53 N·m {540 kgf·cm, 40lb·ft}
-------	------------------------------

Replacement

JP30002100704001

1. Removal of exhaust manifold

- (1) Remove nuts and remove the exhaust manifold.

2. Replacement of stud bolt

- (1) Remove dirt (e.g. sealant) at the female thread of the cylinder head and clean the thread again with tap (M10 x 1.5).
- (2) Use the Torx wrench to tighten a new stud bolt.

Tightening torque : 30 N·m {300 kgf·cm, 22 lbf·ft}

⚠ CAUTION • Excessive tightening with over torque may cause crack in the cylinder head.

3. Installation of exhaust manifold

- (1) Assemble a new gasket.

⚠ CAUTION • Since a gasket has front and back, install the black side on the exhaust manifold.

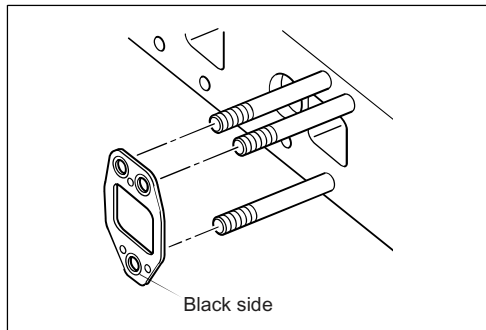

SAPH300021000002

- (2) Tighten the mounting nut of the exhaust manifold according to the order in the figure.

Tightening torque : 53 N·m {540 kgf·cm, 40 lbf·ft}

⚠ CAUTION • When nuts are tightened, prevent each spacer from riding on the counterbore area of the manifold flange.

• The tightening sequence of the exhaust manifold varies between use of a new part and reuse.

- (3) Tighten the same nuts again according to the order in the figure.

Tightening torque : 53 N·m {540 kgf·cm, 40 lbf·ft}

⚠ CAUTION • Be sure to retighten it.

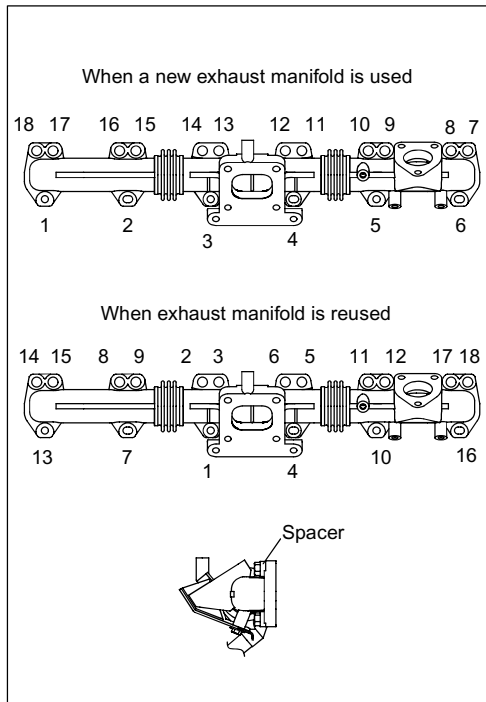

SAPH300021000003

11 COOLING

Cooling System	11-2
Cooling system drawing	11-2
Part layout	11-3
Replacement of thermostat case	11-4
Inspection of thermostat	11-5
Replacement of coolant pump	11-6

Cooling System

Cooling system drawing

JP30002110803001

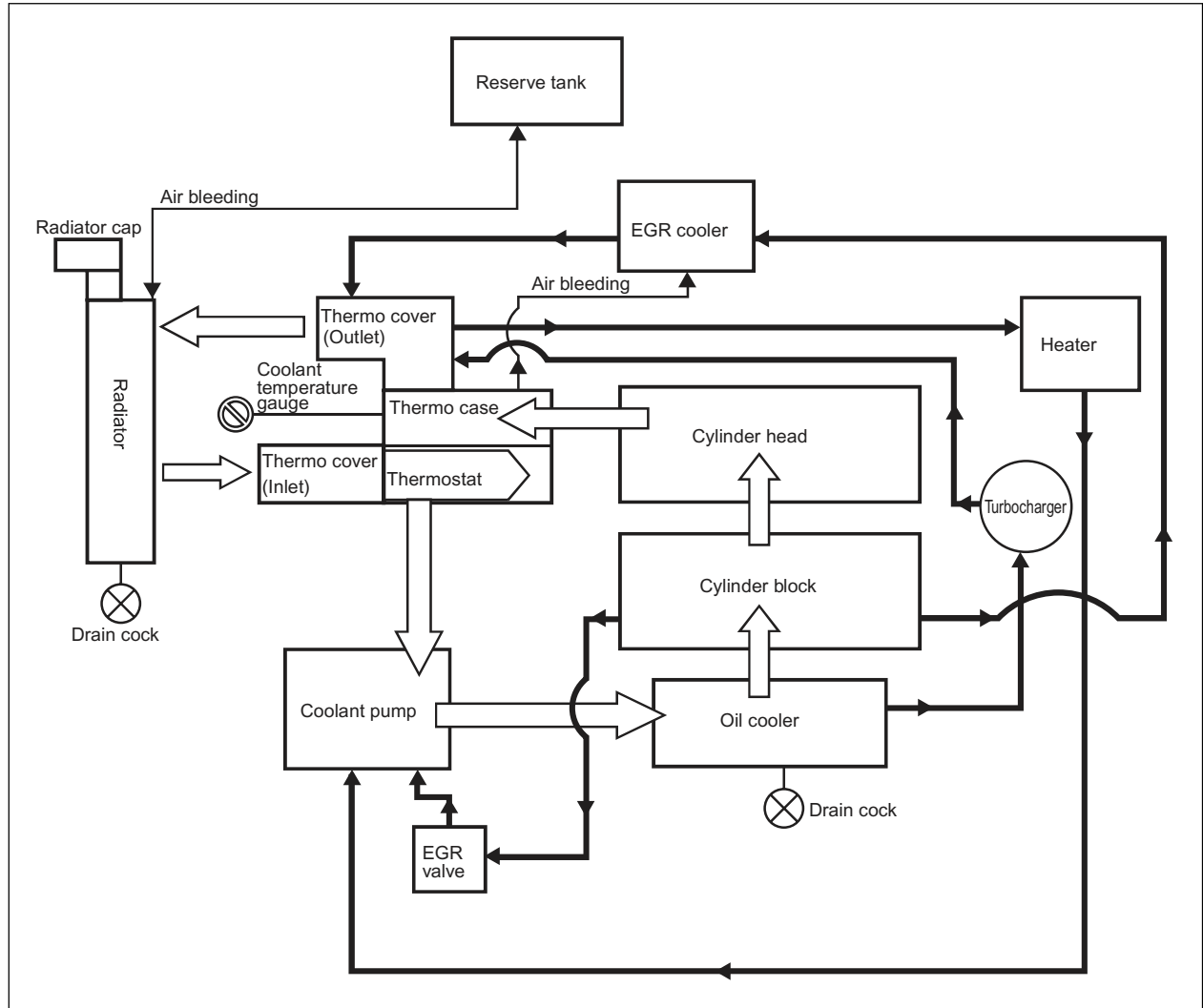

SAPH300021100001

Part layout

JP30002110402001

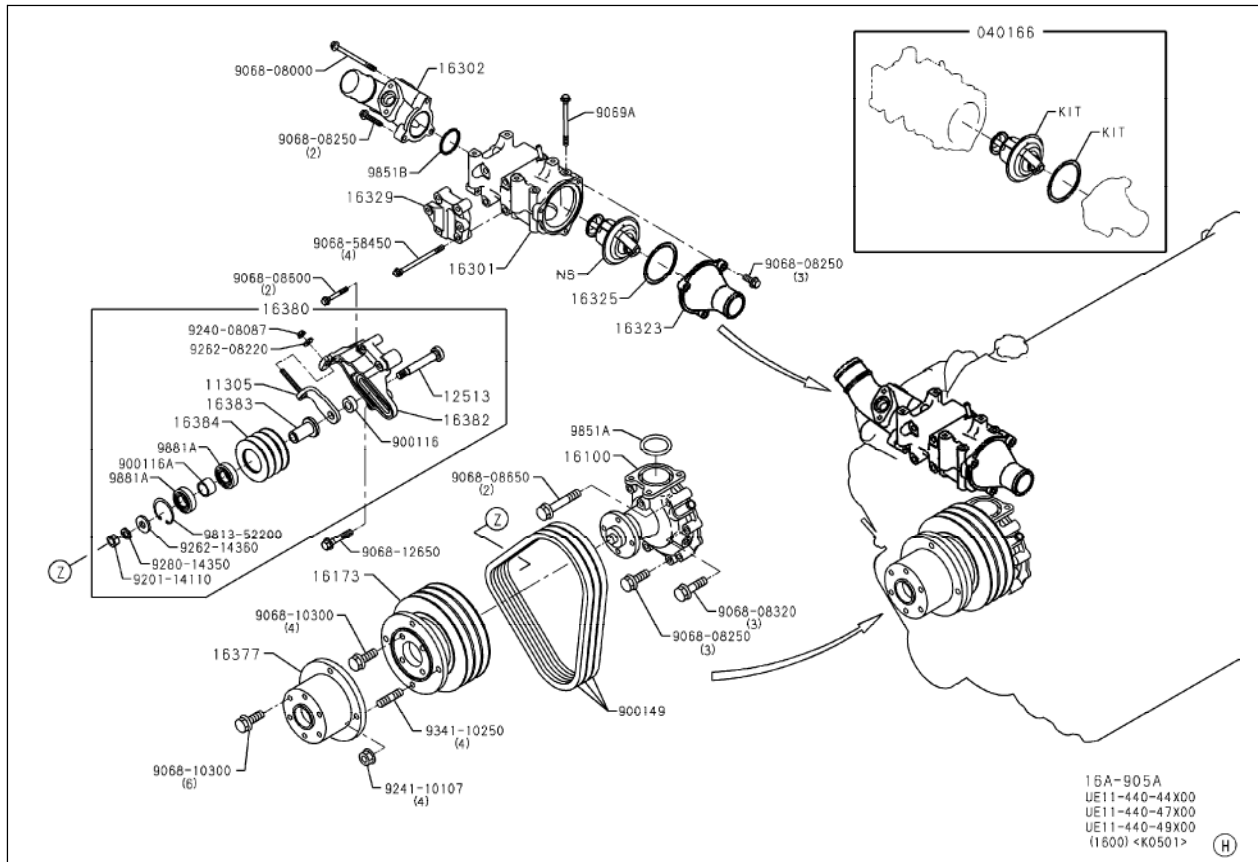

SAPH300021100002

16100	Coolant pump	16323	Thermostat case cover
16301	Thermostat case	16325	Gasket*
16302	Thermostat case cover	9851A	O-ring*

*Parts not to be reused.

Replacement of thermostat case

JP30002110704001

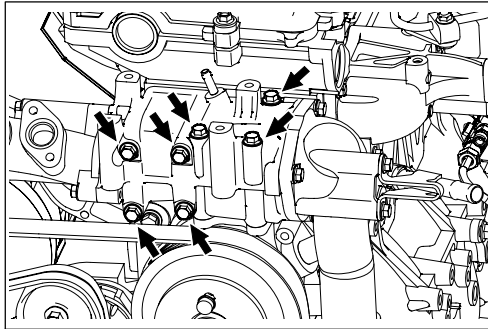

SAPH300021100003

1. Removal of thermostat case

- (1) Remove the EGR cooler.
Refer to "Inspection of EGR cooler, Emission control".
- (2) Remove bolts and remove the thermostat case.
- (3) Remove the O-ring from the groove on the coolant pump.

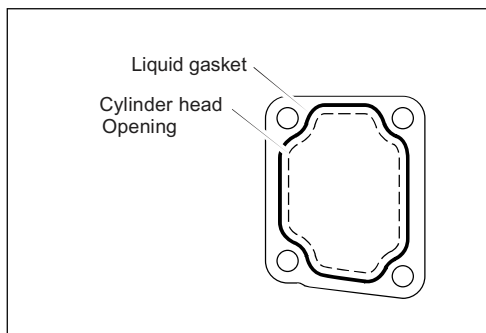

SAPH300021100004

2. Installation of thermostat case

- (1) Remove contamination on the joint between the thermostat case and the cylinder head using a scraper.
- (2) Apply liquid gasket [Threebond TB1207B(black) or equivalent] to the thermostat case as shown in the figure.

- ⚠ CAUTION**
- **Apply it continuously.**
 - **Apply the liquid gasket at the width of 1.5 to 2.5 mm{0.0591 to 0.0984 in.}.**
 - **Install the oil cooler within 20 minutes after application of the liquid gasket.**

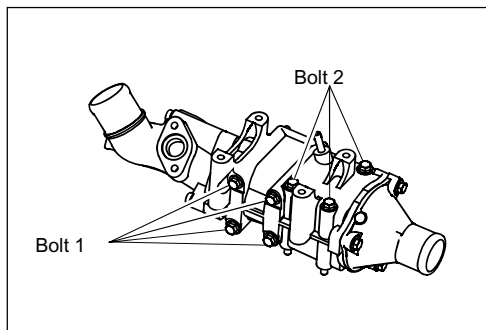

SAPH300021100005

- (3) Install the new O-ring on the groove of the coolant pump.
- (4) Put the thermostat case mounting bolt through the thermostat case in advance.
- (5) Align the thermostat case at the mounting position and tighten mounting bolt 1 temporarily to the cylinder head.
- (6) Tighten mounting bolt 2 temporarily to the coolant pump.
- (7) Tighten bolts in the order mounting bolt 1 to the cylinder head and mounting bolt 2 to the coolant pump.

Inspection of thermostat

JP30002110703001

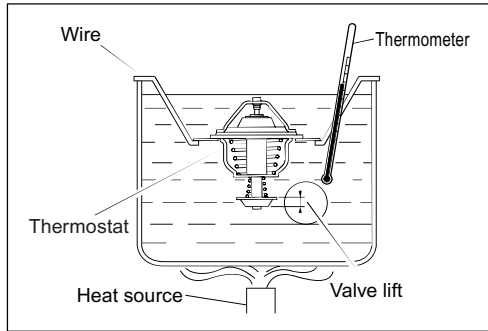

SAPH300021100006

1. Individual inspection of thermostat

- (1) Put the thermostat in water as shown in the figure and heat it.

CAUTION

- Support the thermostat in the center to prevent approach to the heat source.
- Stir the water well so that water temperature in the container may be uniform.

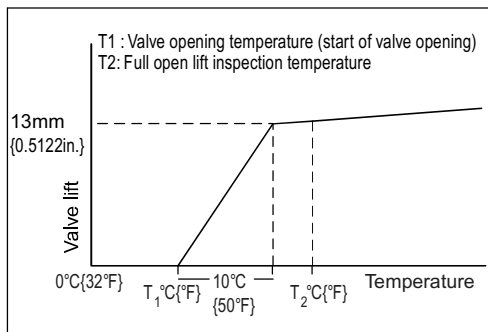

SAPH300021100007

- (2) Measure the temperature (valve opening temperature) that opens the thermostat valve.

Thermostat valve opening temperature standard value : T1(°C{°F})	74.5 - 76.5 {166.1 - 173.3}
---	------------------------------------

NOTICE

- The thermostat valve opening temperature (T1) is stamped on the thermostat seat.

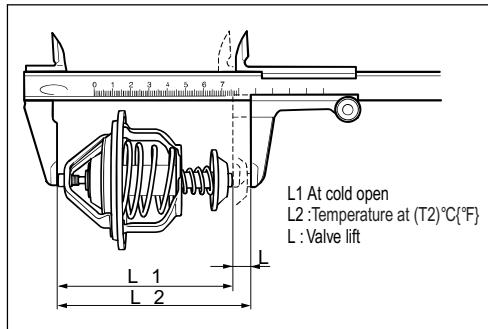

SAPH300021100008

- (3) Increase the water temperature to 95 °C{203° F} and measure the lift of the thermostat valve.

Thermostat valve full open lift inspection temperature : T2 (°C{°F})	Valve lift : L (mm{in.})
95{203}	13{0.5118} or more

- (4) Put the full open thermostat valve in water at normal temperature. Make sure that the thermostat valve closes completely within 5 minutes.
- (5) If faulty item is found with the inspection above, replace the thermostat.

Replacement of coolant pump

JP30002110704002

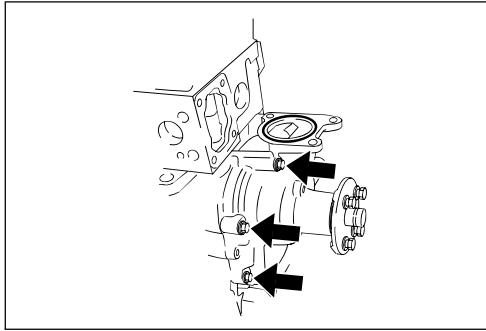

SAPH300021100009

1. Removal of coolant pump

- (1) Remove bolts and remove the coolant pump.

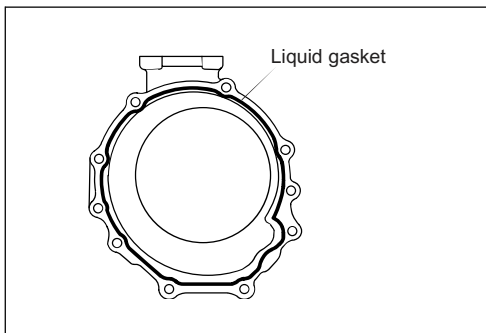

SAPH300021100010

2. Installation of coolant pump

- (1) Remove contamination on the joint surface between the coolant pump and the cylinder block using a scraper and degrease the surface.
- (2) Apply the liquid gasket [Threebond TB1207B (black) or equivalent] to the coolant pump as shown in the figure.



CAUTION

- Apply it continuously.
- Apply the liquid gasket at the width of 2 to 3mm{0.0787 to 0.1181in.}.
- Install the oil cooler within 20 minutes after application of the liquid gasket.
- Fill the groove on the water pump flange with the liquid gasket.

- (3) Install the coolant pump to the dowel pin of the cylinder block.

NOTICE

- When the coolant pump is installed using a guide bolt, displacement of the liquid gasket does not occur.

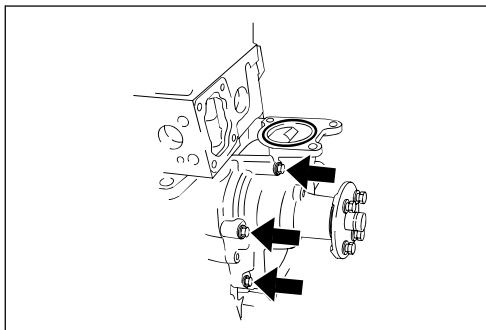

SAPH300021100009

12 LUBRICATION

Oil Cooler, Oil Filter and Oil Pump	12-2
System drawing	12-2
Part layout.....	12-3
Part layout.....	12-4
Replacement of oil cooler	12-5
Overhaul of oil cooler	12-6
Replacement of oil pump	12-8
Overhaul of oil pump.....	12-9
Replacement of oil strainer	12-12
Oil Pan	12-13
Part layout.....	12-13
Replacement.....	12-14
Inspection of lubrication status	12-15

Oil Cooler, Oil Filter and Oil Pump

System drawing

JP30002120805001

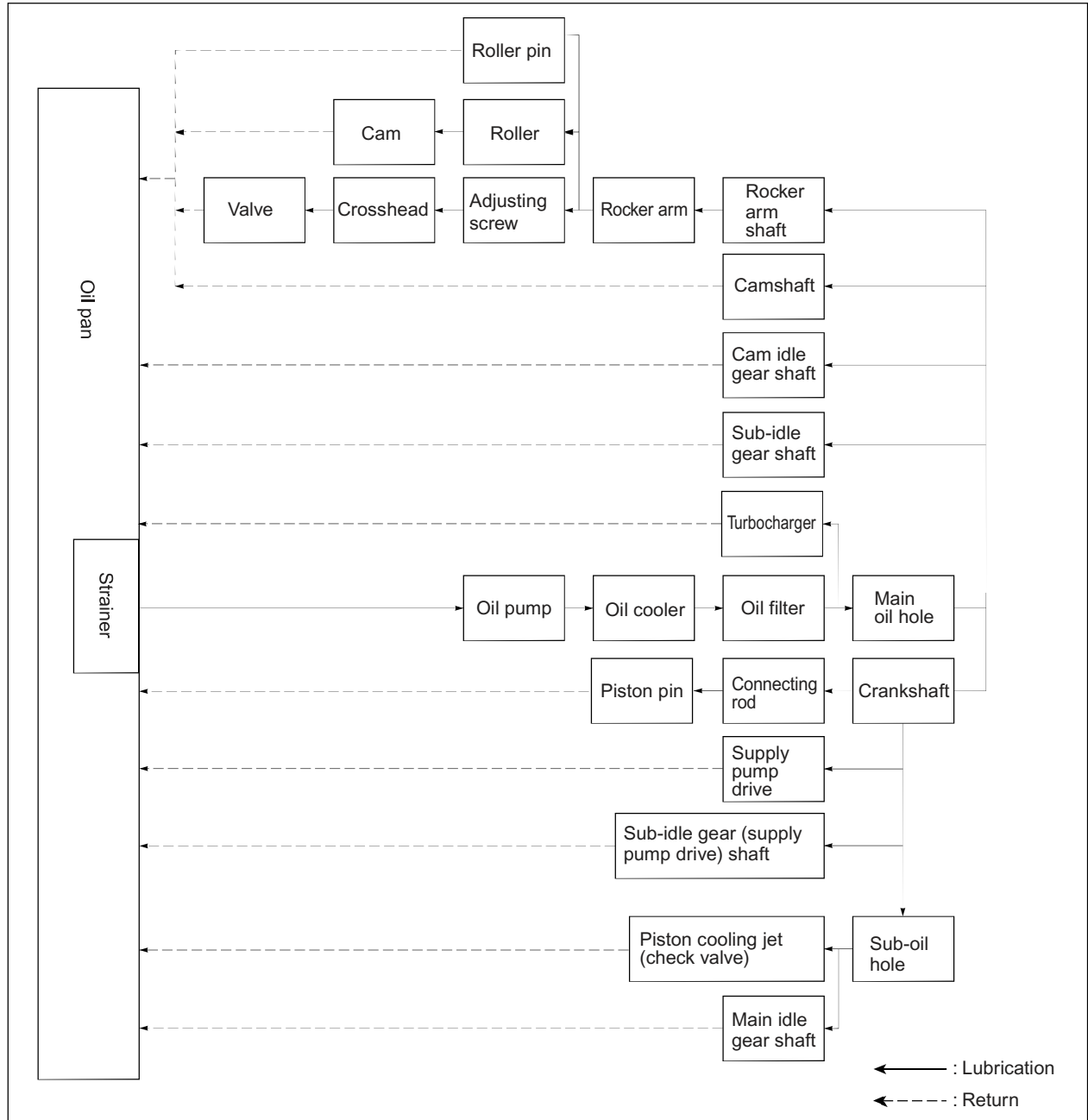

SAPH300021200001

Part layout

JP30002120402001

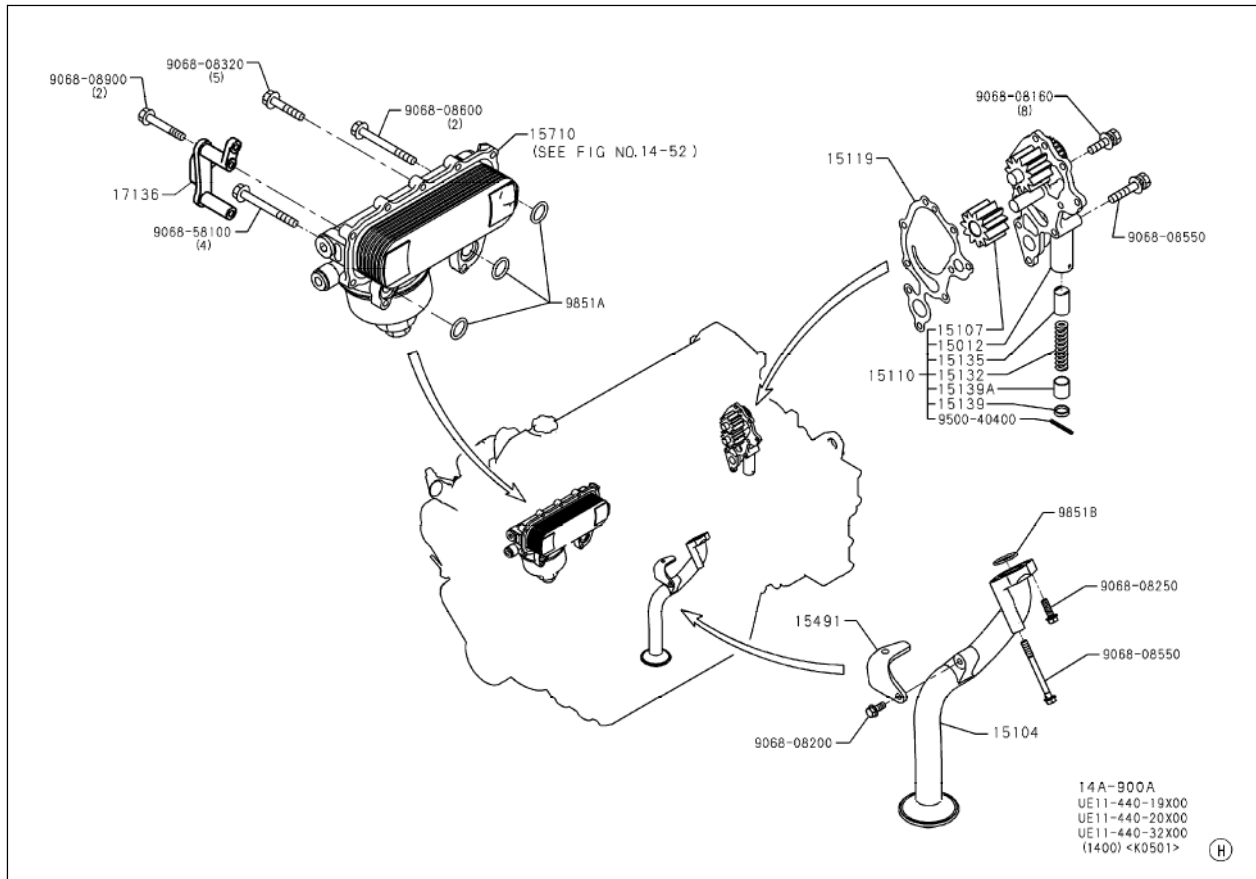

SAPH300021200002

15012	Oil pump cover assembly	15135	Relief valve
15104	Oil strainer	15710	Oil cooler
15107	Driven gear	9500-40400	Cotter pin*
15119	Gasket*	9851A	O-ring*
15132	Spring		

*Parts not to be reused.

Tightening torque

9068-08160	28.5N·m {290kgf·cm, 21lbf·ft}	9068-08550	31N·m {320kgf·cm, 23lbf·ft} (Oil strainer area)
9068-08250	31N·m {320kgf·cm, 23lbf·ft}	9068-08600	24.5±4.9N·m {250±50kgf·cm, 18±4lbf·ft}
9068-08320	24.5±4.9N·m {250±50kgf·cm, 18±4lbf·ft}	9068-08900	24.5±4.9N·m {250±50kgf·cm, 18±4lbf·ft}
9068-08550	28.5N·m {290kgf·cm, 21lbf·ft} (Oil pump area)	9068-58100	24.5±4.9N·m {250±50kgf·cm, 18±4lbf·ft}

Part layout

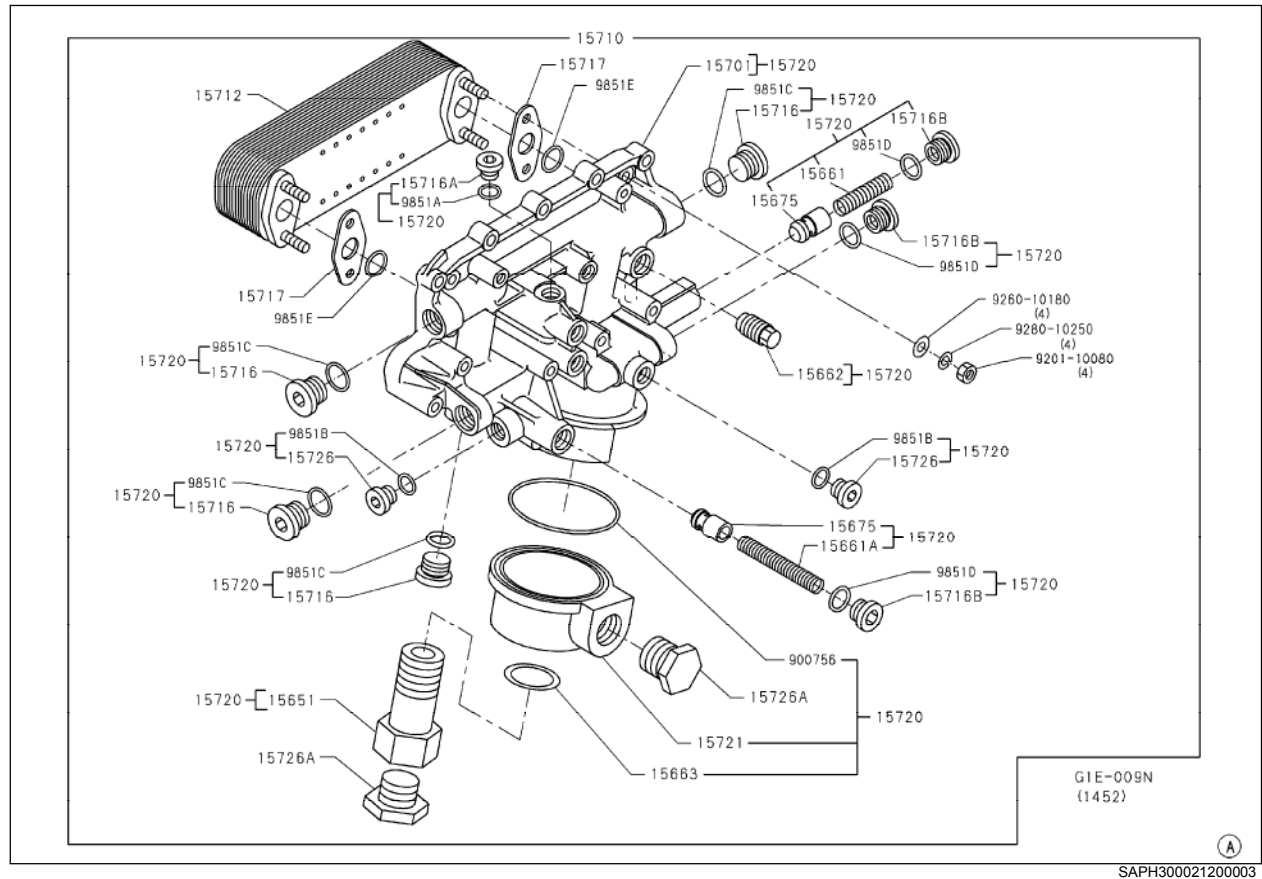

SAPH300021200003

15662	Drain plug	15720	Oil cooler case assembly
15675	Safety valve	9851A	O-ring*
15701	Oil cooler case	9851B	O-ring*
15710	Oil cooler	9851C	O-ring*
15712	Oil cooler	9851D	O-ring*
15717	Gasket*	9851E	O-ring*

*Parts not to be reused.

Tightening torque

15662	44.1±4.9 N·m {450±50 kgf·cm, 33±4llbf·ft}	
-------	--	--

Replacement of oil cooler

JP30002120704001

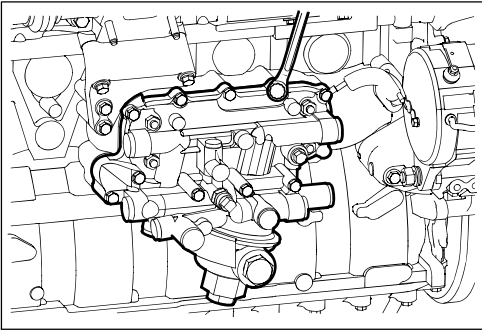

SAPH300021200004

1. Removal of oil cooler

- (1) Remove bolts and remove the oil cooler.

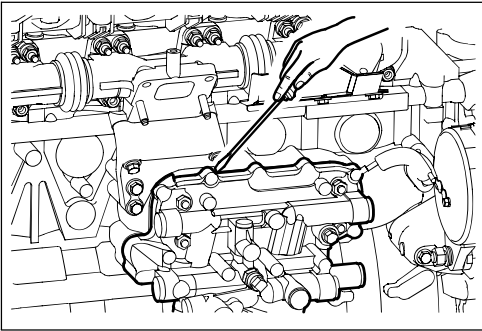

SAPH300021200005

- (2) If it is difficult to remove the oil cooler due to liquid gasket sticking to the cylinder block, put a flat tip screwdriver at the protrusion in the figure for removal.

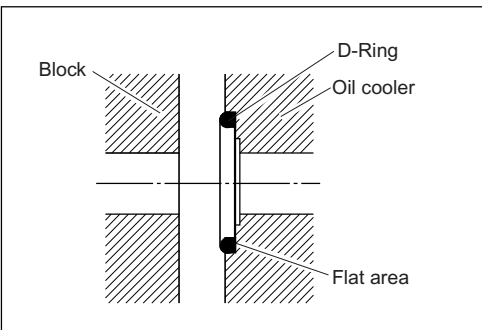

SAPH300021200006

2. Installation of oil cooler

- (1) Assemble the new D-ring into the D-ring groove of the oil cooler.

⚠ CAUTION • Face the D-ring flat area toward the oil cooler.

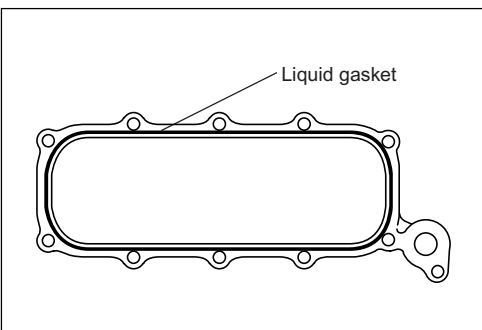

SAPH300021200007

- (2) Remove contamination on the joint surface between the oil cooler and the cylinder block using a scraper. Apply the liquid gasket [Threebond TB1207 (silver) or equivalent] to the oil cooler as shown in the figure.

⚠ CAUTION • Apply it continuously.
 • Apply the liquid gasket at the width of 1.5 to 2.5 mm{0.0590 to 0.0984 in.}.
 • Install the oil cooler within 20 minutes after application of the liquid gasket.

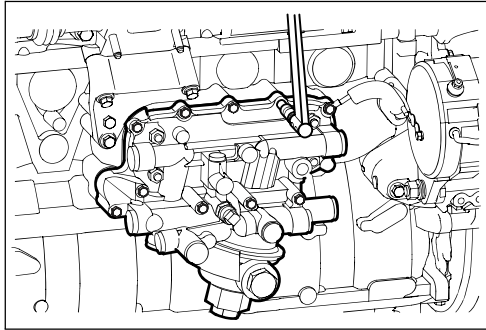

SAPH300021200008

- (3) Insert the positioning stud into the screw hole of the cylinder block and install the oil cooler.
- (4) After temporary tightening with bolts, remove the positioning stud and tighten bolts.

Tightening torque :

24.5±4.9 N·m {250±50 kgf·cm, 18±4 lbf·ft}

- ⚠ CAUTION**
- Tighten together with the alternator ground.
 - Be sure to connect the turbocharger lubricating oil hose.

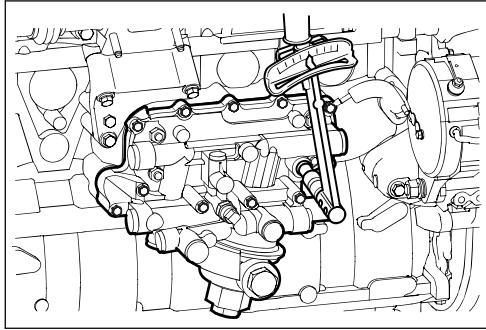

SAPH300021200009

- (5) Install the drain plug.

Tightening torque :

44.1±4.9 N·m {450±50 kgf·cm, 33±4 lbf·ft}

- ⚠ CAUTION**
- If a new part is used, tighten it to **58.8±4.9N·m {600±50kgf·cm, 43±4lbf·ft}** and loosen it. Then, tighten it again to the torque above.

Overhaul of oil cooler

JP30002120702001

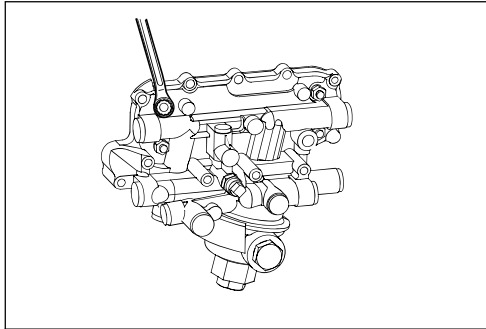

SAPH300021200010

1. Removal of oil cooler element

- (1) Remove nuts and remove the oil cooler element.

2. Inspection of oil cooler element

- (1) Wash water and oil channels with kerosene oil or washing fluid.
- (2) Check for crack or deformation on the stud bolt mounting area and element visually.
- (3) Blow air of approx. 0.5kgf/cm² into the oil channel to check for leak from parts. If crack, leak or deformation is found, replace it with a new part.

3. Disassembly of oil cooler case

- ⚠ CAUTION**
- Disassembly immediately after stop of the engine may cause blowout of engine oil.

- (1) Remove valve spring plugs and safety valves using a hexagonal wrench.
- (2) Remove the hydraulic pressure warning switch.

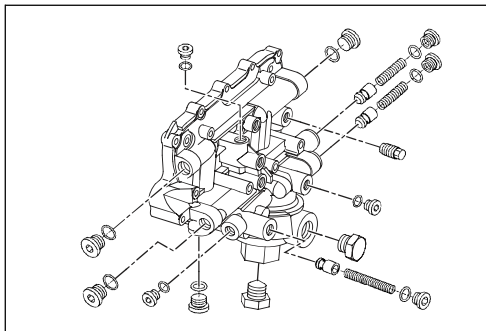

SAPH300021200011

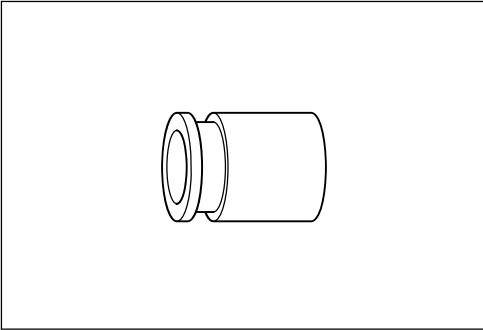

SAPH300021200012

4. Inspection of safety valve wear and damage

- (1) If wear or damage is found, replace it.

5. Inspection of oil pressure warning switch

- (1) For inspection of oil pressure warning switch, refer to "Inspection of components"- "Electrical".

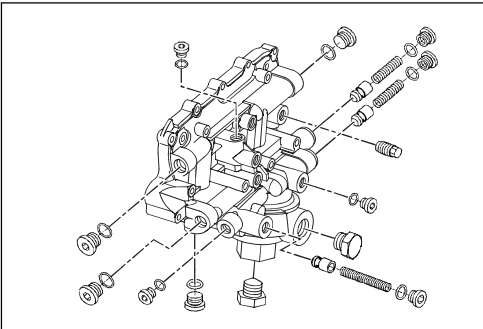

SAPH300021200011

6. Assembly of oil cooler case

- (1) Install a new O-ring and install valve spring plugs and safety valves using a hexagonal wrench.

Tightening torque :

$24.5 \pm 4.9 \text{ N} \cdot \text{m}$ { $250 \pm 50 \text{ kgf} \cdot \text{cm}$, $18 \pm 4 \text{ lbf} \cdot \text{ft}$ } (M14, M20)

$29.4 \pm 4.9 \text{ N} \cdot \text{m}$ { $300 \pm 50 \text{ kgf} \cdot \text{cm}$, $22 \pm 4 \text{ lbf} \cdot \text{ft}$ } (M22)

$34.3 \pm 4.9 \text{ N} \cdot \text{m}$ { $350 \pm 50 \text{ kgf} \cdot \text{cm}$, $25 \pm 4 \text{ lbf} \cdot \text{ft}$ } (M24)

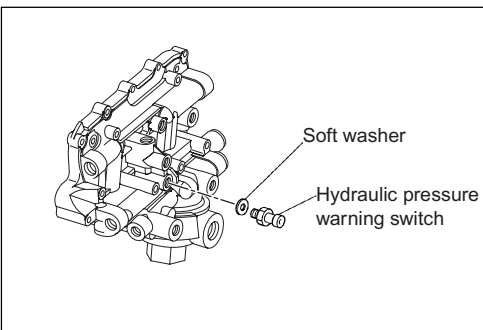

SAPH300021200031

- (2) Apply the liquid gasket [Threebond TB1211 (white) or equivalent] to the sealing surface of a new soft washer.
- (3) Install the soft washer in (2) and the hydraulic pressure warning switch.

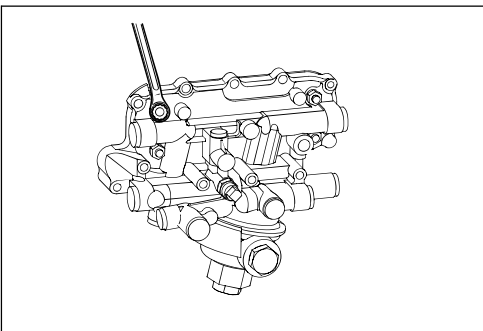

SAPH300021200010

7. Installation of oil cooler element

- (1) Assemble new gasket and new O-ring and assemble the oil cooler element with nuts.

Tightening torque :

$24.5 \pm 4.9 \text{ N} \cdot \text{m}$ { $250 \pm 50 \text{ kgf} \cdot \text{cm}$, $18 \pm 4 \text{ lbf} \cdot \text{ft}$ }

- ⚠ CAUTION** • In handling the oil cooler element, be careful not to give damage to it.

Replacement of oil pump

JP30002120704002

1. Removal of oil pump

- (1) Dismount the engine from the vehicle.
- (2) Remove the flywheel.
- (3) Remove the flywheel housing.
- (4) Remove the timing gear.
- (5) Remove the oil pump.

2. Installation of oil pump

- (1) Apply engine oil to the pump case and the bearing (shaded area) of the cylinder block.

⚠ CAUTION • Without application of engine oil, poor oil suction may occur at the initial start, resulting in seizure or abnormal wear.

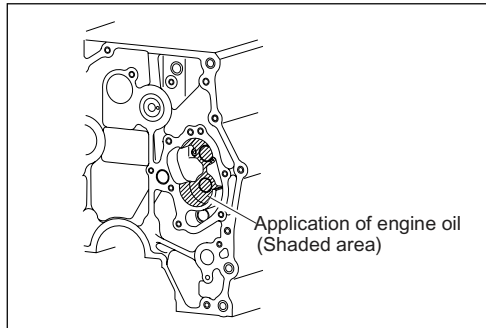

SAPH300021200013

- (2) To prevent bolt hole offset of the gasket, apply engine oil to the cylinder block in advance and place and fix the gasket.

⚠ CAUTION • Assembly with offset gasket may cause faulty sealing. Oil in the oil pump may be completely discharged when the engine stops. Faulty sealing may cause insufficient suction of oil at initial revolution of engine restart, resulting in seizure or abnormal wear.

- (3) Tighten the oil pump according to the order in the figure.
Tightening torque : 28.5 N · m {290 kgf · cm, 21 lbf · ft}

⚠ CAUTION • If the tightening order is not observed, the oil pump may be damaged.

- After tightening, make sure that the gear can be turned with hand.

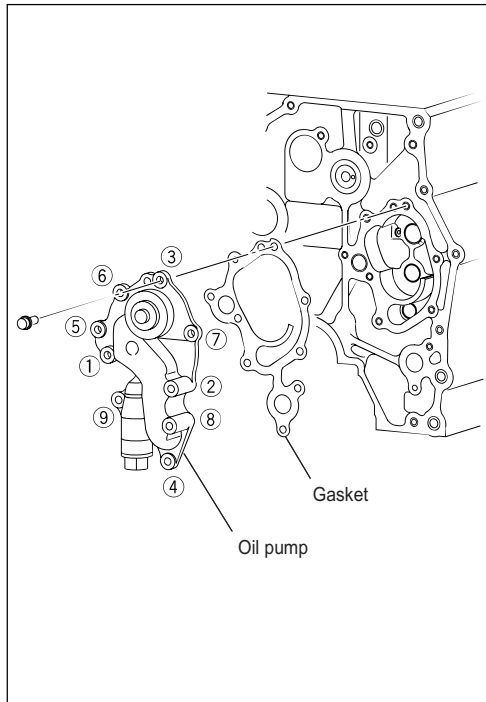

SAPH300021200014

Overhaul of oil pump

JP30002120702002

1. Remove the driven gear.

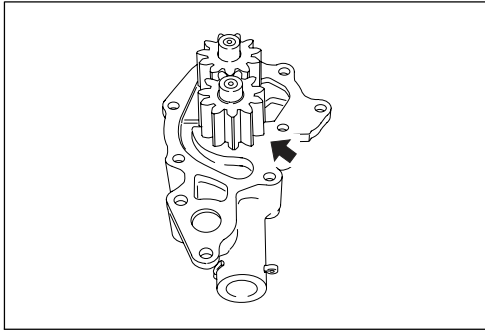

SAPH300021200015

2. Remove the cotter pin and remove seat 2, seat 1, relief valve spring and safety valve.

⚠ CAUTION • When the cotter pin is removed, seat 2 and the relief valve spring may eject out.

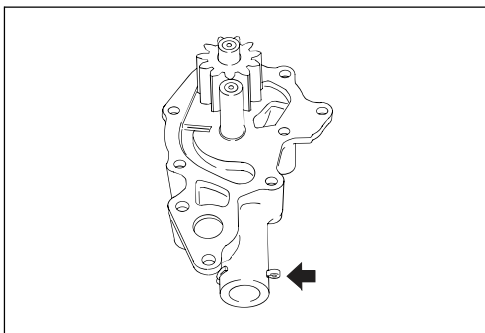

SAPH300021200016

3. Inspection of clearance between drive gear and cylinder block

- (1) Measure the outer diameter of the drive gear and the inner diameter of the pump chamber at cylinder block.

Measuring area	Standard value (mm{in.})
Outer diameter of drive gear	54{2.1260}
Inner diameter of pump chamber at cylinder block	54{2.1260}

- (2) Calculate the difference between the outer diameter of the drive gear and the inner diameter of the pump chamber at the cylinder block. If it is beyond the service limit, replace the oil pump assembly.

Standard value (mm{in.})	Service limit (mm{in.})
0.100 - 0.202{0.0039 - 0.0080} (reference)	0.30{0.0118}

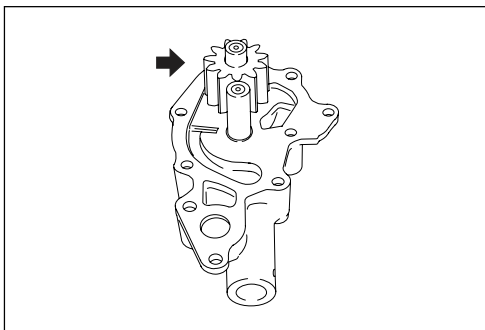

SAPH300021200017

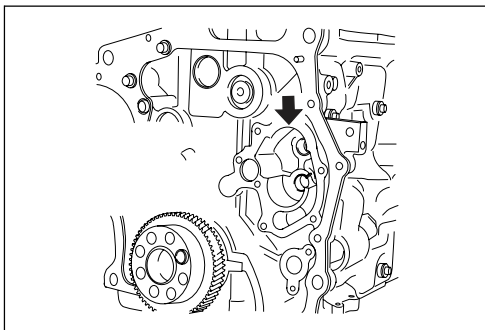

SAPH300021200018

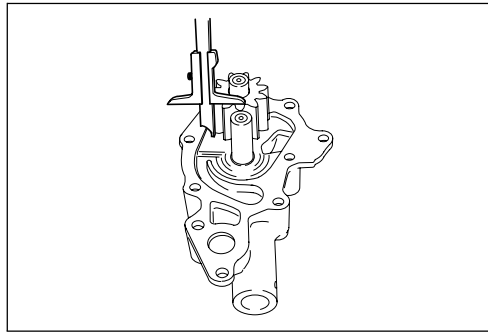

SAPH300021200019

4. End play inspection between drive gear and cylinder block

- (1) Measure the drive gear width and the pump chamber depth at the cylinder block using a depth gauge.

Measuring area	Standard value (mm{in.})
Width of drive gear	37.5{1.4764}
Depth of pump chamber at cylinder block	37.5{1.4764}

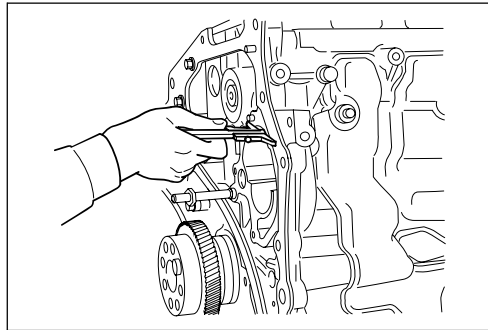

SAPH300021200020

- (2) Calculate the difference between the depth of the drive gear and the pump chamber depth at the cylinder block. If it is beyond the service limit, replace the oil pump assembly.

Standard value (mm{in.})	Service limit (mm{in.})
0.049 - 0.113{0.0020 - 0.0044} (reference)	0.15{0.0060}

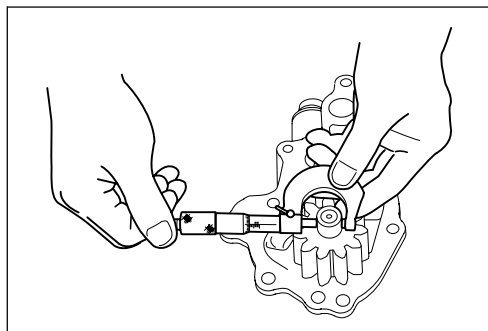

SAPH300021200021

5. Inspection of clearance between outer diameter of driven gear shaft and cylinder block hole diameter

- (1) Measure the outer diameter of the driven gear shaft using a micrometer and measure the cylinder block hole diameter using a cylinder gauge.

Measuring area	Standard value (mm{in.})
Outer diameter of driven gear shaft	18{0.7087}
Cylinder block hole diameter	18{0.7087}

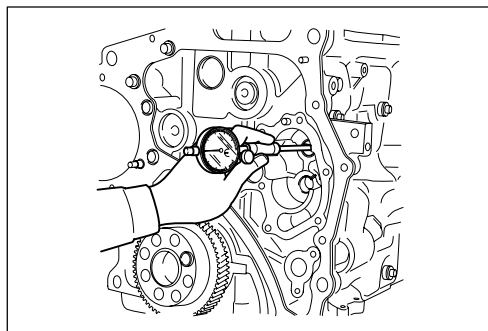

SAPH300021200022

- (2) Calculate the difference between the outer diameter of the driven gear and the cylinder block hole diameter. If it is beyond the service limit, replace the oil pump assembly.

Standard value (mm{in.})	0.040 - 0.099 {0.0016 - 0.0039}
--------------------------	---------------------------------

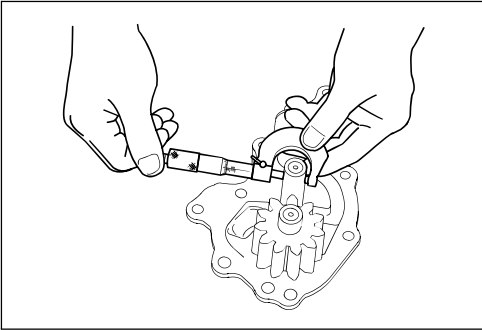

SAPH300021200023

6. Inspection of clearance between outer diameter of driven gear shaft and inner diameter of driven gear bushing

- (1) Measure the outer diameter of the driven gear shaft using a micrometer and measure the inner diameter of the driven gear bushing using a cylinder gauge.

Measuring area	Standard value (mm{in.})
Outer diameter of driven gear shaft	18{0.7087}
Cylinder block hole diameter	18{0.7087}

- (2) Calculate the difference between the outer diameter of the driven gear and the cylinder block hole diameter. If it is beyond the service limit, replace the oil pump assembly.

Standard value (mm{in.})	0.030 - 0.075 {0.0012 - 0.0030}
--------------------------	------------------------------------

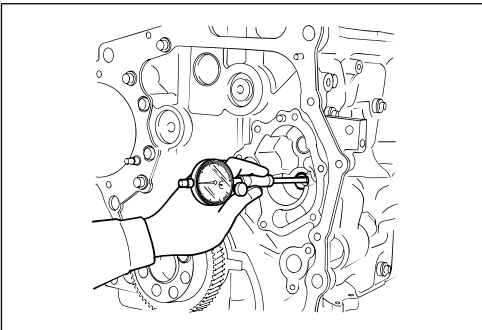

SAPH300021200024

7. Inspection of clearance between outer diameter of driven gear shaft and inner diameter of driven gear bushing

- (1) Measure the outer diameter of the driven gear shaft using a micrometer and measure the inner diameter of the driven gear bushing using a cylinder gauge.

Measuring area	Standard value (mm{in.})
Outer diameter of driven gear shaft	18{0.7087}
Inner diameter of driven gear bushing	18{0.7087}

- (2) Calculate the difference between the outer diameter of the driven gear shaft and the inner diameter of the driven gear bushing. If it is beyond the service limit, replace the oil pump assembly or the driven gear bushing.

Standard value (mm{in.})	Service limit (mm{in.})
0.040 - 0.083 {0.0016 - 0.0033}	0.15{0.00059}

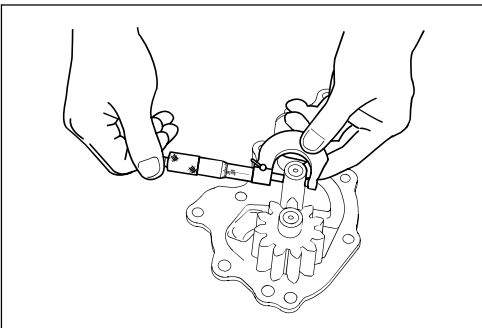

SAPH300021200023

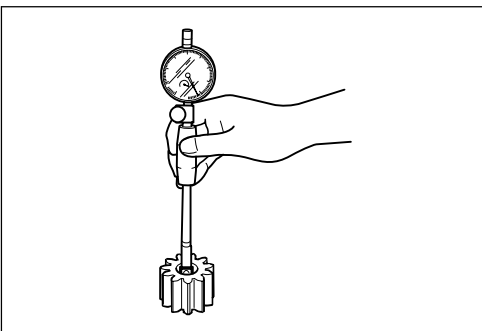

SAPH300021200025

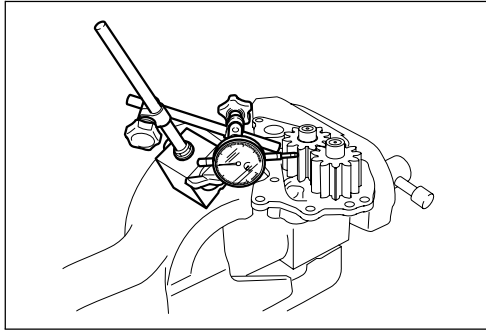

SAPH300021200026

8. Inspection of drive gear backlash

- (1) Fix the oil pump assembly with a vice.
- (2) Measure backlash between the drive gear and the driven gear using a dial gauge. If it is beyond the service limit, replace the oil pump assembly.

Standard value (mm{in.})	Service limit (mm{in.})
0.073 - 0.207 {0.0029 - 0.0081}	0.30{0.0118}

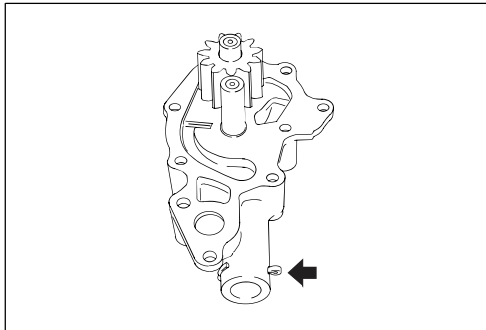

SAPH300021200016

9. Assembly of oil pump

- (1) Install the safety valve, relief valve, seat 1 and seat 2 on the oil pump cover assembly with new cotter pins.

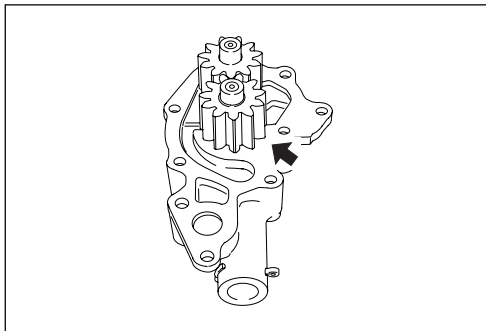

SAPH300021200015

- (2) Install the driven gear.

Replacement of oil strainer

JP30002120704003

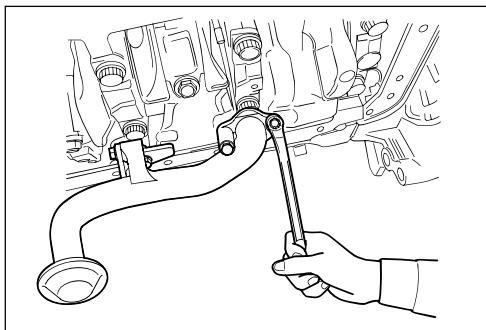

SAPH300021200027

1. Removal of oil strainer

- (1) Remove bolts and remove the oil strainer.

2. Installation of oil strainer

- (1) Install the oil strainer.

Tightening torque : 31 N · m {320 kgf · cm, 23 lbf · ft}

Oil Pan

Part layout

JP30002120402003

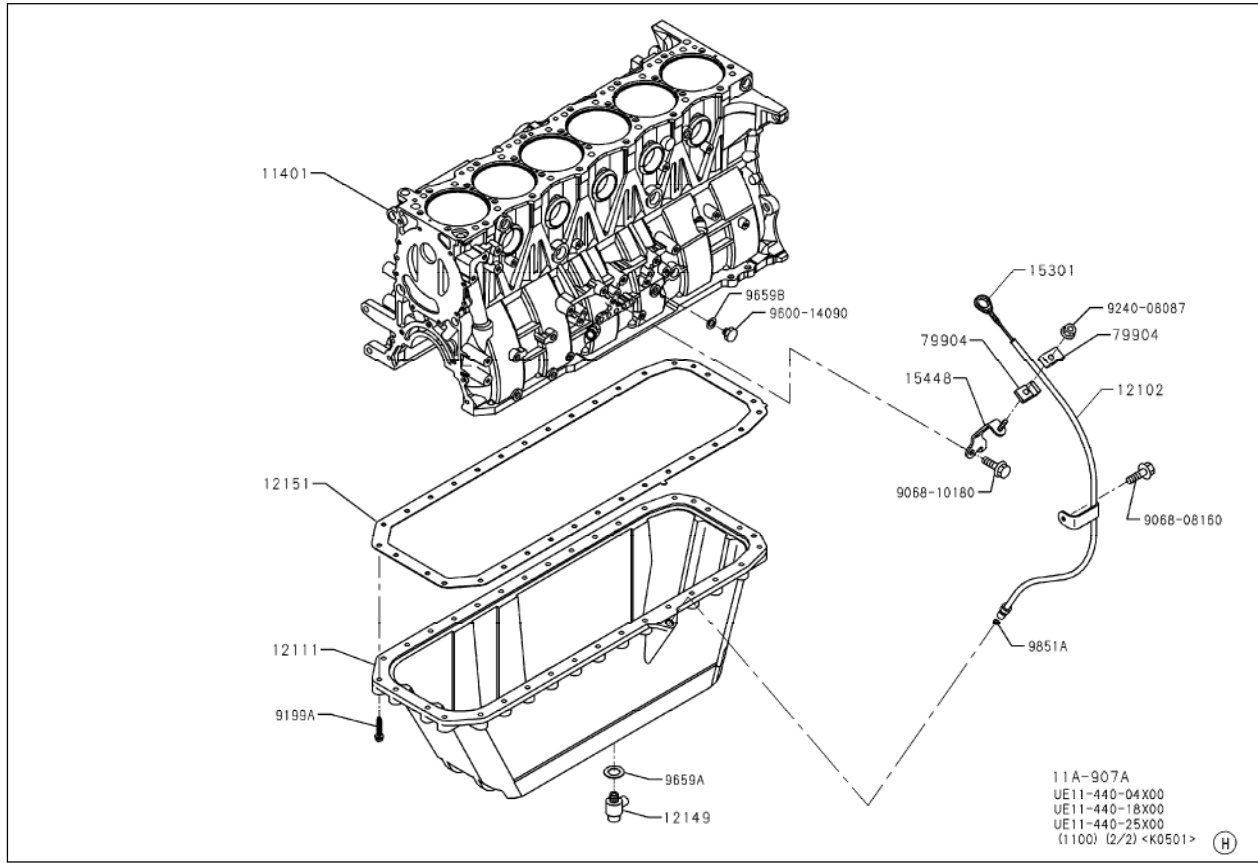

SAPH300021200028

12101	Oil pan assembly	12149	Drain plug
12151	Oil pan gasket*	9659A	Gasket*

*Parts not to be reused.

Tightening torque

9199A	30 N·m {300 kgf·cm, 22 lbf·ft}	12149	41 N·m {420 kgf·cm, 30 lbf·ft}
-------	--------------------------------	-------	--------------------------------

Replacement

JP30002120704004

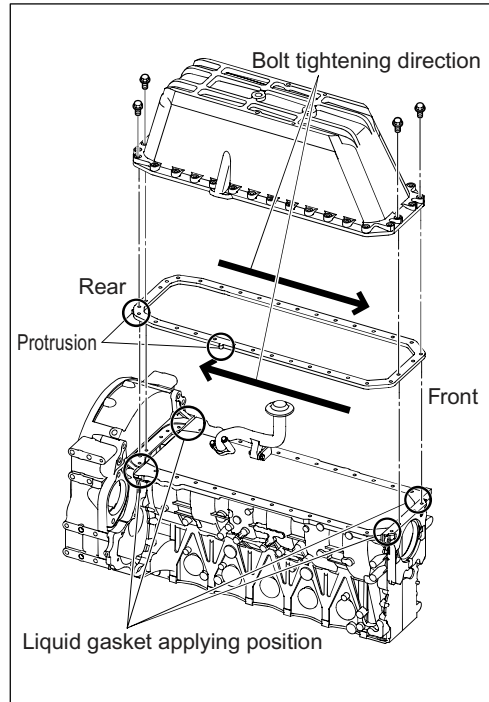

1. Installation of oil pan

- (1) Cut the gasket of the rear end plate to be flush to the cylinder block lower surface using a scraper.
- (2) Make sure that there is no deformation, dirt or oil on the joint surface between the cylinder block and the oil pan. Apply liquid gasket [Threebond TB1207D (silver) or equivalent] to the front rear end of the cylinder block lower surface.
- (3) Insert several stud bolts (70 mm{2.7559 in.} or larger) for positioning into the cylinder block screw hole.
- (4) Position the gasket protrusion at the intake side and the flywheel housing (printed seal surface at cylinder block). Align the new gasket and oil pan to the cylinder block lower surface and tighten bolts in the arrow order of the figure.

Tightening torque :

19.6 - 24.5 N·m {200 - 250 kgf·cm, 14 - 18 lbf·ft}

- (5) Remove positioning stud bolts and install the correct bolts.
- (6) Tighten bolts in the arrow order of the figure.

Tightening torque : 30 N·m {300 kgf·cm, 22 lbf·ft}

- ⚠ CAUTION**
- Check if the washer is not riding on the flange.
 - Make sure that the printed seal is not peeled or damaged before installation of the gasket.

Inspection of lubrication status

JP30002120703001

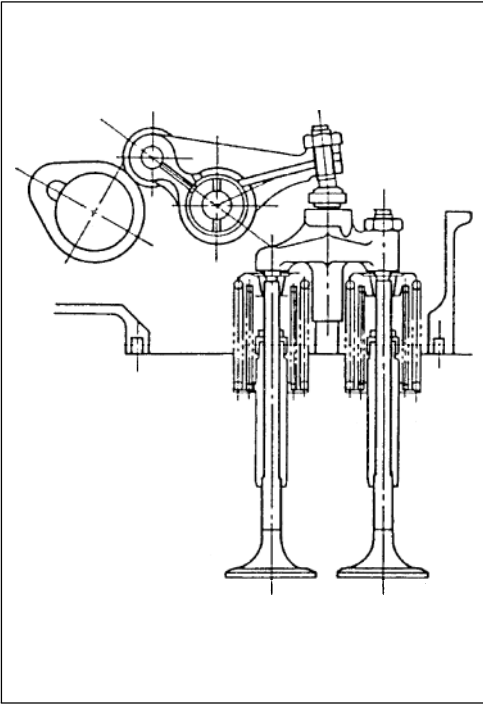

SAPH300021200030

1. Inspection of valve system

⚠ CAUTION • Perform inspection with the water temperature at 60 °C{140° F}.

(1) Remove the head cover.

⚠ CAUTION • To prevent spread of engine oil, attach a jig which cuts a head cover in half. Cut it to the degree that the camshaft is covered.

(2) Adjust the engine revolution to the standard idling revolution [550r/min{rpm}].

(3) After start of the engine, make sure that oil is supplied to the areas below of all rocker arms within about 10 seconds.

- Roller and cam surface
- Cross head and spring upper seat surface through adjusting screw

⚠ CAUTION • If time until lubrication is long or if lubrication is not performed, the oil pressure may be low or the oil channel may be clogged. Seizure, abnormal wear or abnormal noise may occur due to insufficient lubrication.

13 STARTING AND CHARGING

Starter	13-2
Part layout (typical example)	13-2
Disassembly	13-3
Inspection of components	13-9
Assembly	13-14
Alternator (60A)	13-21
Part layout (typical example of 60A)	13-21
Circuit drawing (60A)	13-22
Disassembly (60A)	13-23
Inspection of components (60A)	13-26
Assembly (60A)	13-29
Inspection after assembly (60A)	13-33

Starter

Part layout (typical example)

JP30002130402001

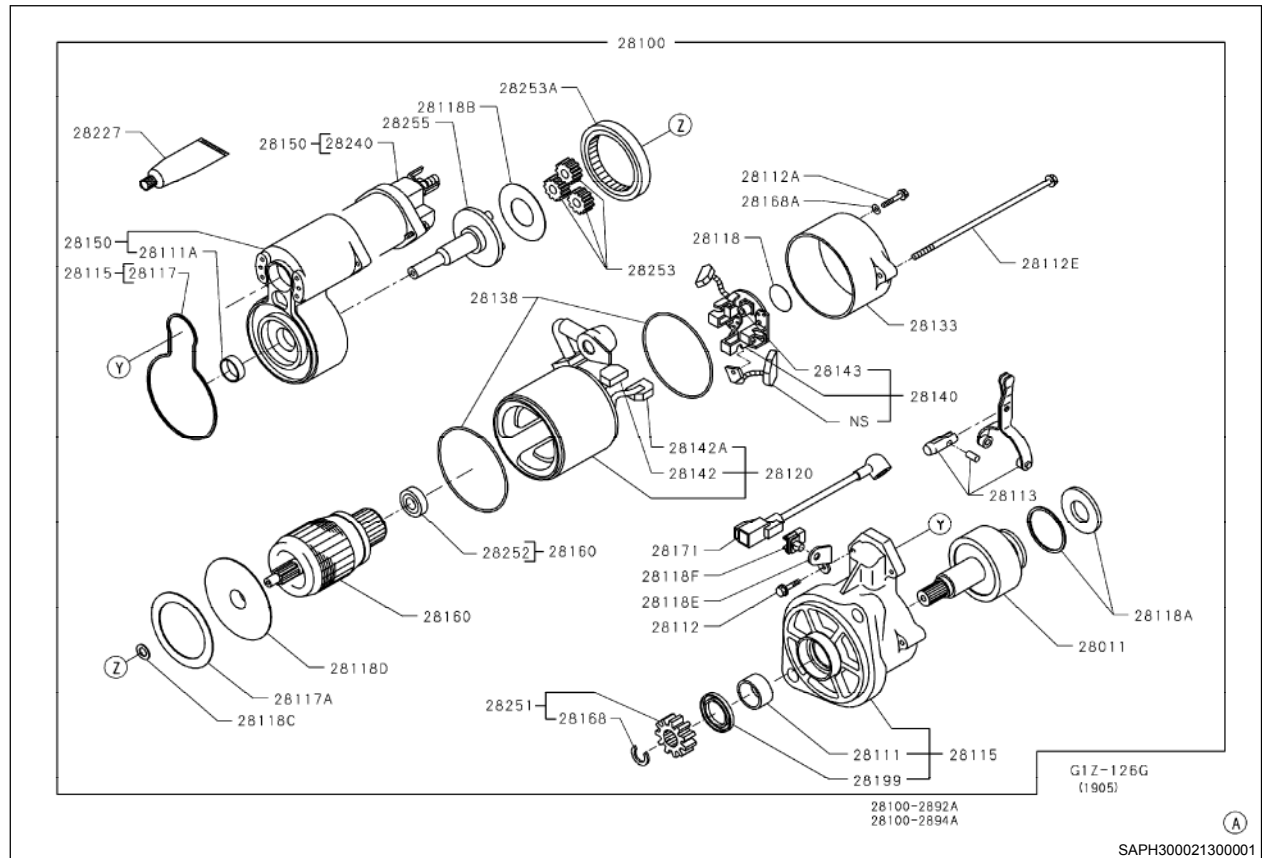

28011	Clutch subassembly	28138	Packing*
28100	Starter	28140	Brush holder assembly
28111	Bushing	28142	Brush
28111A	Bushing	28143	Spring
28113	Lever	28150	Center bracket
28115	Start drive housing	28160	Armature assembly
28117	Packing*	28168	Pinion stopper
28117A	Packing*	28199	Dust protector
28118	Plate	28240	Start magnet switch
28118A	Plate	28251	Pinion
28118B	Plate	28252	Bearing
28118C	Plate	28255	Shaft assembly
28118D	Cover	28253	Planetary gear
28120	Yoke assembly	28253A	Internal gear
28133	Commutator end frame		

*Parts not to be reused.

Tightening torque

28112	14-16 N·m {140-160kgf·cm, 10-12lbf·ft}	28112E	15.7-17.6 N·m {160-179kgf·cm, 12-13lbf·ft}
28112A	3.6-4.9 N·m {37-49kgf·cm, 3-4lbf·ft}		

Disassembly

JP30002130702001

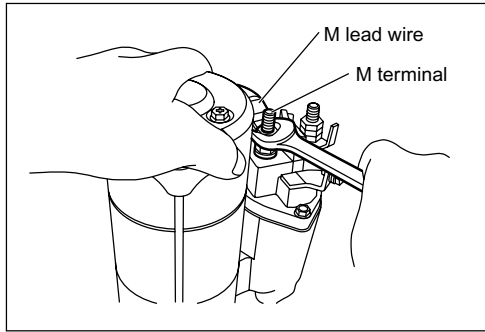

SAPH300021300002

NOTICE • Fix the starter on the working table to ease accessibility.

1. MRemoval of lead wire

- (1) Remove the cap of the M terminal.
- (2) Remove nuts and remove the M lead wire.

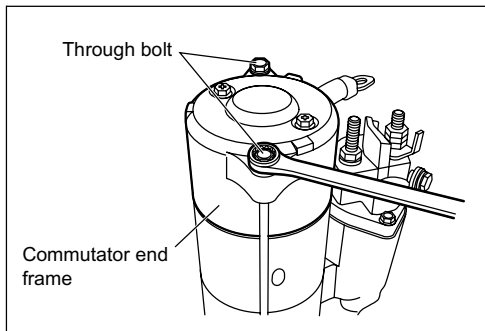

SAPH300021300003

2. Removal of commutator end frame

- (1) Loosen and remove two through bolts.

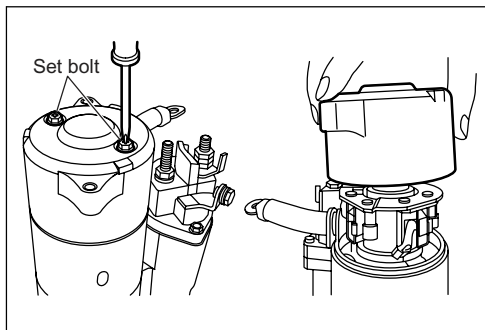

SAPH300021300004

- (2) Remove two set bolts and remove the commutator end frame.

CAUTION • Hold the M lead wire and remove the commutator end frame by lifting.

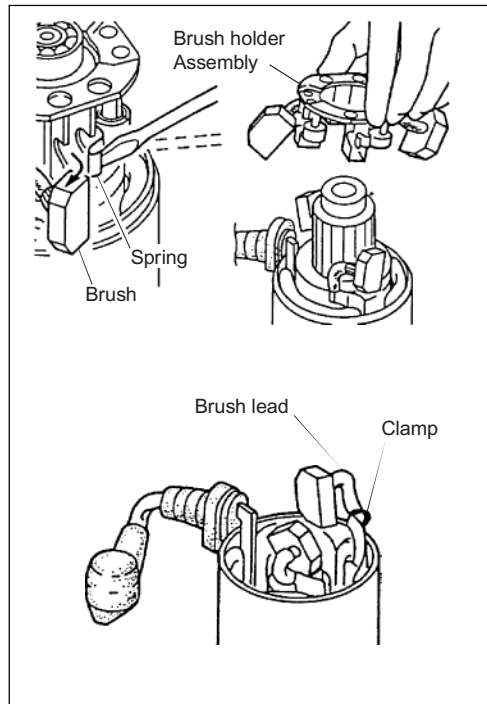

SAPH300021300005

3. Removal of brush holder assembly

- (1) Lift the spring using a flat tip screwdriver or pliers. Remove four brushes from the brush holder assembly.

⚠ CAUTION • Do not cut the brush lead fixing clamp.

- (2) Remove the brush holder assembly from the armature assembly.

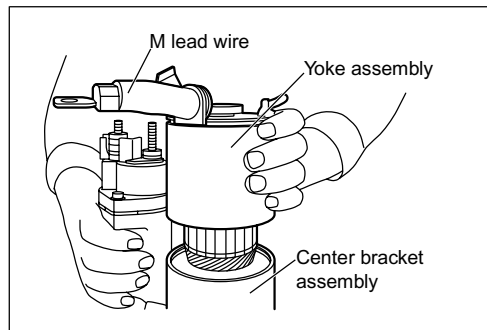

SAPH300021300006

4. Removal of yoke assembly

- (1) Remove the yoke assembly from the center bracket assembly.

⚠ CAUTION • Do not hold the M lead wire and hold the yoke assembly outer diameter for removal.

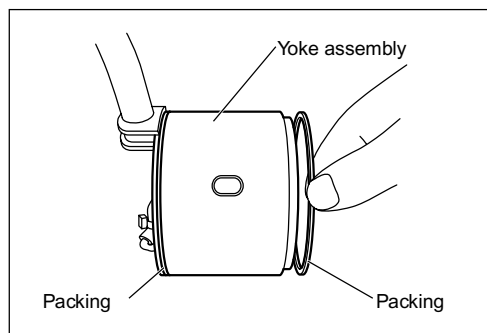

SAPH300021300007

5. Removal of packing

- (1) Remove the packing from the centering parts at both ends of the yoke assembly.

⚠ CAUTION • Damaged packing must not be reused. Replace it with a new part.

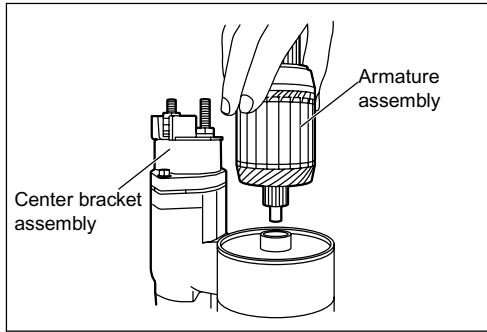

SAPH300021300008

6. Removal of armature assembly

- (1) Remove the armature assembly by lifting.

⚠ CAUTION • When the armature assembly is removed, the washer at the end of the gear may be dropped and lost. Be careful for handling.

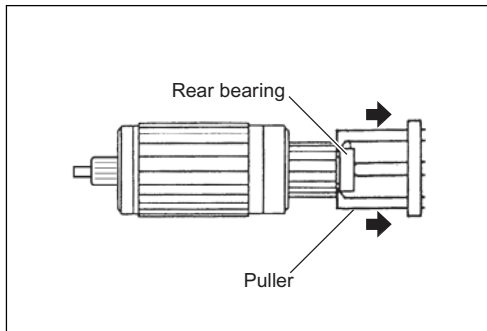

SAPH300021300009

7. Removal of rear bearing

- (1) Pull out the bearing of the armature assembly using a puller or press.

⚠ CAUTION • Removed bearing must not be reused. Replace it with a new one.

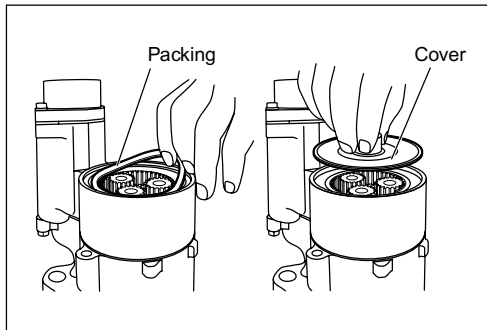

SAPH300021300010

8. Removal of cover

- (1) Remove the cover from the center bracket assembly.
- (2) Remove the packing.

⚠ CAUTION • Damaged packing must not be reused. Replace it with a new part.

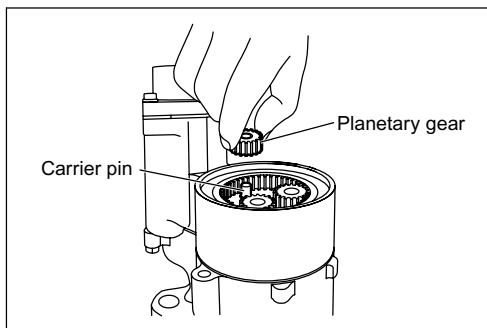

SAPH300021300011

9. Removal of planetary gear

- (1) Remove the planetary gear from the carrier pin.

⚠ CAUTION • Make sure that the gear is not damaged or chipped.

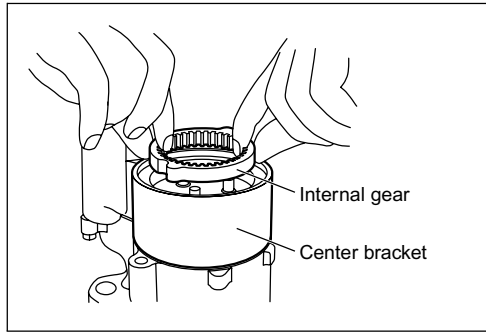

SAPH300021300012

10. Removal of internal gear

- (1) Remove the internal gear from the center bracket.

⚠ CAUTION • Make sure that the gear is not damaged or chipped.

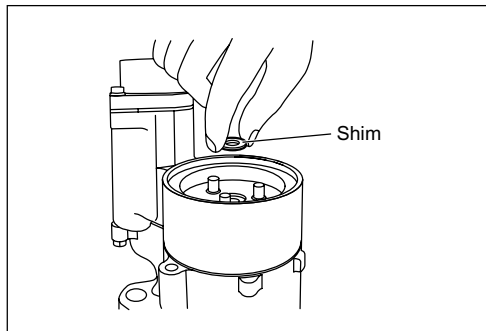

SAPH300021300013

11. Removal of shim washer

- (1) Remove the shim washer from the center bracket.

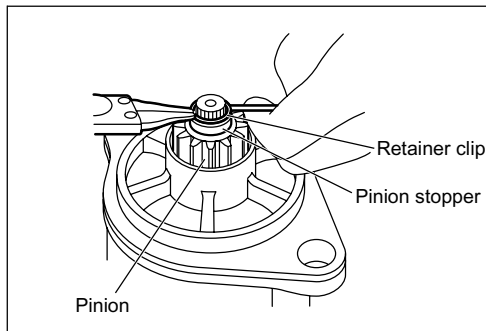

SAPH300021300014

12. Removal of pinion

- (1) Remove the retainer clip using a tool such as snap ring pliers.

⚠ CAUTION • Retainer clip must not be reused. Replace it with a new one.

NOTICE • Push upward or pull out the chipped part of the clip mouth.

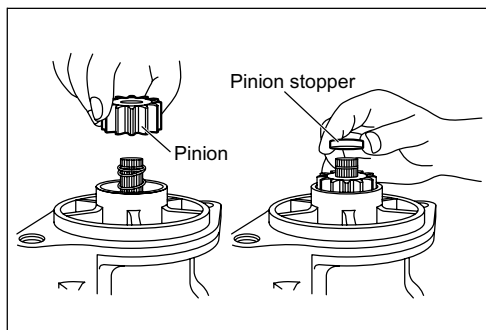

SAPH300021300015

- (2) Remove the pinion stopper.

- (3) Remove the pinion.

⚠ CAUTION • Make sure that the gear is not damaged or chipped.

- (4) Remove the spring.

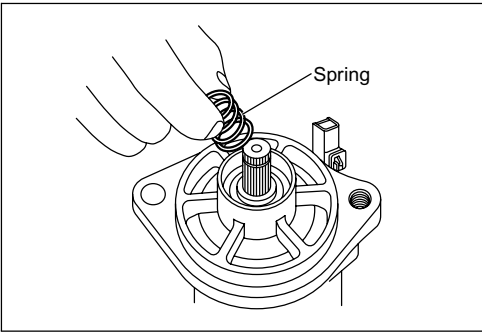

SAPH300021300016

13. Removal of center bracket

- (1) Remove two set bolts at the switch using a box screwdriver or offset wrench.
- (2) Lift and remove the center bracket.

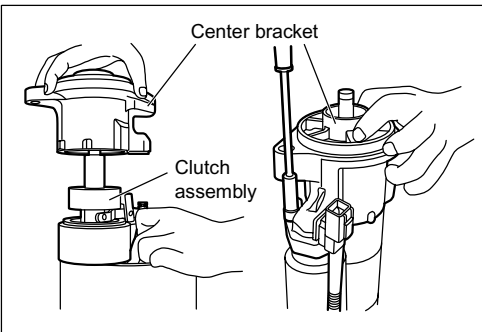

SAPH300021300017

14. Removal of lever

- (1) Hold the lever holder and press the entire lever to the clutch. Remove the link with the plunger.

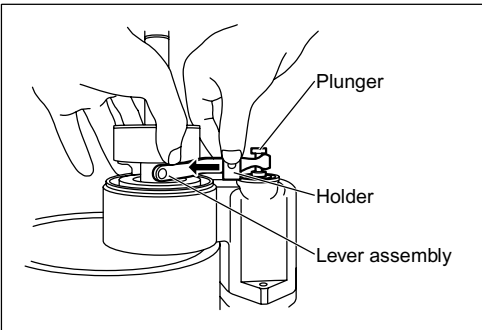

SAPH300021300018

- (2) Turn and pull out the lever assembly using the clutch as the axis.

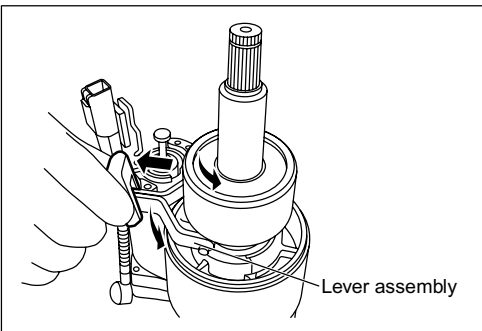

SAPH300021300019

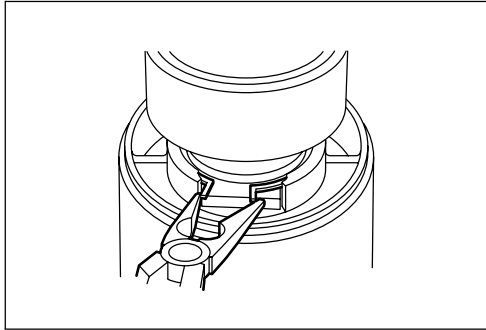

SAPH300021300020

15. Removal of brake plate

- (1) Hold the clutch case outer diameter and slide the clutch assembly upward. Pinch the clip end fixing the brake plate and remove it by bending.

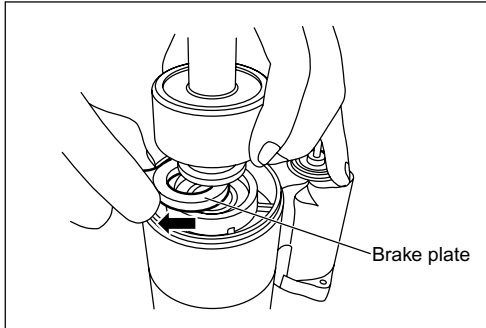

SAPH300021300021

- (2) Remove the brake plate.

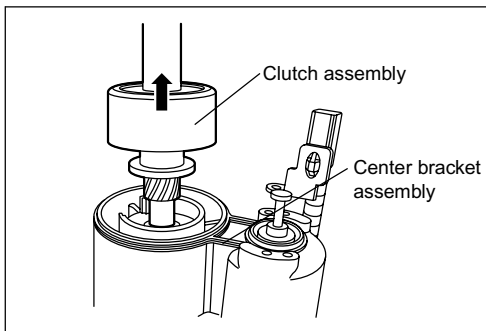

SAPH300021300022

16. Removal of clutch assembly

- (1) While pressing the clutch assembly to the center bracket assembly, offset the helical spline by one tooth. Pull out the clutch assembly upward from the offset position and remove it.

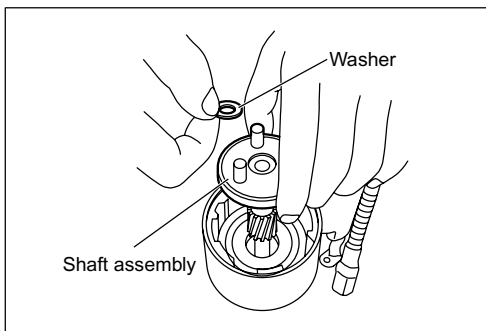

SAPH300021300023

17. Removal of shaft assembly

- (1) Turn the center bracket assembly upside down. Hold the carrier plate and pull out the shaft assembly.

⚠ CAUTION • Washers are available at the upper and lower parts of the carrier plate. Be careful for loss of the washers.

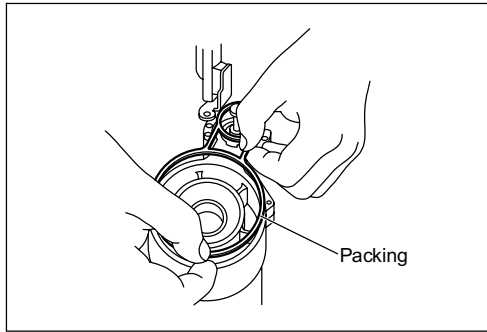

SAPH300021300024

18. Removal of packing

- (1) Turn the center bracket upside down again and remove the packing.

⚠ CAUTION • Packing must not be reused.

Inspection of components

JP30002130703001

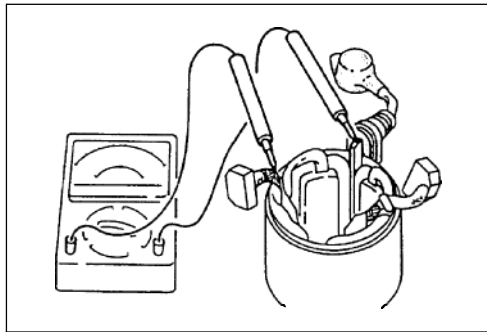

SAPH300021300025

1. Inspection of yoke assembly

- (1) Make sure that the coil lead wire has electric continuity using a circuit tester.
- (2) Make sure that there is no discoloration at the coil.

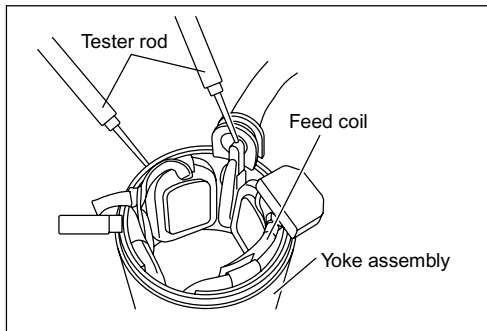

SAPH300021300026

- (3) Measure the resistance between the coil lead wire and the yoke with a circuit tester and check insulation. When the value is below the service limit, replace it.

Service limit	1kΩ or less
----------------------	--------------------

⚠ CAUTION • After cleaning and drying, take measurements.

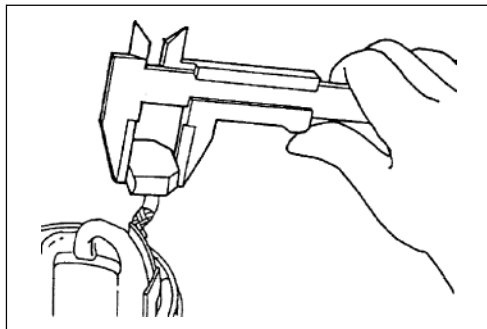

SAPH300021300027

- (4) Measure the brush length using vernier calipers.

Standard value (mm{in.})	Service limit (mm{in.})
18{0.7087}	13{0.5118} or less

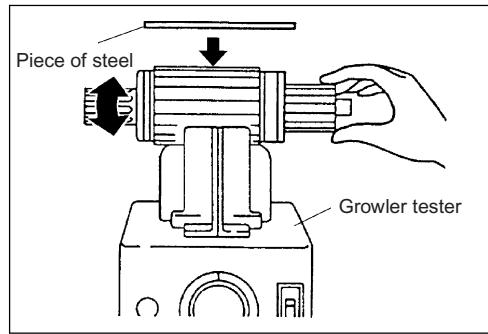

SAPH300021300028

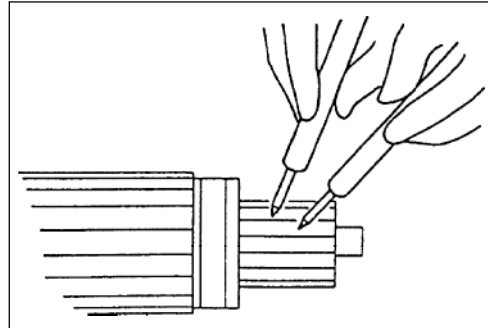

SAPH300021300029

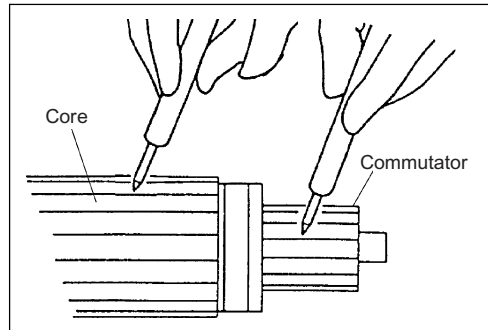

SAPH300021300030

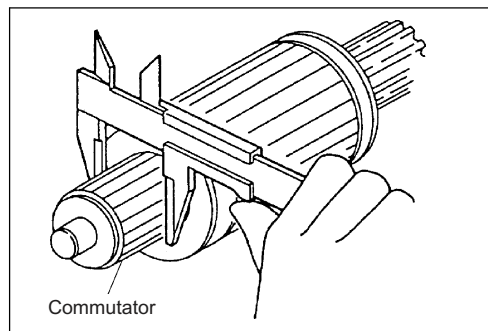

SAPH300021300031

2. Inspection of armature assembly

(1) Turn the armature assembly using a commercially available growler tester and put a piece of steel on the armature assembly. Make sure that the steel piece is not vibrating on the core circumference.

(2) Make sure that adjacent segments of the commutator have electric continuity using a circuit tester.

(3) Make sure that there is no discoloration at the coil.

(4) Measure the resistance between the commutator and the core using a circuit tester and check insulation.

Standard value	Service limit
1MΩ or more	1kΩ or less

⚠ CAUTION • After cleaning and drying, take measurements.

(5) Measure the commutator outer diameter using vernier calipers.

⚠ CAUTION • After removing roughness on the surface (after polishing), take measurements.

Commutator outer diameter

Standard value (mm{in.})	Service limit (mm{in.})
36{1.4173}	34{1.3386} or less

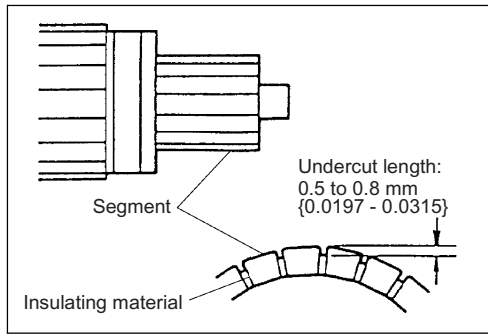

SAPH300021300032

- (6) Measure the undercut depth between segments. If the undercut depth is beyond the service limit, repair it.

Standard value (mm{in.})	Service limit (mm{in.})
0.5 - 0.8{0.0197 - 0.0315}	0.2{0.0079} or less

CAUTION • In repair, do not leave insulation material at the end of the segment.

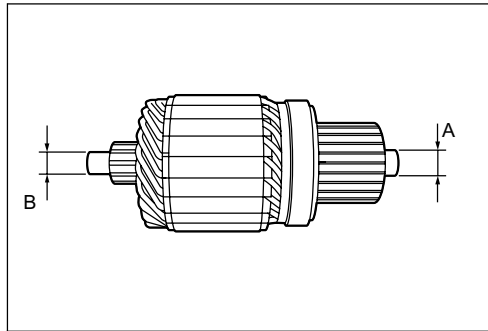

SAPH300021300033

- (7) Measure the shaft outer diameter using a micrometer. If it is beyond the service limit, replace the shaft.

Measuring area	Standard value (mm{in.})	Service limit (mm{in.})
Area	12{0.4724}	11.98{0.4717} or less
Area	9{0.3543}	8.98{0.3535} or less

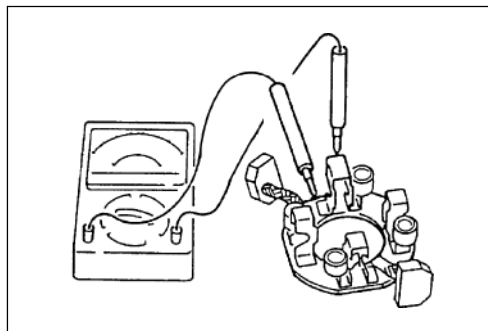

SAPH300021300034

3. Inspection of brush holder assembly

- (1) Measure the resistance between the holder (plus) and the plate using a circuit tester and check insulation. When the value is below the service limit, replace it.

Service limit	1kΩ or less
---------------	-------------

CAUTION • After cleaning and drying, take measurements.

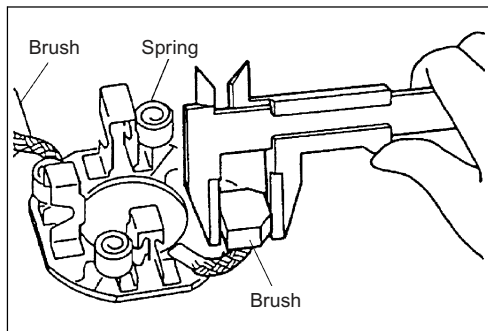

SAPH300021300035

- (2) Measure the brush length using vernier calipers.

Standard value (mm{in.})	Service limit (mm{in.})
18{0.7087}	13{0.5118} or less

- (3) Make sure that the spring has pressure.

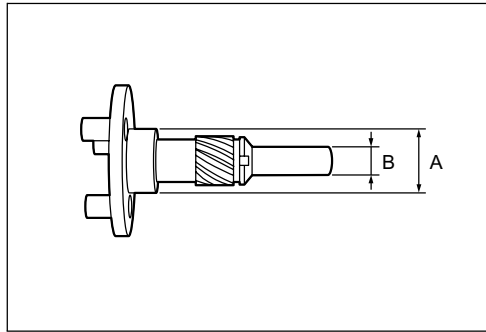

SAPH300021300036

4. Inspection of shaft assembly

- (1) Measure the outer diameter of the shaft using a micrometer
If it is beyond the service limit, replace the shaft.

Measuring area	Standard value (mm{in.})	Service limit (mm{in.})
Area	26{1.0236}	25.90{1.0197} or less
Area	12.1{0.4764}	12.04{0.4740} or less

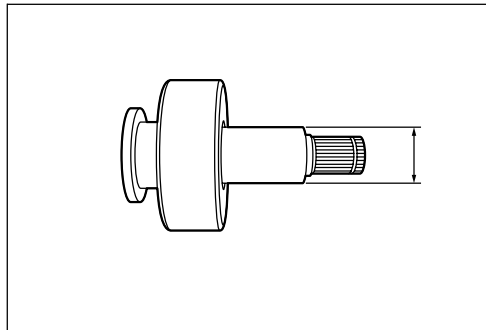

SAPH300021300037

5. Inspection of clutch assembly

- (1) Measure the outer diameter of the inner sleeve using a micrometer.

Standard value (mm{in.})	Service limit (mm{in.})
25{0.9843}	24.90{0.9803} or less

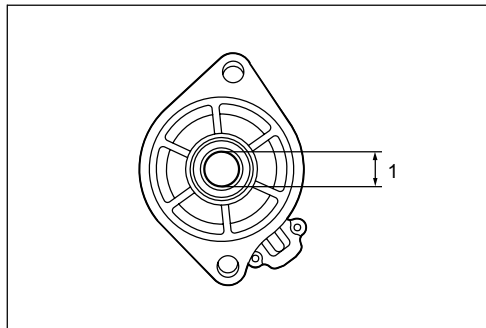

SAPH300021300038

6. Inspection of bearing

- (1) Measure the bearing metal inner diameter (1 in the figure) of the pinion case using a cylinder gauge. If it is beyond the service limit, replace the bushing.

Standard value (mm{in.})	Service limit (mm{in.})
25{0.9843}	25.2{0.9921} or more

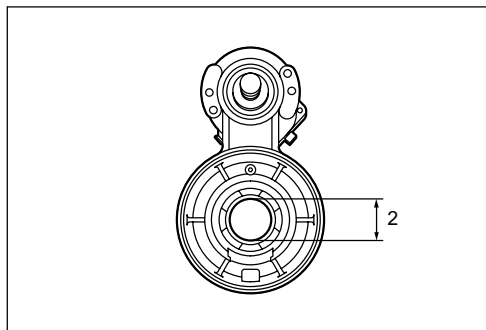

SAPH300021300039

- (2) Measure the bearing metal inner diameter (2 in the figure) of the center bracket using a cylinder gauge. If it is beyond the service limit, replace the center bracket.

Standard value (mm{in.})	Service limit (mm{in.})
26{1.0236}	26.2{1.0315}

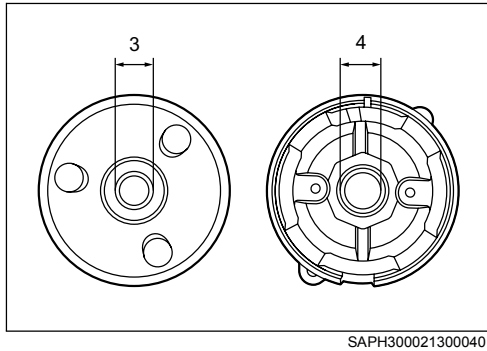

- (3) Measure the bearing metal inner diameter (3 in the figure) of the shaft assembly using a cylinder gauge. If it is beyond the service limit, replace the shaft assembly.

Standard value (mm{in.})	Service limit (mm{in.})
9{0.3543}	9.2{3.6220}

- (4) Measure the bearing housing inner diameter (4 in the figure) of the commutator end frame using a cylinder gauge. If it is beyond the service limit, replace the commutator end frame.

Standard value (mm{in.})	Service limit (mm{in.})
28{1.1024}	28.1{1.1063} or more

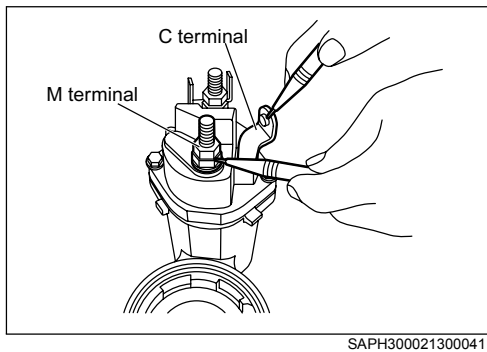

7. Inspection of start magnet switch assembly (resistance of P coil)

- (1) Measure the P coil resistance between the C terminal and the M terminal using a circuit tester.

Standard value (Ω)	0.12 - 0.14

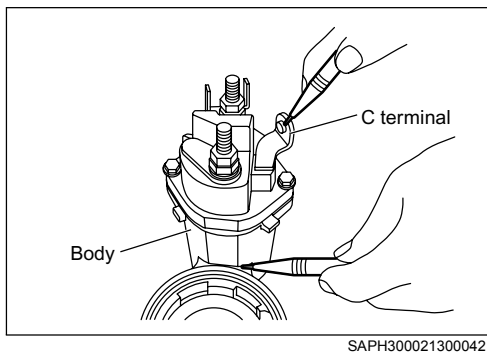

8. Inspection of start magnet switch assembly (resistance of H coil)

- (1) Measure the H coil resistance between the C terminal and the body using a circuit tester.

Standard value(Ω)	1.13 - 1.25

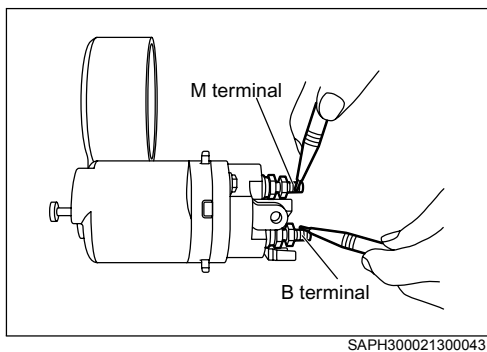

9. Inspection of start magnet switch assembly (electric continuity inspection)

- (1) Check electric continuity between the B terminal and the M terminal using a circuit tester, and make sure that there is no electric continuity.

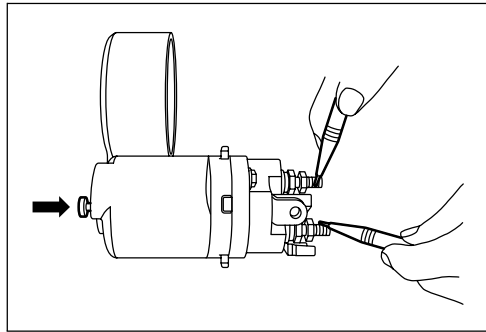

SAPH300021300044

- (2) Push the end of the start magnet switch assembly (close the internal contact) and make sure that there is electric continuity between the B terminal and the M terminal using a circuit tester.

Assembly

JP30002130702002

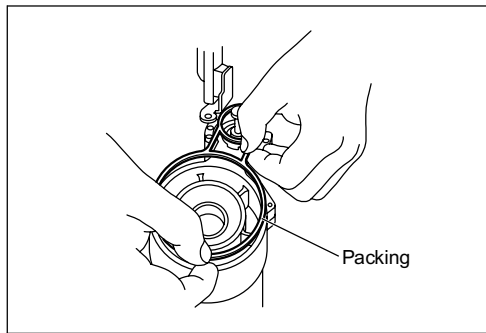

SAPH300021300024

1. Installation of packing

- (1) Install a new packing on the center bracket assembly.

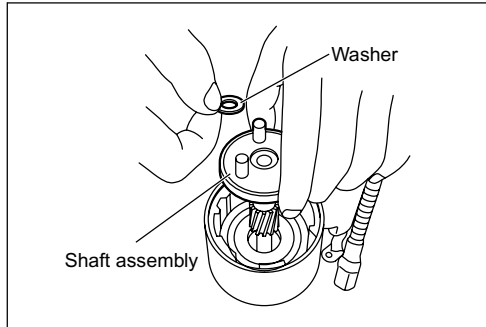

SAPH300021300023

2. Installation of shaft assembly

- (1) Turn the center bracket assembly upside down and hold the carrier plate. Lubricate parts (refer to the lubrication point drawing and the lubrication list) and install the shaft assembly.

⚠ CAUTION • Washers are available at the upper and lower parts of the carrier plate. Be careful for loss of the washers.

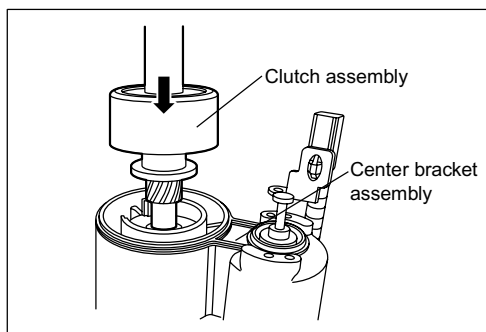

SAPH300021300045

3. Installation of clutch assembly

- (1) Lubricate parts (refer to the lubrication point drawing and the lubrication list) and insert the clutch assembly into the center bracket assembly.

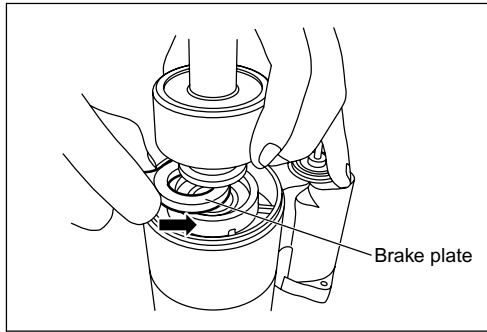

SAPH300021300046

4. Installation of brake plate

- (1) Lubricate parts (refer to the lubrication point drawing and the lubrication list) and install the brake plate.

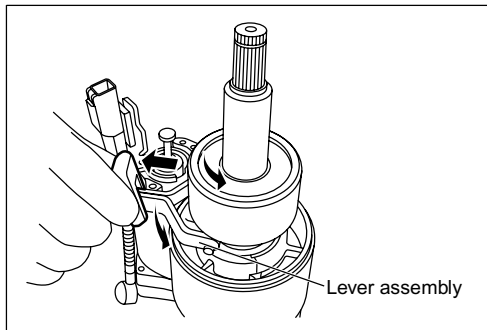

SAPH300021300019

5. Installation of lever

- (1) Lubricate parts (refer to the lubrication point drawing and the lubrication list). Turn and install the lever assembly using the clutch as the axis.

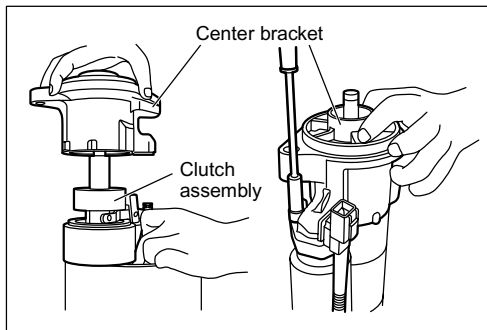

SAPH300021300017

6. Installation of pinion case

- (1) Install two set bolts at the switch using a box screwdriver or offset wrench.

Tightening torque :

14 - 16 N · m {140 - 160 kgf · cm, 10 - 12 lbf · ft}

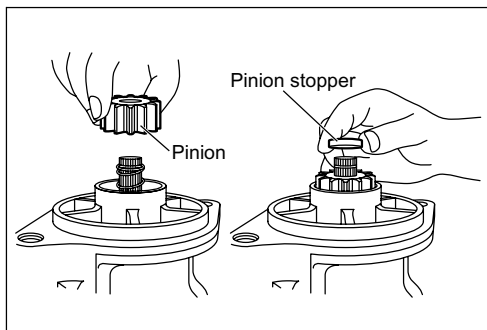

SAPH300021300015

7. Installation of pinion

- (1) Lubricate parts (refer to the lubrication point drawing and the lubrication list) and install the pinion and the pinion stopper.

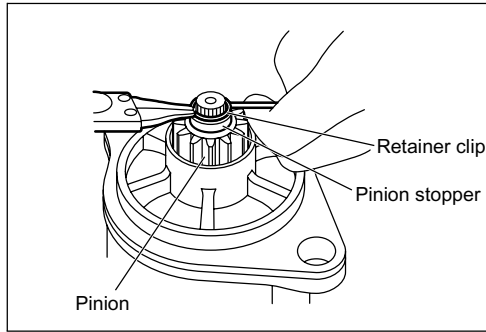

SAPH300021300014

- (2) Install the retainer clip using a tool such as snap ring pliers.

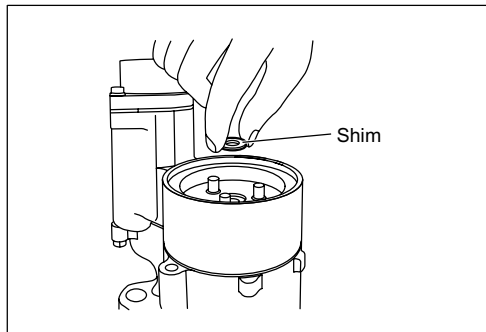

SAPH300021300013

8. Installation of shim washer

- (1) Lubricate parts (refer to the lubrication point drawing and the lubrication list) and install the shim washer on the center bracket.

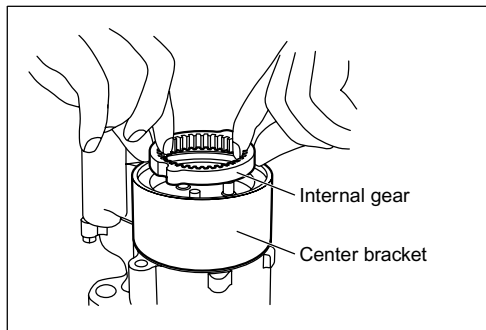

SAPH300021300012

9. Removal of internal gear

- (1) Lubricate parts (refer to the lubrication point drawing and the lubrication list) and install the internal gear on the center bracket.

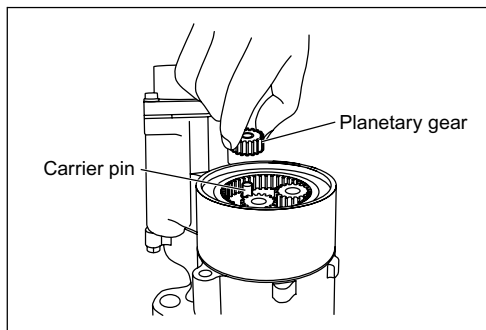

SAPH300021300011

10. Installation of planetary gear

- (1) Lubricate parts (refer to the lubrication point drawing and the lubrication list) and install the planetary gear on the carrier pin.

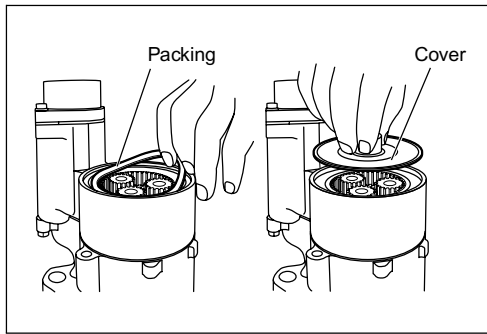

SAPH300021300010

11. Installation of cover

- (1) Install a new packing.
- (2) Install the cover on the center bracket assembly.

12. Installation of rear bearing

- (1) Install the bearing on the armature assembly using a press.

⚠ CAUTION • When the bearing is removed, replace it with a new one.

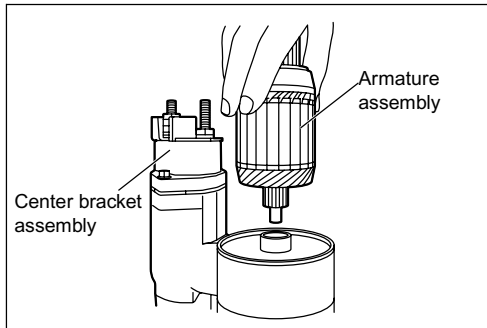

SAPH300021300008

13. Installation of armature assembly

- (1) Install the armature assembly.

⚠ CAUTION • When the armature assembly is installed, the washer at the end of the gear may be dropped and lost. Be careful for handling.

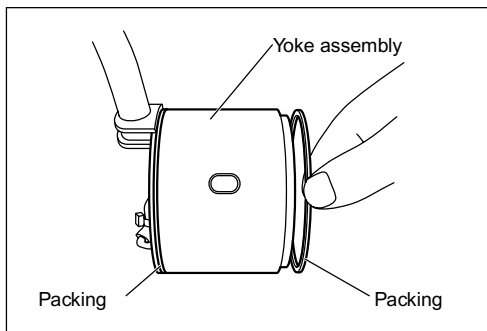

SAPH300021300007

14. Installation of packing

- (1) Install a new packing on the centering location at both ends of the yoke assembly.

⚠ CAUTION • Damaged packing must not be reused. Replace it with a new part.

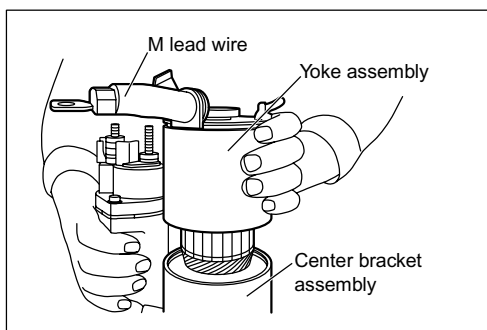

SAPH300021300006

15. Installation of yoke assembly

- (1) Install the yoke assembly on the center bracket assembly.

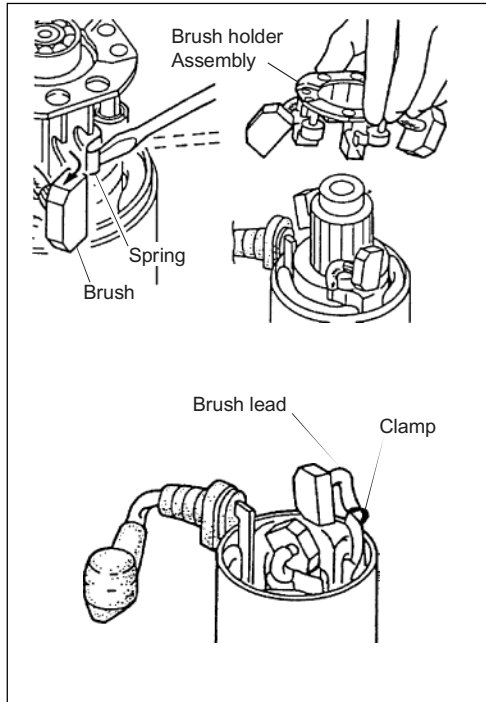

SAPH300021300005

16. Installation of brush holder assembly

- (1) Lift the spring using a flat tip screwdriver, long-nose pliers or pliers. Install four brushes on the brush holder assembly.

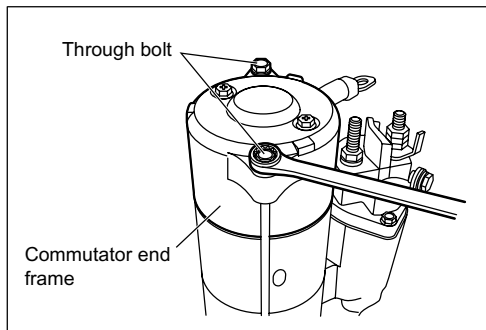

SAPH300021300003

17. Installation of commutator end frame

- (1) Tighten the through bolt of the commutator end frame.

Tightening torque :

15.7 - 17.6 N · m {160 - 179 kgf · cm, 12 - 13 lbf · ft}

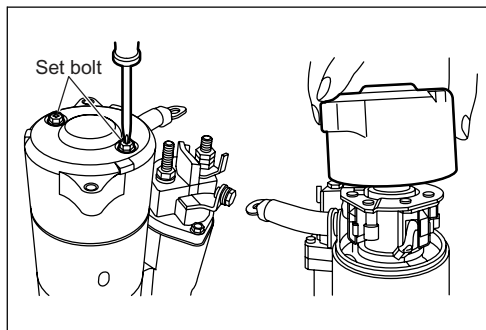

SAPH300021300004

- (2) Tighten two set bolts.

Tightening torque :

3.6 - 4.9 N · m {37 - 49 kgf · cm, 3 - 4 lbf · ft}

⚠ CAUTION • Hold the M lead wire and remove the commutator end frame by lifting.

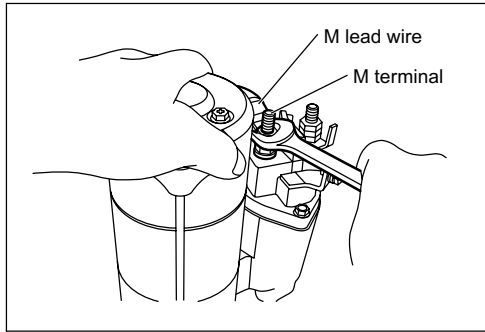

SAPH300021300002

18. Installation of lead wire

- (1) Install the M lead wire.

19. Lubrication

Refer to the following figure and table for lubricant to be applied.

CAUTION • There shall be no lubricant on the commutator surface, brush and contact.

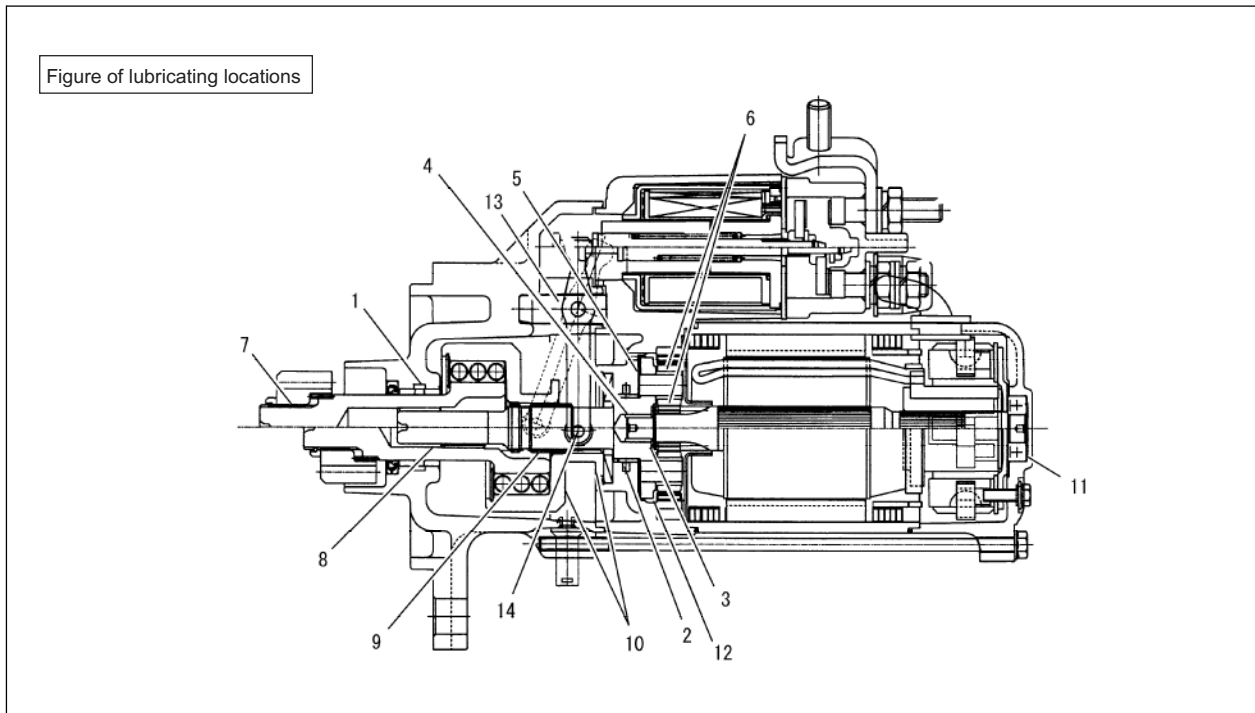

SAPH300021300047

Table of lubricant

Code	Lubricating point	Lubricant used	Amount (g{oz})	Remark	Lubricant manufacturer
1	Pinion case metal and grease reservoir	Multemp AC-N	0.8 - 1.5 {0.03 - 0.05}		Kyodo Yushi
2	Bracket center metal and grease reservoir	Multemp AC-N	0.5 - 1.5 {0.03 - 0.05}		Kyodo Yushi
3	Shim washer	Multemp AC-N	0.2 - 0.5 {0.01 - 0.02}	Applied to both sides of washer.	Kyodo Yushi
4	Armature front metal	Multemp AC-N	0.5 - 1 {0.02 - 0.04}		Kyodo Yushi
5	Shim washer	Multemp AC-N	0.2 - 0.5 {0.01 - 0.02}	Applied to both sides of washer.	Kyodo Yushi
6	Internal gear	Multemp AC-N	7 - 11 {0.25 - 0.39}		Kyodo Yushi
	Armature gear				
	Planetary gear				
7	Pinion straight Spline	Multemp AC-N	0.5 - 1 {0.02 - 0.04}		Kyodo Yushi
8	Inner sleeve metal	Multemp AC-N	0.3 - 0.6 {0.01 - 0.02}		Kyodo Yushi
9	Helical spline	Multemp AC-N	0.5 - 1 {0.02 - 0.04}		Kyodo Yushi
10	Clutch case lever shifter	Pyroknock No.2	1 - 2 {0.04 - 0.07}		Nippon Oil Corporation
11	Bracket rear bearing housing	Pyroknock No.2	0.2 - 0.5 {0.01 - 0.02}		Nippon Oil Corporation
12	Planetary gear metal	Multemp AC-N	1 - 2 {0.04 - 0.07}		Kyodo Yushi
13	Lever holder	Multemp AC-N	0.4 - 0.8 {0.01 - 0.03}		Kyodo Yushi
14	Lever roller rod	Pyroknock No.2	0.2 - 0.5 {0.01 - 0.02}	Assemble the roller after application of grease to prevent fall of the roller in assembly.	Nippon Oil Corporation

Alternator (60A)

Part layout (typical example of 60A)

JP30002130402002

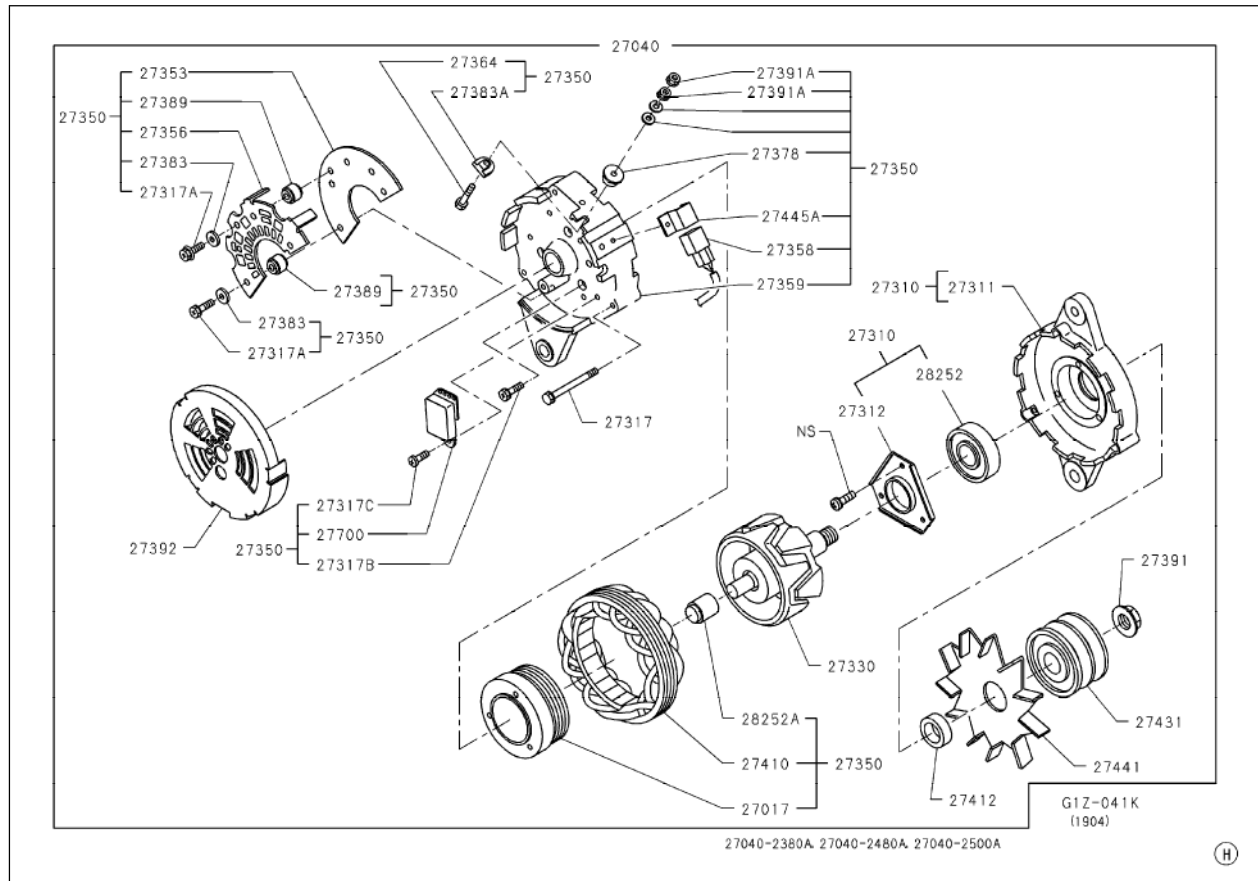

SAPH300021300048

27017	Feed coil	27383A	Insulator
27040	Alternator	27389	Insulator
27310	Drive end frame assembly	27392	Cover
27311	Drive end frame	27410	Stator coil
27312	Bearing cover	27412	Collar
27330	Rotor assembly	27431	Pulley
27350	End frame assembly	27441	Fan
27353	Rectifier minus	27445A	Coupler holder
27356	Rectifier plus	27700	Regulator
27359	End frame	28252	Front bearing
27383	Insulator	28252A	Rear bearing

Tightening torque

27317	7.8-9.8 N·m {80-99 kgf·cm, 6-7lbf·ft}	27317C	1.9-2.5 N·m {20-25 kgf·cm, 1-2lbf·ft}
27317A	1.9-2.5 N·m {20-25 kgf·cm, 1-2lbf·ft}	27391	127 - 157 N·m {1,300 - 1,600 kgf·cm, 94-116lbf·ft}
27317B	2.9 - 3.9 N·m {30 - 39 kgf·cm, 2-3lbf·ft}	27391A	Internal nut : 4.9-5.9 N·m {50-60 kgf·cm, 3.6-4.3lbf·ft}

Circuit drawing (60A)

JP30002130803001

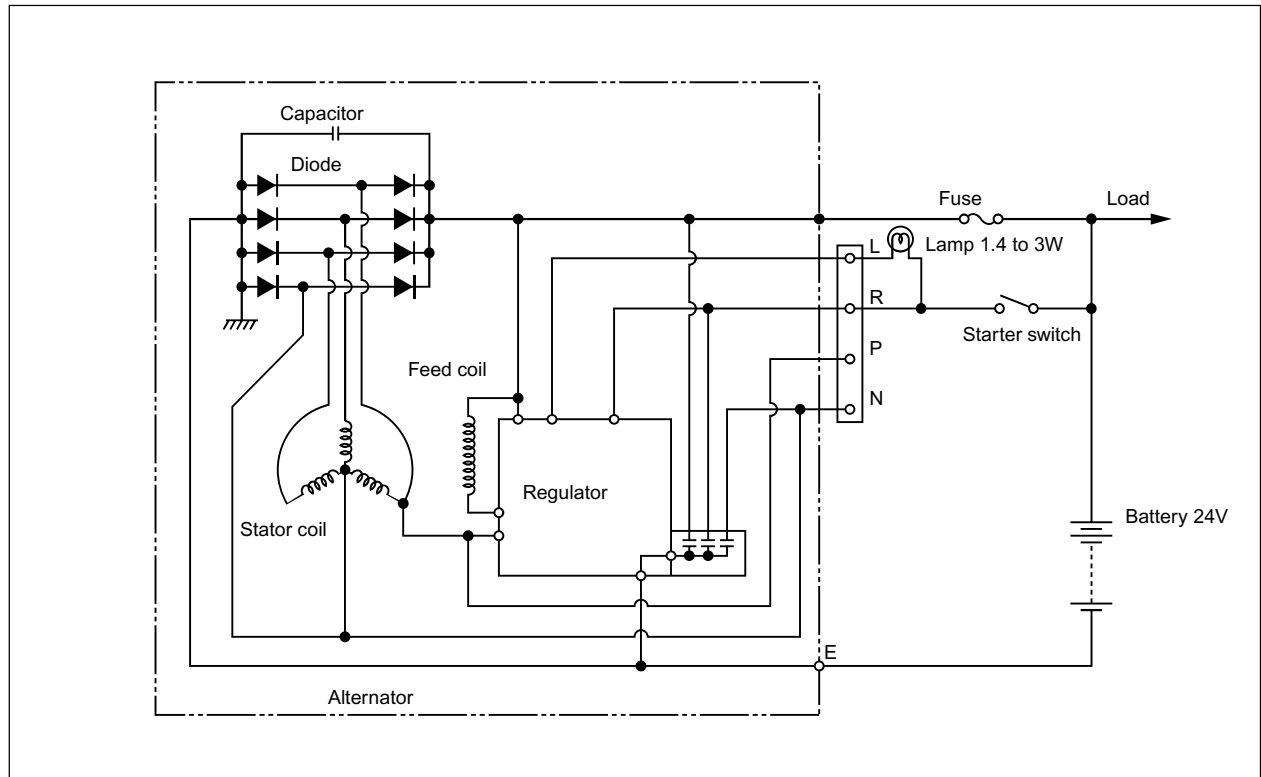

SAPH300021300049

Disassembly (60A)

JP30002130702003

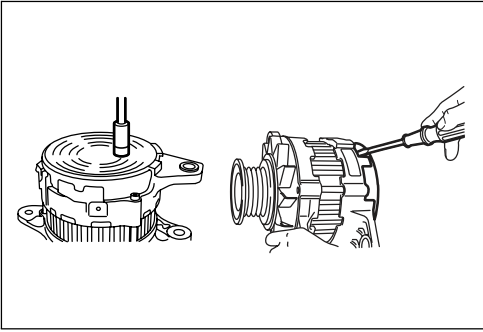

SAPH300021300050

⚠ CAUTION • Place a rubber mat and perform work on the mat.

1. Disconnection of front from rear

- (1) Remove fixing bolts and remove the cover.

⚠ CAUTION • Press the tabs of the cover for removal. Be careful not to break the tab with excessive force.

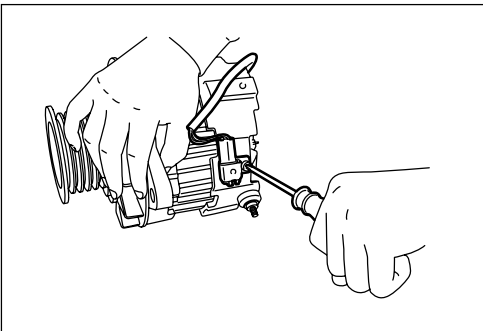

SAPH300021300051

- (2) Remove bolts with a screwdriver and remove the coupler holder.

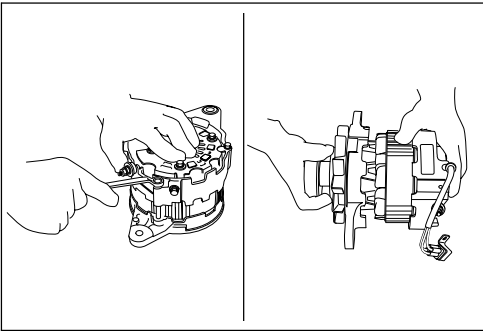

SAPH300021300052

- (3) Remove three through bolts and disconnect the front from the rear.

2. Disassembly of front

- (1) Remove nuts and remove the pulley, fan and collar.

⚠ CAUTION • Tie around a general V-belt in the pulley groove and fix the pulley with a vice.

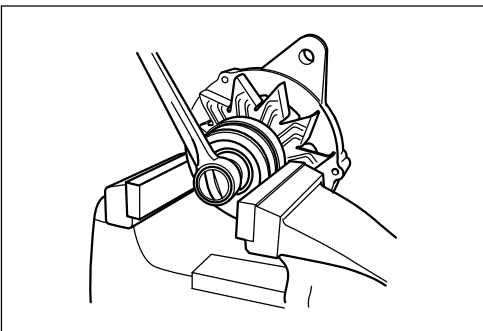

SAPH300021300053

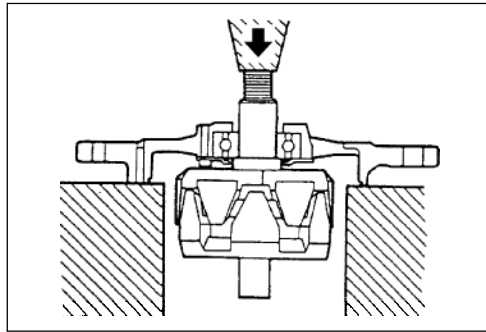

SAPH300021300054

- (2) Remove the rotor assembly using a press.

- CAUTION**
- Do not damage the end of the thread.
 - Support the rotor assembly to prevent fall of the rotor assembly.

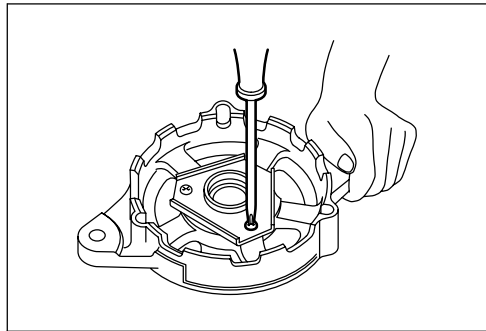

SAPH300021300055

- (3) Remove three bolts with a screwdriver and remove the bearing cover.

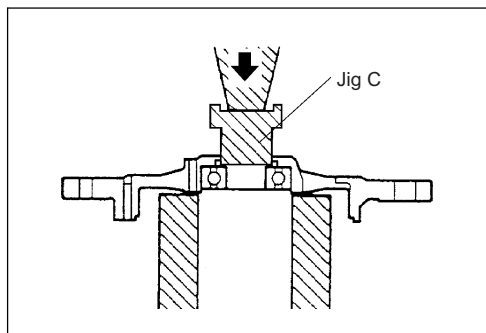

SAPH300021300056

- (4) Remove the ball bearing from the front bracket using a press or jig C.

- CAUTION**
- Place jig C at the inner race of the front bearing.
 - Removed bearing must not be reused.

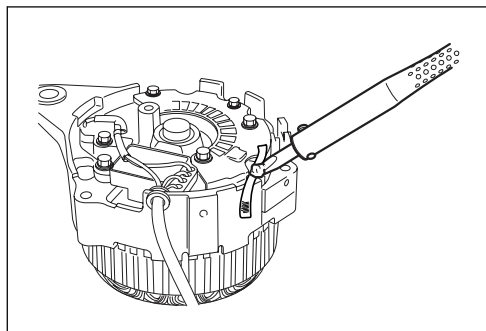

SAPH300021300057

3. Disassembly of rear

- (1) Remove solder of the lead wire connecting the stator coil and the diode using a soldering bit and suction line or a solder suction device

- CAUTION**
- At solder of the stator coil and the diode, the end of the diode is clamped. Do not damage the diode by prying. Deformed diode must not be reused.
 - Perform soldering in a short time (within 5 seconds).

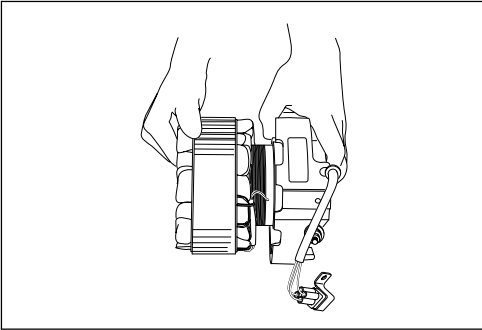

SAPH300021300058

(2) Remove the stator coil from the rear bracket.

CAUTION • Do not damage the stator coil.

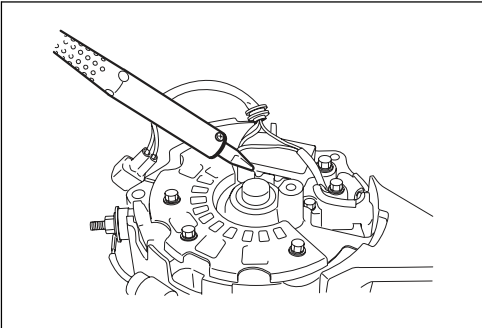

SAPH300021300059

(3) Remove solder of the lead wire connecting the regulator and the field coil using a soldering bit.

CAUTION • Remove the lead wire of the field coil by raising the terminal of the regulator.
• Perform soldering in a short time (within 5 seconds).

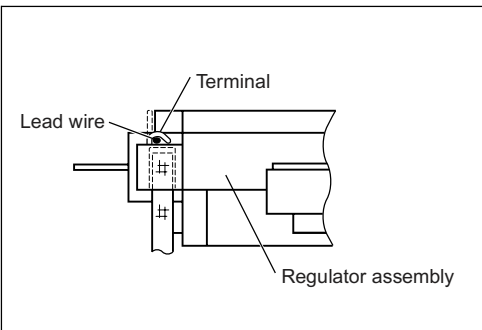

SAPH300021300060

(4) Loosen the nut at the B terminal.

CAUTION • Loosen the nut to some extent and do not remove it from the B terminal.

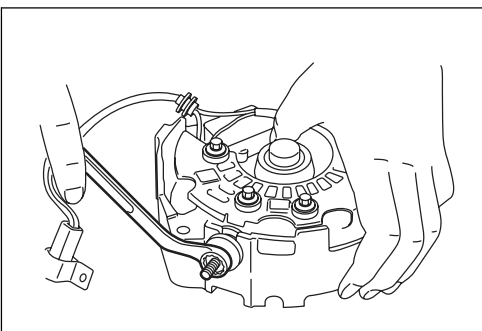

SAPH300021300061

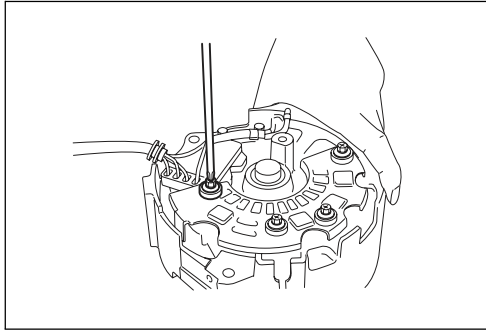

SAPH300021300062

- (5) Remove five bolts using a screwdriver and remove the heat sink assembly (plus), heat sink assembly (minus) and regulator all together.

- ⚠ CAUTION**
- **Screw lock is used. Since torque is high until bolt is removed, be careful not to damage the groove of the bolt head.**
 - **When the rear bracket is reused, clean the screw hole.**

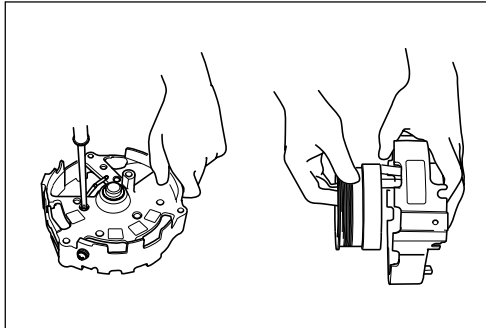

SAPH300021300063

- (6) Remove the capacitor.
 (7) Remove three bolts with a screwdriver and remove the field coil from the rear bracket.

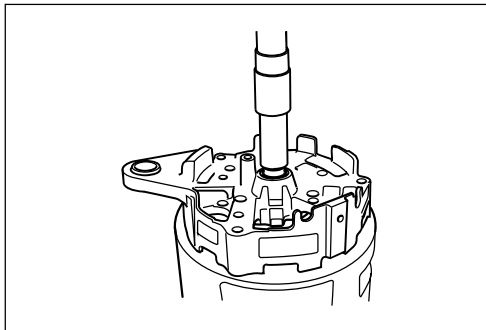

SAPH300021300064

- (8) Remove the roller bearing from the rear bracket using a press, jig A and jig B.

- ⚠ CAUTION**
- **Removed bearing must not be reused.**

Inspection of components (60A)

JP30002130703002

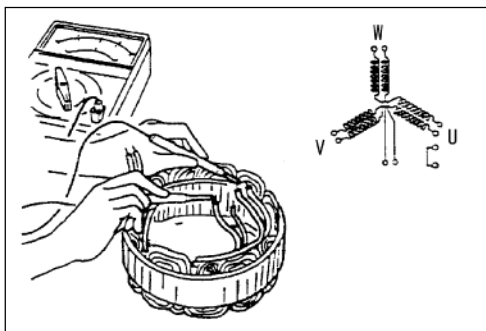

SAPH300021300065

- ⚠ CAUTION**
- **Place a rubber mat and perform work on the mat.**

1. Inspection of stator coil and field coil

- (1) Measure the resistance between U-V, V-W and W-U terminals of the stator coil using a circuit tester.

Standard value (Ω)	0.15 - 0.17

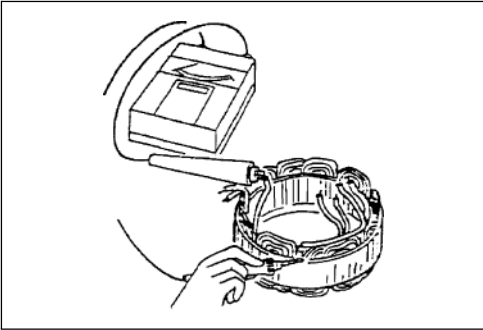

SAPH300021300066

- (2) Measure the resistance between the stator coil core and each terminal using a megger tester.

Standard value (MΩ)	1 or more
---------------------	-----------



SAPH300021300067

- (3) Measure the resistance of the field coil using a circuit tester.

Standard value (Ω)	6.4 - 7.0
----------------------	-----------

- ⚠ CAUTION**
- Do not damage the circumferential surface of the coil.
 - Damaged coil circumference must not be reused.

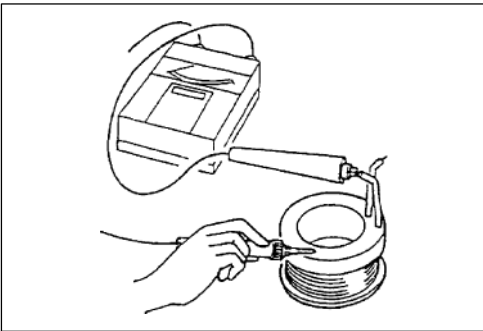

SAPH300021300068

- (4) Measure the resistance between the core and the coil using a megger tester.

Standard value (MΩ)	1 or more
---------------------	-----------

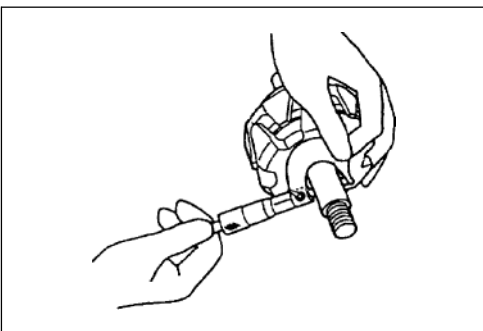

SAPH300021300069

2. Inspection of rotor assembly

- (1) Measure the outer diameter of the shaft at the ball bearing insertion area of the rotor assembly using a micrometer.

Standard value (mm{in.})	25{0.9843}
Service limit (mm{in.})	24.98{0.9835}

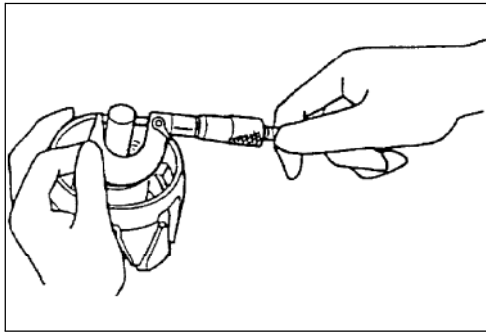

SAPH300021300070

- (2) Measure the outer diameter of the shaft at the roller bearing insertion area of the rotor assembly using a micrometer.

Standard value (mm{in.})	17{0.6693}
Service limit (mm{in.})	16.98{0.6685}

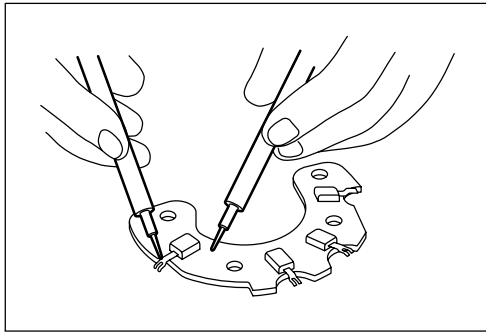

SAPH300021300071

3. Inspection of diode, capacitor and regulator

- (1) Measure the resistance of the holder between the minus diode and the heat sink holder using a circuit tester.

	Standard value
Forward resistance value	Approx. 10 Ω
Reverse resistance value	Infinite



SAPH300021300072

- (2) Measure the resistance between the capacitor terminal and the body using a circuit tester. Make sure that it indicates 800 kΩ and then immediately indicates infinite value.

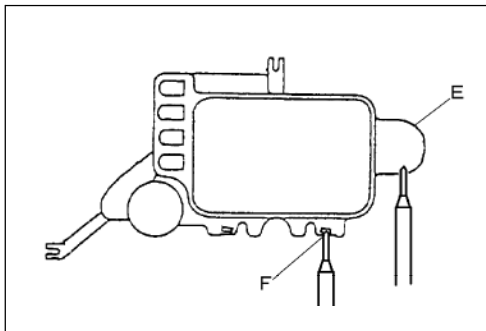

SAPH300021300073

- (3) Inspection of regulator
Measure the resistance between regulator terminals F and E using a circuit tester.

	Standard value
Forward resistance value	Approx. 10 Ω
Reverse resistance value	Infinite

Assembly (60A)

JP30002130702004

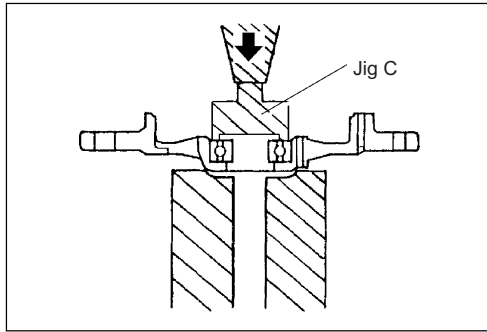

SAPH300021300074

⚠ CAUTION • Place a rubber mat and perform work on the mat.

1. Assembly of front

- (1) Press fit a new ball bearing into the front bracket using a press and jig C.

⚠ CAUTION • Place jig C at the outer race of the ball bearing.

• Removed bearing must not be reused.

- (2) Install the bearing cover with bolts.

Tightening torque :

1.9 - 2.5 N·m {20 - 25 kgf·cm, 1 - 2 lbf·ft}

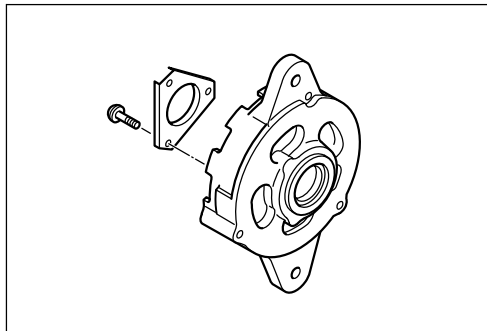

SAPH300021300075

- (3) Install the rotor assembly using a press.

⚠ CAUTION • Be sure to support the inner race of the bearing for press fit of the rotor.

• Do not damage the shaft.

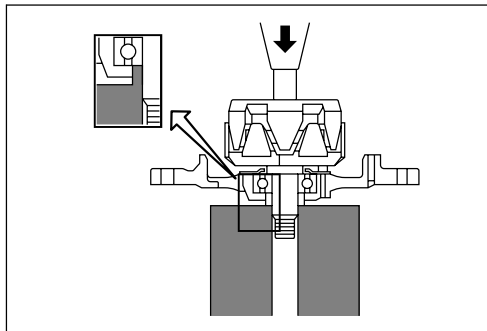

SAPH300021300076

- (4) Install the space collar, fan and pulley on the shaft of the rotor assembly.

Tightening torque :

127 - 157 N·m {1,300 - 1,600 kgf·cm, 94 - 116 lbf·ft}

⚠ CAUTION • Tie around a general V-belt in the pulley groove and fix the pulley with a vice.

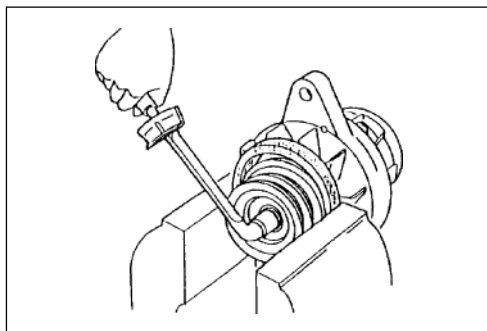

SAPH300021300077

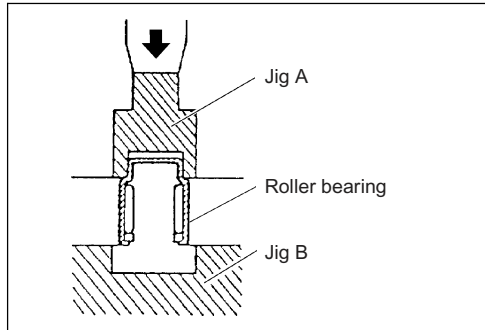

SAPH300021300078

2. Assembly of rear

- (1) Press fit a new roller bearing into the rear bracket using a press, jig A and jig B.

⚠ CAUTION • Press fit until jig A comes in contact with the rear bracket.

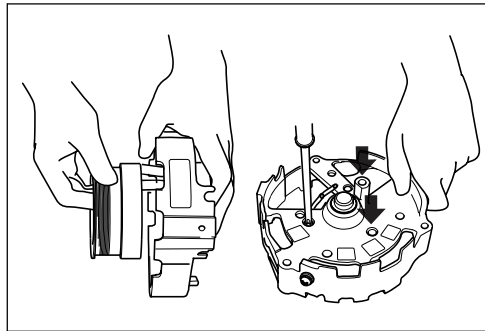

SAPH300021300079

- (2) Install the field coil on the rear bracket.

Tightening torque :

2.9 - 3.9 N · m {30 - 39 kgf · cm, 2 - 3 lbf · ft}

⚠ CAUTION • Tighten bolts finally after temporary tightening. Tighten them evenly.

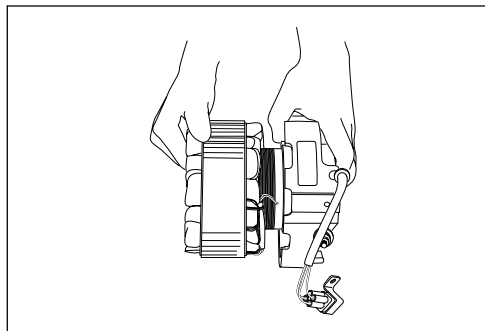

SAPH300021300080

- (3) Assemble the stator coil on the rear bracket temporarily.

⚠ CAUTION • Do not damage the stator coil.

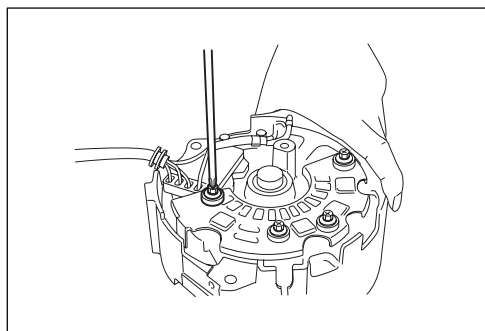

SAPH300021300081

- (4) Install parts referring to the part layout.

Tightening torque :

1.9 - 2.5 N · m {20 - 25 kgf · cm, 1 - 2 lbf · ft}

⚠ CAUTION • Apply screw lock to the ends of the heat sink mounting bolt and the regulator mounting bolt.

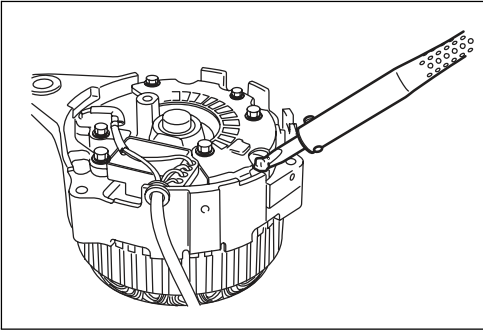

SAPH300021300082

- (5) Solder the lead wire connecting the regulator and the field coil, and connecting the stator coil and the diode using a soldering bit.

- ⚠ CAUTION**
- Perform soldering after tightening of bolts.
 - Bend and fix the regulator terminal before soldering the lead wire of the field coil.
 - Clamp the end of the diode of the stator coil before soldering.
 - Perform soldering in a short time (within 5 seconds).

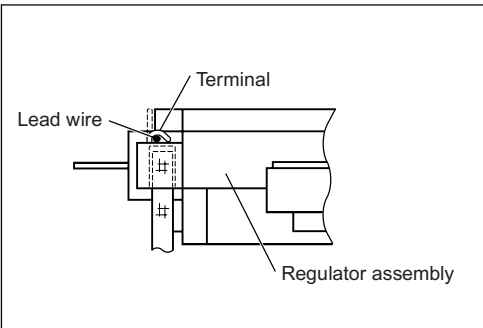

SAPH300021300083

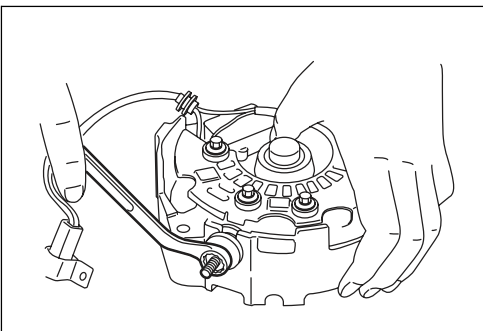

SAPH300021300084

- (6) Tighten the nut inside the B terminal.

Tightening torque :

4.9 - 5.9 N·m {50 - 60 kgf·cm, 3.6 - 4.3 lbf·ft}

- NOTICE**
- After installation of the alternator, connect the wire and tighten the outside nut

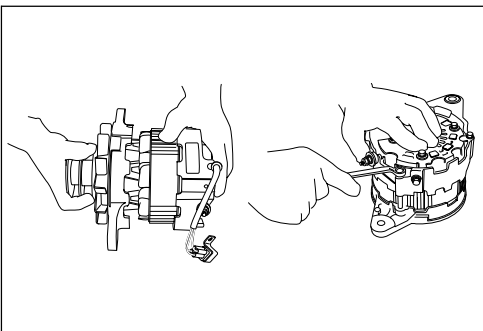

SAPH300021300085

3. Joint of front and rear

- (1) Joint the front with the rear with bolts.

Tightening torque :

7.8 - 9.8 N·m {80 - 99 kgf·cm, 6 - 7 lbf·ft}

- ⚠ CAUTION**
- Tighten bolts evenly.

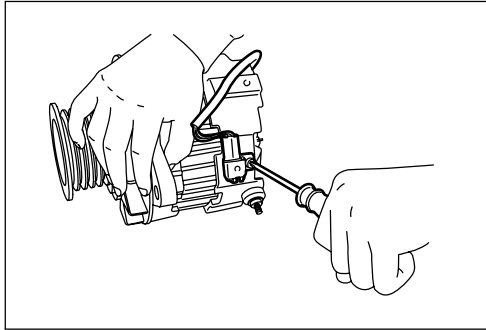

SAPH300021300086

- (2) Install the coupler holder and tighten bolts.

Tightening torque :

1.9 - 2.5 N · m {20 - 25 kgf · cm, 1 - 2 lbf · ft}

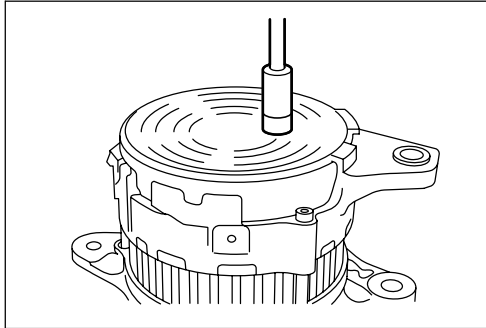

SAPH300021300087

- (3) Align the tab and install the cover. Fix it with bolts.

Tightening torque :

3.3 - 4.4 N · m {34 - 44 kgf · cm, 2 - 3 lbf · ft}

⚠ CAUTION • Do not hit the cover because the tab may be broken.

Inspection after assembly (60A)

JP30002130703003

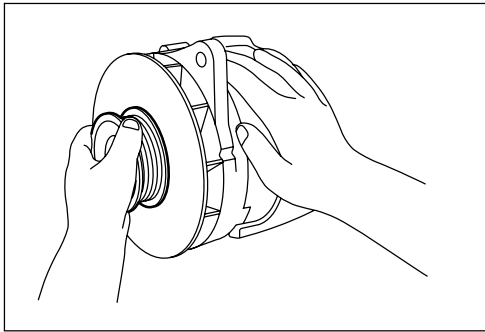

SAPH300021300088

⚠ CAUTION • Place a rubber mat and perform work on the mat.

1. Inspection of rotation

- (1) Turn the pulley with hand to check if there is no interference with internal parts and if rotation is smooth.

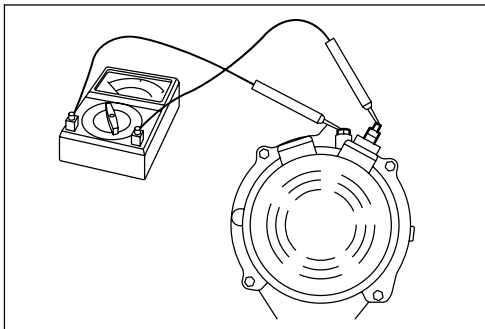

SAPH300021300089

- (2) Measure the resistance between B and E terminals and between P and E terminals using a circuit tester. If it is beyond the standard value (e.g. 0 Ω), disassemble it again and reassemble the unit correctly.

Circuit tester lead		Standard value
(+)	(-)	
B	E	Approx. 20 Ω
E	B	Infinite
P	E	Approx. 7 Ω
E	P	Infinite

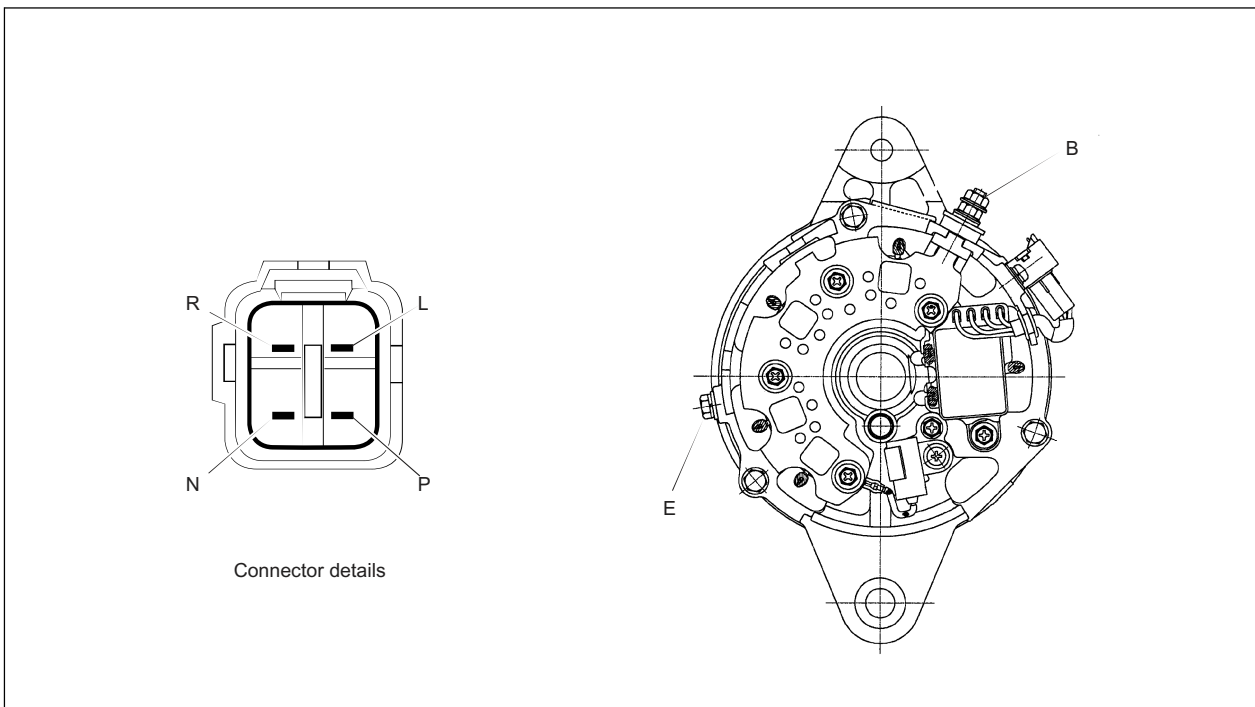

Connector details

SAPH300021300090

14 TURBOCHARGER

Turbocharger Assembly.....	14-2
Part layout.....	14-2
Inspection	14-3
Replacement.....	14-6

Turbocharger Assembly

Part layout

JP3000214040001

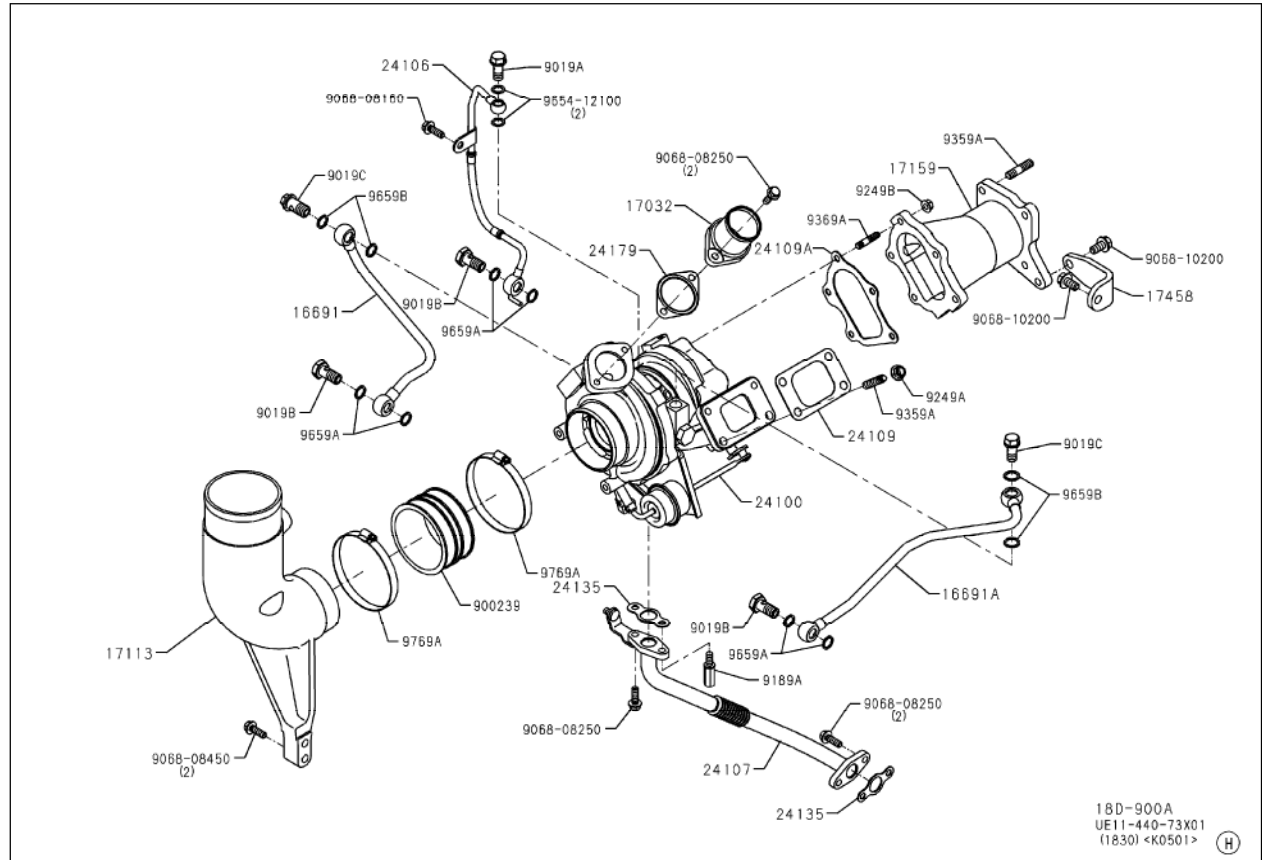
 18D-900A
 UE11-440-73X01
 (1830) <K0501>

SAPH300021400001

16691	Coolant pipe	24109	Gasket*
16691A	Coolant pipe	24109A	Gasket*
17113	Intake pipe	24135	Gasket*
17159	Exhaust manifold connector	24107	Oil outlet pipe
17458	Exhaust pipe bracket	9654-12100	Gasket*
24100	Turbocharger assembly	9659A	Gasket*
24106	Oil inlet pipe	9659B	Gasket*

*Parts not to be reused.

Tightening torque

9249A	56 N·m {570 kgf·cm, 41lb·ft}
-------	------------------------------

Inspection

JP30002140501001

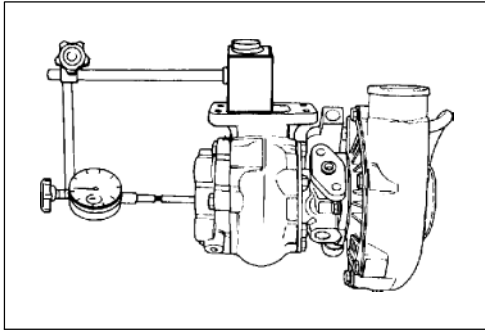

SAPH300021400002

1. Inspection of turbine shaft axial play

- (1) Inspect play of the turbine shaft at the exhaust side using a special tool.

Special tool : 380100044 Tool assembly

- (2) If the measurement value is beyond the standard value, ask the manufacturer to overhaul the unit.

Standard value (mm{in.})	0.040 - 0.085 {0.0016 - 0.0033}
---------------------------------	--

NOTICE

- Since the assembly is replaced, disassembly and inspection are not allowed.

2. Inspection procedure with special tool

- (1) Remove dial gauge (key No. 1), loosen the bolt (key No. 13) of the guide (key No. 13) and turn the guide (key No. 2) 90°. Put the dial gauge into the plate (key No. 8) which is inspected for axial play, and tighten the bolt (key No. 19) for fixing.

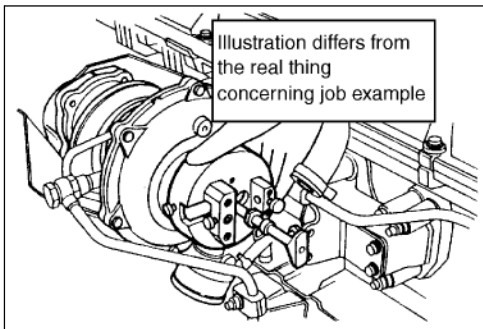

SAPH300021400003

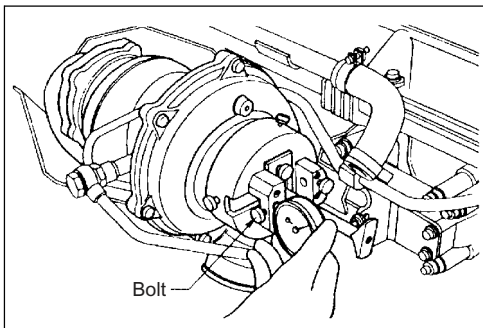

SAPH300021400004

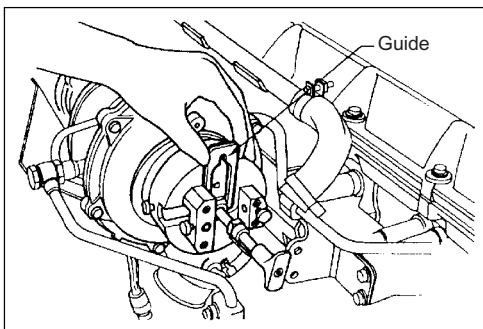

SAPH300021400005

- (2) Insert the guide (key No. 9) to prevent horizontal movement of the measuring instrument.

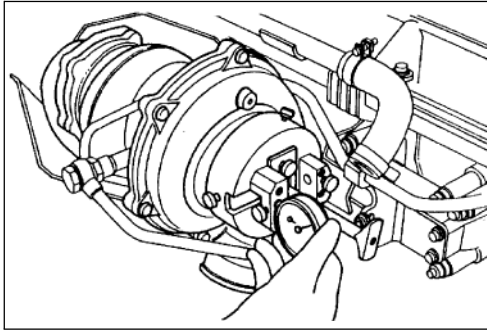

SAPH300021400006

- (3) When the guide (key No. 9) is fixed, move the bar (key No. 4) vertically and fix the guide (key No. 9) with the stopper (key No. 10) so that the needle of the dial gauge may come at the center.

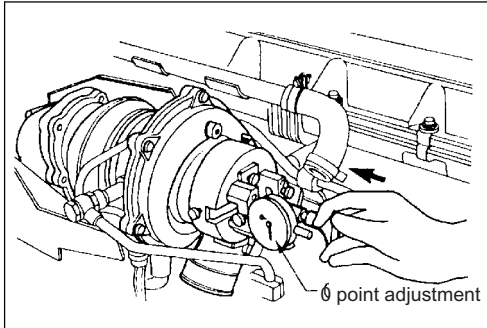

SAPH300021400007

- (4) Hold the puller (key No. 5) and press it toward the turbine in the axial direction. Set the dial gauge reading to 0.

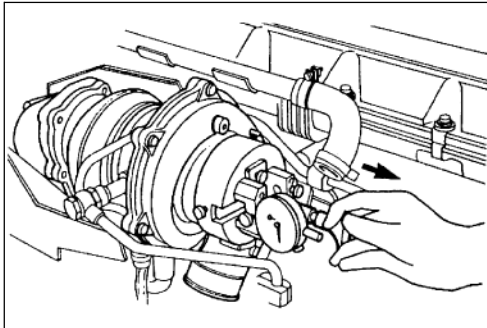

SAPH300021400008

- (5) Pull it to the opposite side and measure movement in the axial direction.
- (6) Take three measurements and use the average value as the measurement value.

Special Tool Details

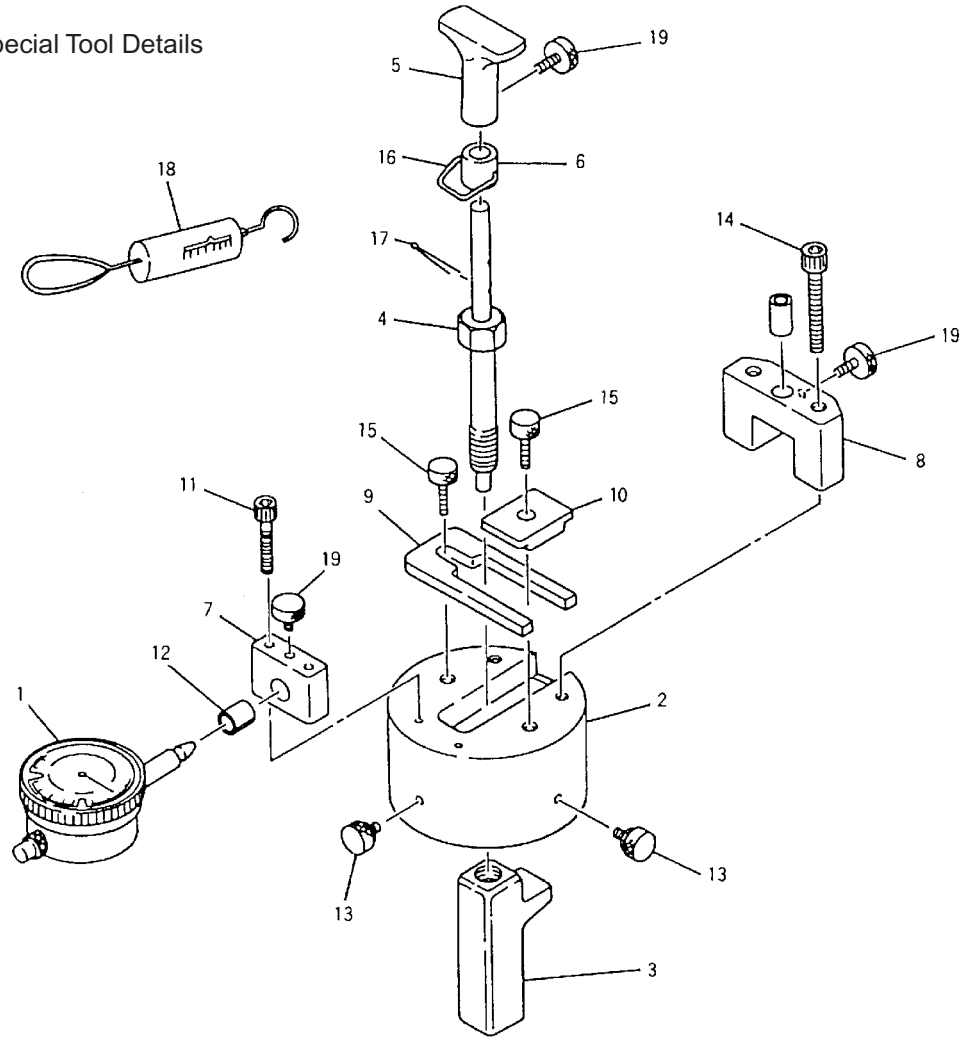

Key No.	Part name	Key No.	Part name
Assembly	Tool assembly	10	Stopper
1	Gauge (dial gauge)	11	Bolt
2	Guide	12	Sleeve
3	Stopper	13	Bolt
4	Bar	14	Bolt
5	Puller	15	Bolt
6	Sleeve	16	Hook
7	Plate	17	Snap ring (cotter pin)
8	Plate	18	Bar (spring)
9	Guide	19	Bolt

Replacement

JP30002140704001

1. Removal

- (1) Remove the boost pipe and U-turn pipe.
- (2) Disconnect all pipes connected to the turbocharger.

⚠ CAUTION

- **Loosen union bolt of the coolant pipe, drain coolant and remove the pipe. Disconnect the lower pipe similarly and remove the oil pipe.**
- **After removing pipes, be sure to seal oil holes, water holes and cylinder block holes to prevent entry of dirt.**

- (3) Remove the bolts fixing the exhaust pipe and the turbocharger and remove the turbocharger.

⚠ CAUTION

- **After removal, seal holes both at the exhaust manifold and the exhaust pipe to prevent entry of foreign matter.**
- **If a stud bolt is sticking, remove and replace the stud bolt using a commercially available stud remover.**

2. Installation

- (1) Install the turbocharger in the reverse order of disassembly. When the turbocharger is installed on the engine or after installation, observe the following precautions for work. Pay special attention to entry of foreign matter inside the turbocharger.

Tightening torque :

56 N · m {570 kgf · cm, 41 lbf · ft}

(Turbocharger to exhaust manifold)

- (2) Lubrication and cooling system
 - a. Before installation on the engine, pour new engine oil from the oil inlet and turn the turbocharger with hand to lubricate the journal bearing and the thrust bearing.
 - b. Clean the oil pipe, oil hose, coolant pipe and hose. Check for pipe deformation, hose crack or dirt or foreign matter in the pipe or hose.
 - c. Do not use sealant at the installation surface of the oil pipe and the coolant pipe or joint between the coolant hose and the coolant pipe to prevent failures such as damage due to clogging or loosening of tightened areas.
 - d. Be sure to use new soft washers, O-rings and gaskets.
 - e. Be sure to install the oil pipe, oil hose, coolant pipe and coolant hose correctly to prevent leak of oil or water from connections.

- (3) Air intake system
 - a. Make sure that there is no dirt or foreign matter in the air intake system.
 - b. Do not use sealant at the inlet/outlet of air to prevent failures such as damage due to clogging or loosening of tightened areas.
 - c. Be sure to install the air feed pipe and the air hose correctly to prevent air leak from connections.
- (4) Exhaust system
 - a. Make sure that there is no dirt or foreign matter in the exhaust piping system.
 - b. Since heat resistant steel is used for bolts and nuts, do not mix them with normal bolts for installation.

15 FAILURE DIAGNOSIS FOR EACH ENGINE STATUS

FAILURE DIAGNOSIS FOR EACH ENGINE STATUS

.....	15-2
Engine mechanical	15-2
Alternator	15-4
Starter	15-5
Turbocharger.....	15-6

FAILURE DIAGNOSIS FOR EACH ENGINE STATUS

Engine mechanical

JP30002150601001

Status	Cause	Action
Engine overheat (coolant)	Insufficient coolant	Replenish coolant
	Faulty thermostat	Replace thermostat
	Water leak from cooling system	Correction
	Faulty coolant pump	Repair or replace
	Faulty head gasket	Replace head gasket
Engine overheat (radiator)	Clogging of radiator	Cleaning of radiator
	Corrosion of cooling system	Clean and repair cooling system
	Clogging of radiator core front part	Clean radiator
	Faulty radiator cap	Replace radiator cap
Engine overheat (compression pressure)	Non-synchronous injection timing	Adjust injection timing.
	Faulty fuel injection pressure	Adjust injection pressure
	Faulty fuel	Replace with correct fuel
	Faulty injector	Replace injector
Engine overheat (lubrication unit)	Deterioration of engine oil	Replace engine oil
	Faulty oil pump	Replace oil pump
	Insufficient engine oil	Replenish engine oil
Large engine oil consumption (piston, cylinder liner and piston ring)	Wear of piston ring and cylinder liner	Replace piston ring and cylinder liner
	Damage to piston ring	Replace piston ring and cylinder liner
	Faulty fixing of piston ring	Replace piston ring and cylinder liner
	Faulty assembly of piston ring	Replace piston ring and cylinder liner
	Faulty engine oil	Replace engine oil
	Faulty piston ring joint	Reassemble piston ring
Large engine oil consumption (valve and valve guide)	Wear of valve stem	Replace valve and valve guide
	Wear of valve guide	Replace valve guide
	Faulty assembly of valve stem seal	Replace stem seal
	Excessive oil lubrication to rocker arm	Inspection of clearance between rocker arm and rocker arm shaft
Large engine oil consumption (others)	Faulty oil level gauge	Replace with correct level gauge
	Excessive filling of engine oil	Fill with appropriate amount of oil.
	Leak of engine oil	Repair or replace the part of oil leak.
Piston seizure (in operation)	Sudden stop of engine	Perform warm-up before stop of engine
Piston seizure (lubrication unit)	Insufficient engine oil	Replenish engine oil
	Deterioration of engine oil	Replace engine oil
	Incorrect engine oil	Replace with correct engine oil.
	Low oil pressure	Inspection of lubrication unit
	Faulty oil pump	Replace oil pump
Piston seizure	Abnormal combustion	Refer to overheat section.
Piston seizure	Cooling unit	Refer to overheat section.

Status	Cause	Action
Insufficient engine power (air cleaner)	Clogging of air cleaner element	Clean or replace air cleaner element
Insufficient engine power	Overheat	Refer to overheat section.
Insufficient engine power (fuel unit)	Faulty injection of injector	Replace injector
	Faulty injector due to deposit of carbon	Replace injector
	Entry of air into fuel system	Air bleeding of fuel system
	Faulty fuel filter	Replace element
	Faulty fuel	Replace with correct fuel
Insufficient engine power	Abnormal compression pressure	Refer to overheat section.
Insufficient engine power	Piston, cylinder liner and piston ring	Refer to overheat section.
Faulty engine start (electric unit)	Faulty battery	Check battery
	Faulty wiring of starter	Replace starter wiring
	Loose battery cable	Tighten battery terminal connection or replace cable
	Faulty operation of starter	Replace starter assembly
	Faulty start assist unit	Replace start assist unit
Faulty engine start (air cleaner)	Clogging of air cleaner element	Clean or replace air cleaner element
Faulty engine start (fuel unit)	Insufficient fuel	Replenish fuel and bleed air from fuel system
	Clogging of fuel system	Clean fuel system.
	Air intake from connection of fuel system	Tighten connections
	Clogging of fuel filter	Replace fuel filter
	Loose connection of injection pipe	Tighten connecting nut of injection pump
Faulty engine start (injector)	Injector seizure	Replace injector
Faulty engine start (lubrication unit)	Excessive viscosity of engine oil	Replace with engine oil with correct viscosity
Faulty engine start (others)	Piston seizure	Replace piston, piston ring and cylinder liner
	Bearing seizure	Replace bearing and crankshaft
	Low compression pressure	Overhaul engine
	Damage to ring gear	Replace ring gear and replace starter pinion gear.
Faulty idling (injector)	Faulty injection pressure	Adjust injection pressure.
	Faulty injection status	Adjust or replace injector.
Faulty idling (nozzle)	Faulty injection pressure	Adjust injection pressure.
	Faulty spray status	Adjust or replace nozzle
	Carbon deposit at nozzle end	Remove carbon
	Seizure of needle valve	Replace nozzle

Status	Cause	Action
Faulty idling (engine)	Faulty valve clearance	Adjustment of valve clearance
	Faulty contact of valve seat	Adjust or replace valve and valve seat.
	Low coolant temperature	Perform warm-up.
	Large variation of compression pressure between cylinders	Overhaul engine
Gas leak (head gasket)	Reuse	Replace gasket.
	Damage	Replace gasket.
	Replace gasket.	Replace gasket.
Gas leak (head bolt)	Loose head bolt	Tighten bolt.
	Incorrect tightening sequence or incorrect tightening torque	Tighten bolt to correct torque according to the correct tightening sequence.
	Extension of head bolt	Replace bolt.
Gas leak (cylinder block)	Crack	Replace cylinder block.
	Distortion of cylinder block upper surface	Repair or replace cylinder block.
	Depression of cylinder liner insertion (insufficient protrusion of cylinder liner)	Replace cylinder liner or block.
Gas leak (cylinder head)	Crack of cylinder head	Replace cylinder head.
	Distortion of cylinder head lower surface	Repair or replace cylinder head.
Gas leak (cylinder liner)	Crack of cylinder liner	Replace cylinder liner.
	Corrosion of cylinder liner	Replace cylinder liner.
	Insufficient protrusion of cylinder liner	Replace cylinder liner or block.
Gas leak (others)	Incorrect injection timing	Adjust injection timing.

Alternator

JP30002150601002

Status	Cause	Action
Lamp is ON. →Charge current does not run (alternator).	Faulty regulator (open PTr)	Replace regulator.
	Faulty stator coil (disconnection, rare shorting)	Replace stator coil.
	Fault feed coil (disconnection, rare shorting)	Replace feed coil.
	Faulty diode (open, shorting)	Replace rectifier.
	Disconnection or poor contact of lead wire (plate, support, etc.)	Repair or replace lead wire.
Lamp is ON. →Charge current does not run (wiring).	Disconnection of wire (fuse)	Replace wire (fuse).
Lamp is ON. →Voltmeter indicates 29V or more (alternator).	Faulty regulator (shorting of PTr)	Replace regulator.
	Faulty tightening of voltage detection circuit (e.g. support)	Repair, replace voltage detection circuit or replace regulator.

Status	Cause	Action
Lamp is ON. →Charge current is correctly running (alternator).	Faulty regulator (open Tr)	Replace regulator.
Lamp is OFF. →Charge current is always limited. →Battery goes flat (alternator).	Faulty stator coil (disconnection of 1 phase, rare shorting)	Replace stator coil.
	Faulty diode (open, shorting)	Replace rectifier.
	Disconnection or poor contact of lead wire (plate, support, etc.)	Repair or replace lead wire.
Lamp is OFF. →Charge current is always limited. →Battery goes flat (operation load).	Operation load is large (Load balance is poor).	Reduce load
Lamp is OFF. →Charge current is always large. →Battery fluid runs short in a short period of time (alternator).	Faulty regulator (shorting of PTr)	Replace regulator.
	Faulty tightening of voltage detection circuit (e.g. support)	Repair or replace voltage detection circuit.
Lamp is OFF. →Charge current is always large. →Battery fluid runs short in a short period of time (battery).	Battery is close to the service life.	Replace battery.
Others →Abnormal noise (alternator)	Faulty stator coil (rare shorting, grounding)	Replace stator coil.
	Contact of inner surface (faulty bearing, wear of bracket)	Repair or replace bearing.
Others →Abnormal noise (V belt)	Faulty tension of V belt (belt slip)	Correction

Starter

JP30002150601003

Status	Cause	Action
Starter does not turn. Turning is low.	Faulty connection of starter key	Repair connecting area.
	Flat battery	Charge or replace.
	Disconnection, loosening or corrosion of battery terminal	After cleaning, tighten.
	Grounding wire is disconnected.	Be sure to connect it.
	Use of incorrect engine oil	Replace with correct oil.
	Faulty contact of start magnet switch assembly.	Replace start magnet switch assembly
	Faulty contact or failure of starter relay	Replace starter relay.
	Wear of starter brush	Replace brush
	Seizure of commutator	Repair commutator.
	Wear of commutator	Undercut
	Shorting of armature	Replace armature assembly
	Insufficient tension of brush spring	Replace brush spring.
	Faulty operation of clutch	Clean or replace.

Turbocharger

JP30002150601004

Status	Cause	Action
Exhaust smoke is black (insufficient intake air).	Clogging of air cleaner element	Clean or replace air cleaner element.
	Air intake inlet is closed.	Recover normal status.
	Leak from connection of air intake system	Check and repair.
	Revolution of blower impeller and turbine shaft is heavy	Disassembly and repair.
Exhaust smoke is black (Turbocharger is not operating).	Oil impurities are deposited at the sealing part of the turbine and revolution of the turbine shaft is heavy.	Replace engine oil and disassemble the turbocharger for cleaning.
	Seizure of bearing	Replace turbocharger.
	Seizure of bearing (insufficient lubrication or clogging of oil pipe)	Check the oil system of the engine and repair faulty areas. Also, replace engine oil.
	Seizure of bearing (Oil temperature is too high.)	Check the oil system of the engine and repair faulty areas. Also, replace engine oil.
	Seizure of bearing (Balance of revolving body is poor.)	Replace or clean revolving part.
	Seizure of bearing (insufficient warm-up or sudden stop from loaded operation: Unloaded operation)	Observe the precautions strictly in the operation manual.
	Contact of or damage to turbine shaft and blower impeller (excessive operation)	Check and repair engine parts.
	Contact of or damage to turbine shaft and blower impeller (excessive increase of exhaust gas temperature)	Check and repair engine parts.
	Contact of or damage to turbine shaft and blower impeller (entry of foreign matter)	Disassemble the engine to remove foreign matter completely. Check and repair the air cleaner and engine parts.
	Contact of or damage to turbine shaft and blower impeller (wear of bearing)	Replace turbocharger.
	Contact of or damage to turbine shaft and blower impeller (faulty assembly)	Reassemble or replace.
Exhaust smoke is black (due to exhaust gas resistance).	Exhaust gas is leaking before the turbocharger. Revolution is not increased.	Check and repair mounting area.
	Since pipe of the exhaust system is deformed or clogged, revolution of the turbocharger is not increased.	Recover normal status.

Status	Cause	Action
Exhaust smoke is white.	Engine oil runs out to the blower or the turbine due to clogging or deformation of the oil return pipe.	Repair or replace pipe.
	Negative pressure at the back of the blower impeller is increased and engine oil runs out to the blower.	Check and replace the pipe. Replace or clean the air cleaner element.
	Seal ring is excessively worn or damaged due to excessive wear of the bearing.	Disassemble and repair turbocharger.
Oil is quickly reduced.	Seal ring is excessively worn or damaged due to excessive wear of the bearing.	Disassemble and repair turbocharger.
	Engine oil enters into exhaust gas before the turbocharger.	Check and service engine parts.
Low engine output	Gas leak from exhaust system parts	Check and repair faulty areas.
	Air leak from blower outlet	Check and repair faulty areas.
	Clogging of air cleaner element	Clean or replace air cleaner element
	Contamination of or damage to turbocharger	Replace turbocharger.
Acceleration (follow-up of turbocharger) is poor (slow).	Carbon deposit at the turbine (disc sealing area) makes revolution of the turbine heavy.	Replace engine oil and clean turbocharger.
	Air and gas leak from intake/exhaust system parts	Check and repair faulty areas.
	Combustion is faulty.	Check the engine fuel system and recover correct combustion status.
Abnormal noise	If the gas passage is extremely narrowed due to clogging at the turbine case nozzle or if acceleration is performed, reverse flow (usually called surging) occurs due to clogging of blower discharge air.	Replace turbocharger.
	Revolving part is in contact.	Replace turbocharger.
	Air and gas leak from intake/exhaust system parts	Check and repair faulty areas.
Vibration	Loosening between turbocharger and intake/exhaust pipe and between oil pipe and mounting area	Check the turbocharger mounting status and repair faulty areas.
	Failure of metal, contact between revolving part and peripheral parts, or damage to the blower impeller of the turbine rotor due to entry of foreign matter is found.	Replace turbocharger. Remove foreign matter completely, if any.
	Balance of revolving body is poor.	Replace revolving body.

16 ENGINE DIAGNOSIS CODE

Engine ECU	16-2		
Precautions	16-2		
System block diagram.....	16-3		
Inspection	16-4		
Connection method of Hino-DX	16-5		
Table of failure code	16-7		
Signal check harness.....	16-11		
Computer pin arrangement.....	16-13		
Check the ECU power supply voltage.....	16-14		
Check the ground.....	16-14		
Engine speed main sensor circuit malfunction (DTC code P0335/diagnosis monitor code 13)	16-15		
Engine speed sub sensor circuit malfunction (DTC code P0340/diagnosis monitor code 12)	16-16		
Engine speed main and sub sensor circuit malfunction (DTC code P0335/diagnosis monitor code 13) ...	16-17		
Coolant temperature sensor malfunction (DTC code P0117, P0118/diagnosis monitor code 11).....	16-18		
Engine overheat (DTC code P0217/diagnosis monitor code 6).....	16-19		
Engine overrun (DTC code P0219/diagnosis monitor code 7).....	16-19		
Fuel temperature sensor malfunction (DTC code P0182, P0183/diagnosis monitor code 14).....	16-20		
Boost pressure sensor malfunction (DTC code P0108, P0237/diagnosis monitor code 37)	16-21		
Turbocharger over boost (DTC code P0234/diagnosis monitor code 39).....	16-23		
Excessive common rail pressure (DTC code P0088/diagnosis monitor code 68, 69).....	16-23		
Excessive common rail pressure, supply pump excess forced feed (DTC code P0088/diagnosis monitor code 76).....	16-24		
Common rail pressure sensor malfunction (DTC code P0191/diagnosis monitor code 67)	16-25		
Common rail pressure sensor malfunction (DTC code P0192, P0193/diagnosis monitor code 67).....	16-26		
Accelerator sensor 1 malfunction (DTC code P2121/diagnosis monitor code 22).....	16-28		
Accelerator sensor 1 malfunction (DTC code P2122, P2123/diagnosis monitor code 22)	16-30		
Accelerator sensor 2 malfunction (DTC code P2126/diagnosis monitor code 22).....	16-31		
Accelerator sensor 2 malfunction (DTC code P2127, P2128/diagnosis monitor code 22)	16-33		
Accelerator sensor 1 and 2 malfunction (DTC code P2120/diagnosis monitor code 22)	16-34		
Atmospheric pressure sensor malfunction (DTC code P2228, P2229/diagnosis monitor code 15).....	16-34		
		Injector common 1 short to GND (DTC code P1211/diagnosis monitor code 57), Injector common 2 short to GND (DTC code P1214/diagnosis monitor code 58)	16-35
		Injector common 1 short to BATT (DTC code P1212/diagnosis monitor code 57), Injector common 2 short to BATT (DTC code P1215/diagnosis monitor code 58)	16-37
		Injector circuit malfunction (DTC code P0201 to P0206/diagnosis monitor code 51 to 56).....	16-39
		Cylinder contribution/balance fault (DTC codes P0263, P0266, P0269, P0272, P0275, P0278/diagnosis monitor code 61 to 66).....	16-42
		SCV malfunction (DTC code P0628, P0629/diagnosis monitor code 74).....	16-44
		Supply pump SCV sticking (DTC code P2635/diagnosis monitor code 75), Supply pump malfunction (DTC code P2635/diagnosis code 77), Supply pump abnormal pressure record (DTC code P2635/diagnosis monitor code 79).....	16-46
		EGR solenoid 1 malfunction (DTC code P0489, P0490/diagnosis monitor code 81)	16-47
		EGR solenoid 2 malfunction (DTC code P1402, P1403/diagnosis monitor code 82)	16-48
		EGR valve 1 stick (DTC code P0404/diagnosis monitor code 88).....	16-49
		EGR valve 2 stick (DTC code P1401/diagnosis monitor code 89).....	16-49
		EGR lift sensor 1 malfunction (DTC code P0405, P0406/diagnosis monitor code 86)	16-50
		EGR lift sensor 2 malfunction (DTC code P0407, P0408/diagnosis monitor code 87)	16-52
		Preheat circuit malfunction (DTC code P0540/diagnosis monitor code 25).....	16-54
		Injector correction data conformity error (DTC code P1601/diagnosis monitor code 2)	16-55
		ECU internal error (DTC code P0605, P0606, P0607/diagnosis monitor code 3).....	16-55
		ECU charge circuit malfunction (DTC code P0200, P0611/diagnosis monitor code 59)	16-56
		Main relay malfunction (DTC code P0686/diagnosis monitor code 5).....	16-56
		Idle volume malfunction (DTC code P1142, P1143/diagnosis monitor code 44).....	16-58
		Idle switch malfunction (DTC code P0510/diagnosis monitor code 42).....	16-60
		Starter signal malfunction (DTC code P0617/diagnosis monitor code 45).....	16-61

Engine ECU

Precautions

JP30002160102001

- ⚠ CAUTION**
- **Make sure that each connector is connected before inspection.**
 - **Do not place a tester rod on the connecting surface of the connector. Otherwise, terminals are damaged or short-circuited.**
 - **Delete the past failure memory after recording. Perform failure diagnosis again to check current failure.**
 - **After failure analysis, delete the past failure memory. If the past failure memory is not deleted, the failure indicator lamp remains ON.**
 - **All connector drawings are viewed from the connecting surface. Place the tester rod from the back.**

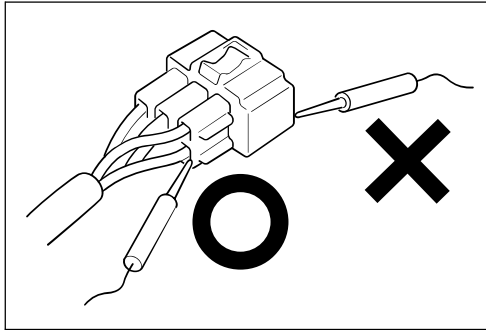

SAPH300021600001

Inspection

JP30002160703001

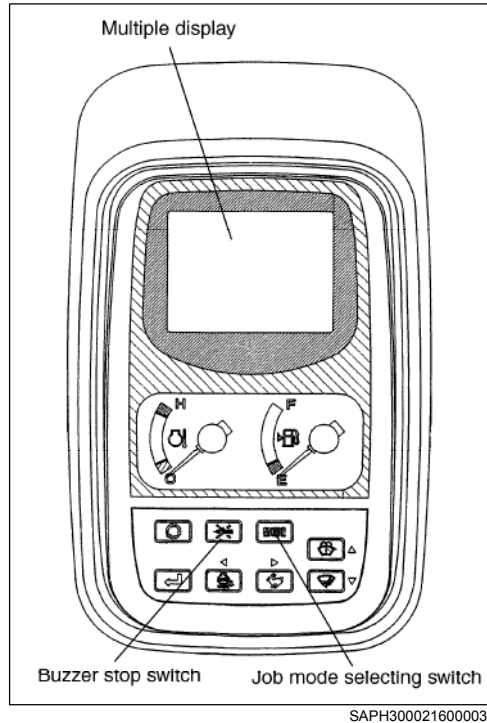

1. Pre-inspection

- (1) If the system has an error, the failure code(DTC code) is displayed on the multiple display of gauge cluster.

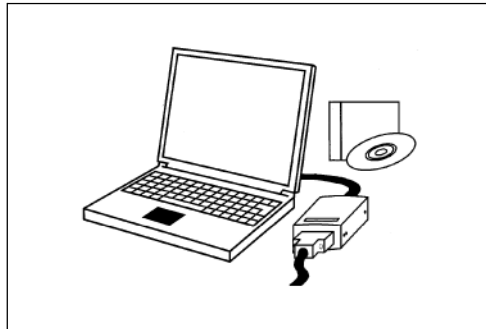

2. Deletion method of past failure

- (1) To delete past failures of the engine ECU, use HINO-DX on the PC. (Refer to "Hino field support system operation manual".)

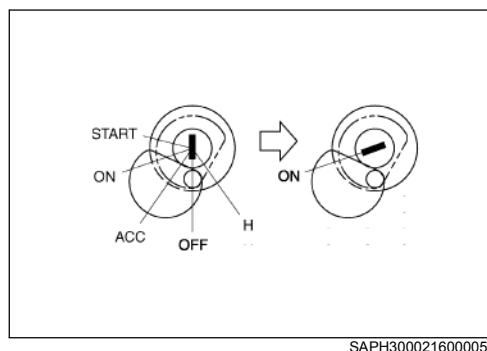

3. Deletion of cluster gauge past failure

- (1) Turn "ON" the starter switch.
- (2) When the buzzer stop switch is pressed consecutively 5 times in 10 seconds, the failure history mode is displayed.
- (3) Press work mode selecting switch and the buzzer stop switch at the same time for 10 seconds or more.
- (4) When the display shows "No error", deletion is completed.
- (5) Turn "OFF" the starter switch.

Connection method of Hino-DX

JP30002160301001

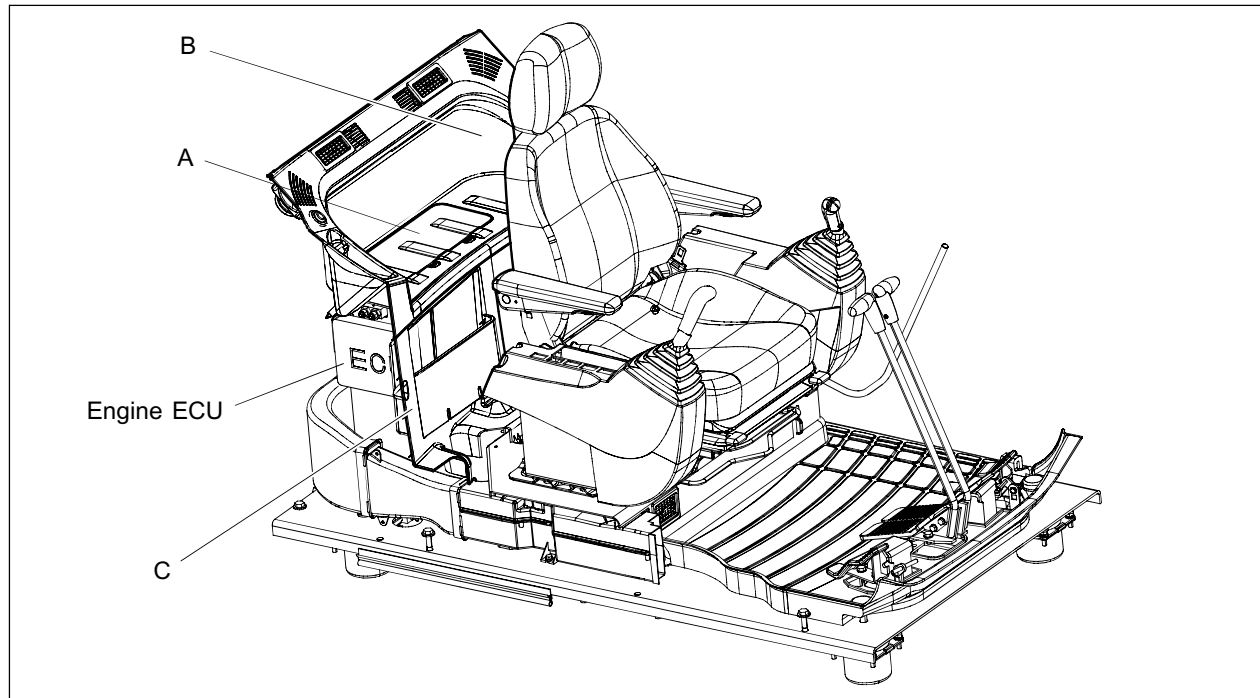

SAPH300021600006

1. Removal of cover at the rear of the driver's seat

- (1) Remove maintenance cover A. (Two tabs)
- (2) Remove the rear cover B mounting bolts M6 (4 places) which are found after removing maintenance cover A and remove the clips at the back of rear cover B.
- (3) Remove rear cover B.
- (4) Remove bolts M6 (2 places) at the lower part of rear cover C and clips (2 places) and remove cover C.

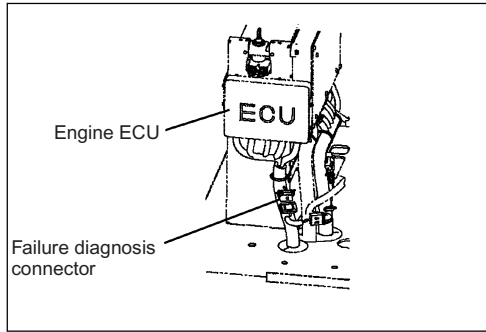

2. Connection of Hino-DX

- (1) Connect the system to the failure diagnosis connector through the interface box.

Special tool : 380100046 Hino-Bowie (Interface box)
380100047 Connecting cable
380100045 CD-ROM Hino-DX

- (2) Set the starter key to "ON" and start Hino-DX.

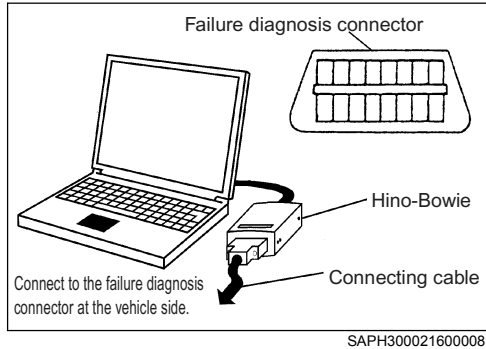

Table of failure code

JP30002160601001

- NOTICE**
- For the system status by indication of failure code(DTC code) in the table, refer to "1. Pre-inspection, Inspection, Engine ECU".
"Reference : Inspection, Engine ECU, Engine diagnosis code"

[a] Failure diagnosis and [b] Alarm display (alarm status)	DTC code	Diagnosis monitor code	Estimated failure cause
a. Engine does not start Engine stopped.	P0335	13	Engine speed main sensor circuit malfunction
b. Failure code(DTC code) indication.	P0606	3	CPU malfunction (Hard detection) (Detection of hardware)
	P0629	74	SCV out put short to BATT (+B short-circuit)
a. Low output	P0200	59	ECU charge circuit high input
b. Failure code(DTC code) indication.	P0611	59	ECU charge circuit malfunction
a. Low output (limp form)	P2120	22	Accelerator sensor 1 and 2 malfunction
b. Failure code(DTC code) indication.			
a. Low output	P0217	6	Engine overheat
a. Difficult to start engine.	P0540	25	Preheat circuit malfunction (Open/ground short-circuit)
	P0540	25	Preheat circuit malfunction (+B short-circuit)
a. Low output	P0234	39	Turbocharger over boost

[a] Failure diagnosis and [b] Alarm display (alarm status)	DTC code	Diagnosis monitor code	Estimated failure cause
a. Low output	P0088	68	Excessive common rail pressure (1st step)
b. Failure code(DTC code) indication.	P0088	69	Excessive common rail pressure (2nd step)
	P0088	76	Excessive common rail pressure, supply pump excess forced feed
	P0108	37	Boost pressure sensor circuit high input
	P0117	11	Coolant temperature sensor circuit low input
	P0118	11	Coolant temperature sensor circuit high input
	P0191	67	Common rail pressure sensor malfunction
	P0192	67	Common rail pressure sensor circuit low input
	P0193	67	Common rail pressure sensor circuit high input
	P0201	51	Injector circuit malfunction -cylinder 1
	P0202	52	Injector circuit malfunction -cylinder 2
	P0203	53	Injector circuit malfunction -cylinder 3
	P0204	54	Injector circuit malfunction -cylinder 4
	P0205	55	Injector circuit malfunction -cylinder 5
	P0206	56	Injector circuit malfunction -cylinder 6
	P0237	37	Boost pressure sensor circuit low input
	P0404	88	EGR valve 1 stick
	P0405	86	EGR lift sensor 1 circuit low input
	P0406	86	EGR lift sensor 1 circuit high input
	P0407	87	EGR lift sensor 2 circuit low input
	P0408	87	EGR lift sensor 2 circuit high input
	P0489	81	EGR solenoid 1 malfunction (Open/ground short-circuit)

[a] Failure diagnosis and [b] Alarm display (alarm status)	DTC code	Diagnosis monitor code	Estimated failure cause
a. Low output	P0490	81	EGR solenoid 1 malfunction (VB short-circuit)
b. Failure code(DTC code) indication.	P0605	3	Flash ROM error
	P0607	3	Monitoring IC malfunction in CPU
	P0628	75	SCV malfunction (Full discharge mode)
	P1211	57	Injector common 1 short to GND Failure of ground short-circuit and common 1
	P1212	57	Injector common 1 short to BATT Failure of +B short-circuit and common 1
	P1212	57	Injector common 1 short to BATT Failure of open and common 1
	P1214	58	Injector common 2 short to GND Failure of ground short-circuit and common 2
	P1215	58	Injector common 2 short to BATT Failure of +B short-circuit and common 2
	P1215	58	Injector common 2 short to BATT Failure of open and common 2
	P1401	89	EGR valve 2 stick
	P1402	82	EGR solenoid 2 malfunction (Open/ground short-circuit)
	P1403	82	EGR solenoid 2 malfunction (VB short-circuit)
	P1601	2	Injector correction data conformity error
	P2228	15	Atmospheric pressure sensor
	P2229	15	Atmospheric pressure sensor circuit high input
P2635	75	Supply pump SCV sticking	
P2635	77	Supply pump malfunction	

[a] Failure diagnosis and [b] Alarm display (alarm status)	DTC code	Diagnosis monitor code	Estimated failure cause
a. Other problems	P0182	14	Fuel temperature sensor circuit low input
b. Failure code(DTC code) indication.	P0183	14	Fuel temperature sensor circuit high input
	P0340	12	Engine speed sub sensor circuit malfunction
	P0686	5	Main relay malfunction
	P2122	22	Accelerator sensor circuit 1 low voltage
	P2123	22	Accelerator sensor circuit 1 high voltage
	P2127	22	Accelerator sensor circuit 2 low voltage
	P2128	22	Accelerator sensor circuit 2 high voltage
a. Other problems	P0219	7	Engine overrun
b. No indication	P0263	61	Cylinder 1 contribution/balance fault
	P0266	62	Cylinder 2 contribution/balance fault
	P0269	63	Cylinder 3 contribution/balance fault
	P0272	64	Cylinder 4 contribution/balance fault
	P0275	65	Cylinder 5 contribution/balance fault
	P0278	66	Cylinder 6 contribution/balance fault
	P0617	45	Starter signal malfunction
	P2635	79	Supply pump abnormal pressure record
	U1001	9	Interruption of CAN communication (vehicle)

Signal check harness

JP30002160301002

1. Signal check harness

- CAUTION** • When measuring terminal of the engine ECU, connect the signal check harness to prevent damage to the connector. Place the tester rod on the contact box of the signal check harness for measurement.

- NOTICE** • Terminal numbers in the text and the illustrations correspond as shown below in the "Computer pin arrangement".

ECU terminal name

ACC P1	ACC P2	NEU /SW	BK2 /SW	SCBA /SW	EXB CHK /SW	IC /S	FUEL OUT /SW	EXB -L
PI M 1	AC ASC	KEY /SW	EXB /SW	GRS /SW	GRR /SW	RETB /SW	ST /SW	RHT
	VIMC	KEY /SW	ES RBL	ASC /SW	BK1 /SW	ST /SW	ESC /NR /SW	PCV 1
THW	ASR OUT /SW	DG /SW	ID /SW	RETA DER	ABS	GRM /SW	ES /SW	PCV 2

ECU terminal number

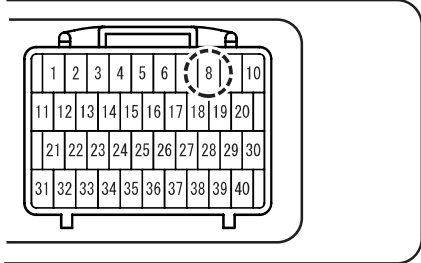

Signal check harness (contact box)

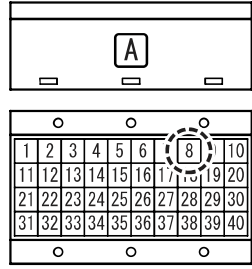

[Example] For A8 terminal

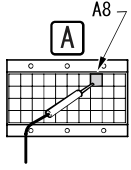

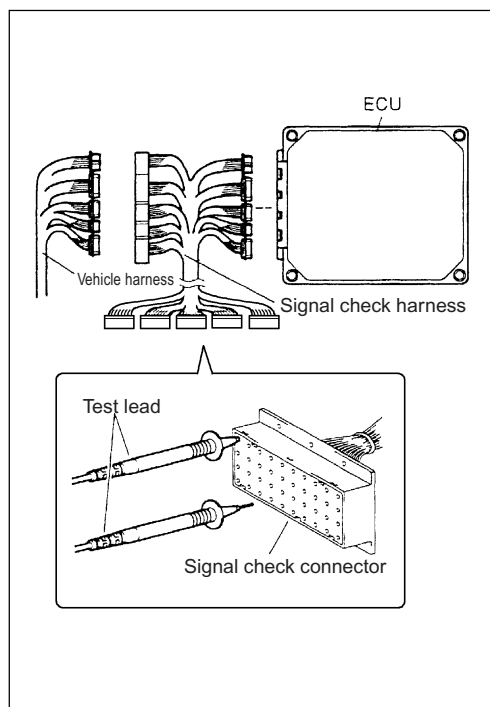

SAPH300021600010

2. Connection of signal check harness

- (1) Set the starter key to "LOCK" and disconnect the connector from the engine ECU.
- (2) Connect the signal check harness to the the engine ECU and the vehicle harness.

Special tool : Signal check harness (380100048)

Computer pin arrangement

JP30002160201001

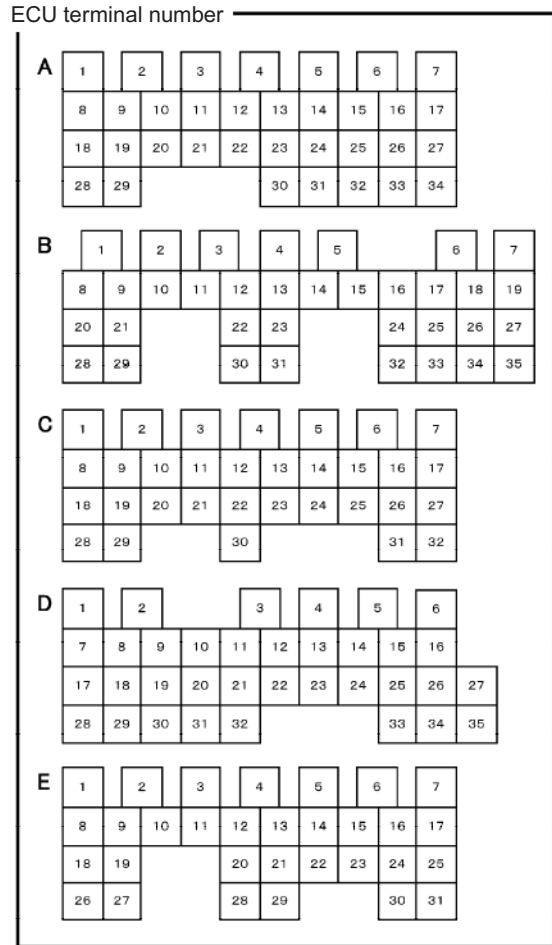
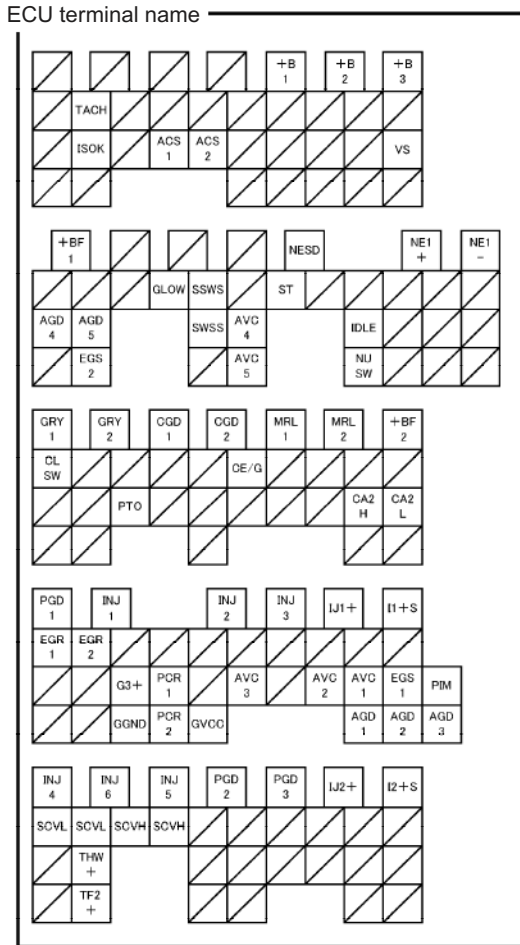

Signal check harness (contact box)

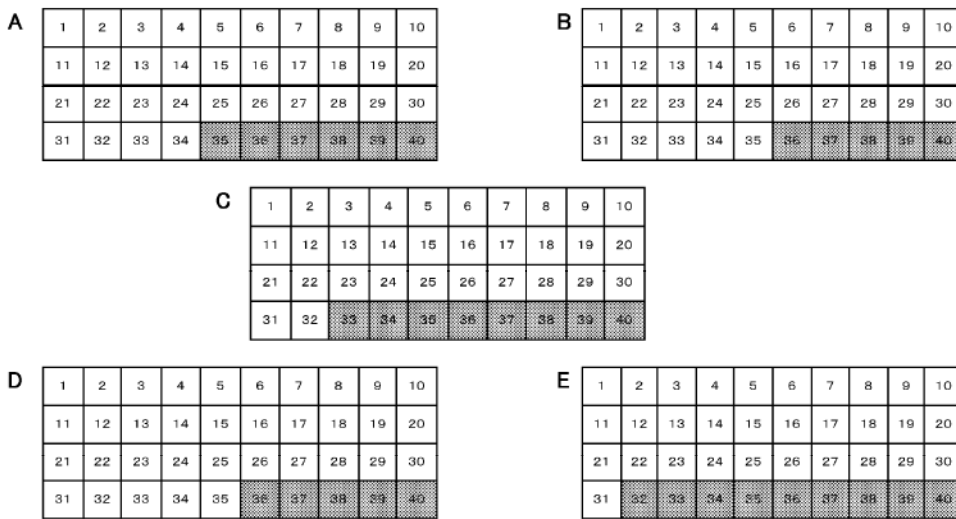

Check the ECU power supply voltage

JP30002160601002

1 Measurement of voltage between terminals

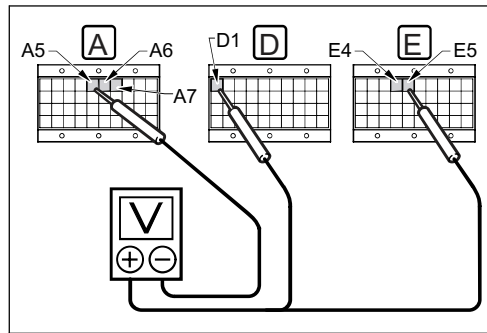

1. Set the starter key to "LOCK" and connect the signal check harness.
2. Turn the starter key "ON" and measure voltage between terminals A5, A6, A7 and terminals D1, E4, E5.

Standard value : 20 V or more

NG

- 0 V : Blown fuse, harness failure, ground failure, etc.
- 20 V or less : Battery deterioration, ground failure, etc.

OK

Normal

Check the ground

JP30002160601003

1 Measurement of resistance between terminals

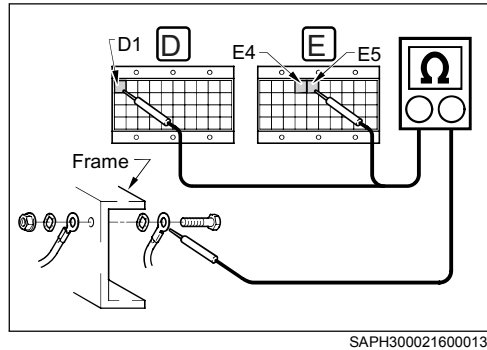

1. Set the starter key to "LOCK" and connect the signal check harness.
2. Disconnect the ECU side connector of the signal check harness and measure the resistance between terminals D1, E4, E5 and the terminal (-) of the battery.

Standard value : 1 Ω or less

NG

- Disconnection of ground harness, contact failure, etc.

OK

Normal

Engine speed main sensor circuit malfunction (DTC code P0335/diagnosis monitor code 13)

JP30002160601004

1 Measurement of resistance between terminals

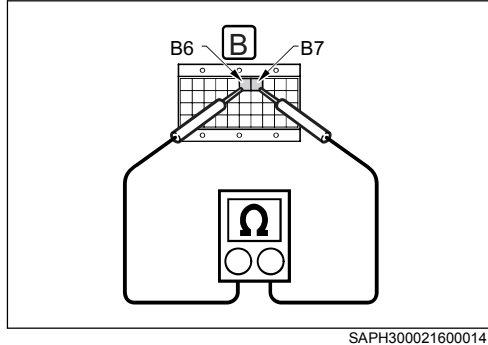

1. Set the starter key to "LOCK" and connect the signal check harness.
2. Disconnect the ECU side connector of the signal check harness and measure the resistance between terminal B6 and terminal B7.

Standard value : Approx. $125.5 \pm 17 \Omega$ (20 °C {68 °F})

NG

[3] Go to measurement of resistance between sensor terminals.

OK

2 Check of diagnosis code

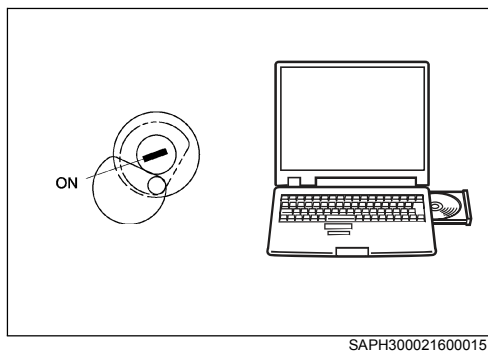

1. Connect the ECU side connector of the signal check harness. After deleting the past failure, output the diagnosis code again.

Standard : Normal

NG

Contact failure of ECU connector, ECU failure, short-circuit of harness

OK

Normal

3 Measurement of resistance between terminals

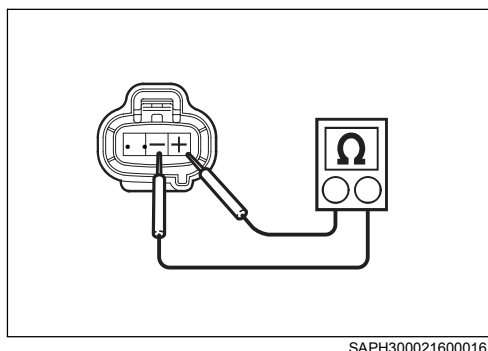

1. Disconnect the connector of the main engine speed sensor and measure the resistance between No. 1 and No. 2 terminals at the sensor.

Standard value : Approx. $125.5 \pm 17 \Omega$ (20 °C {68 °F})

NG

Failure of main engine speed sensor

OK

Harness disconnection or connector failure

Engine speed sub sensor circuit malfunction (DTC code P0340/diagnosis monitor code 12)

JP30002160601005

1 Measurement of voltage between sensor terminals

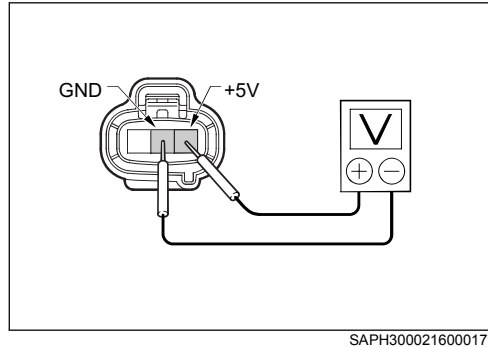

1. Set the starter key to "LOCK" and connect the signal check harness.
2. Disconnect the connector of the sub-speed sensor.
3. Set the starter key to "ON" and measure voltage between the +5V terminal and the GND terminal of the sub-speed sensor connector (at machine harness side).

Standard value : 5.0 ±0.5 V

NG

[2] Go to measurement of voltage between terminals.

OK

[3] Go to measurement of voltage between terminals.

2 Measurement of voltage between terminals

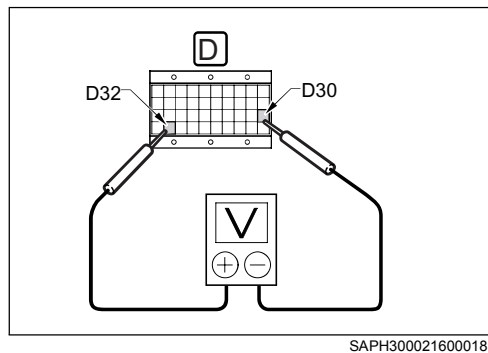

1. Measure voltage between terminal D32 and terminal D30 of the signal check harness.

Standard value : 5.0 ±0.5V

NG

Engine ECU failure, connector failure

OK

Harness failure

3 Measurement of voltage between terminals

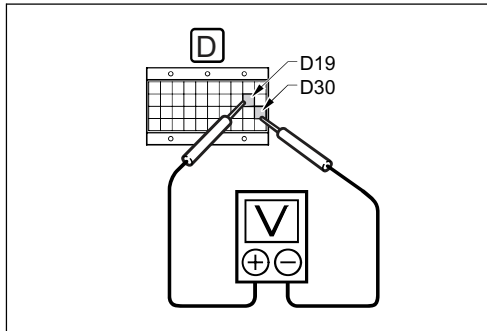

1. Set the starter key to "OFF" and connect the connector of the sub-speed sensor.
2. Start the engine and keep idling status.
3. Measure voltage between terminal D19 and terminal D30 of the signal check harness.
4. After measurement, stop the engine.

Standard : Pulse waveform of 0 ↔ 5 V

NG

[4] Go to measurement of resistance between terminals.

OK

Engine ECU failure, ECU connector failure

4 Measurement of resistance between terminals

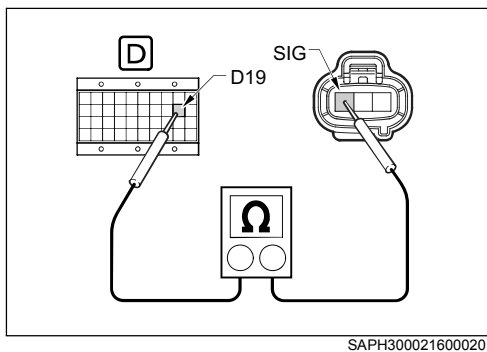

1. Leave the connector of the sub-speed sensor connected.
2. Measure resistance between the No. 1 terminal at the vehicle harness of the sub-speed sensor connector and terminal D19 of the signal check harness.

CAUTION • The connector of the sub-speed sensor in the figure is viewed from the fitting surface.

Standard value : 2 Ω or less

NG

Harness failure

OK

Failure of sub-speed sensor

Engine speed main and sub sensor circuit malfunction (DTC code P0335/diagnosis monitor code 13)

JP30002160601006

1. Inspection item

- (1) Take actions of (DTC code P0335/diagnosis monitor code 13) and (DTC code P0340/diagnosis monitor code 12).

"Reference : Engine speed main sensor circuit malfunction (DTC code P0335/diagnosis monitor code 13), Engine ECU, Engine diagnosis code"

"Reference : Engine speed sub sensor circuit malfunction (DTC code P0340/diagnosis monitor code 12), Engine ECU, Engine diagnosis code"

Coolant temperature sensor malfunction (DTC code P0117, P0118/diagnosis monitor code 11)

JP30002160601007

DTC	P0117	Coolant temperature sensor circuit low input
DTC	P0118	Coolant temperature sensor circuit high input

1 Measurement of resistance between terminals

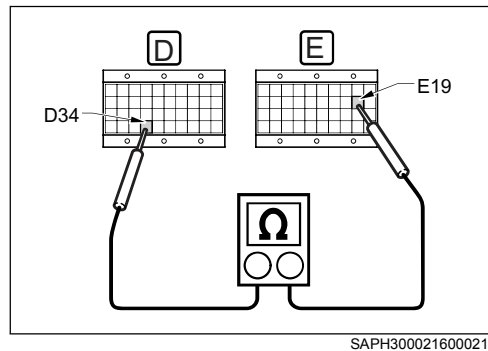

1. Set the starter key to "LOCK" and connect the signal check harness.
2. Disconnect the ECU side connector of the signal check harness and measure the resistance between terminal B19 and terminal D34.

Standard value (Measure either one point of the following.)

- : 2.45 k Ω (Coolant temperature at 20 °C{68 °F})
- : 1.15 k Ω (Coolant temperature at 40 °C{104 °F})
- : 584 Ω (Coolant temperature at 60 °C{140 °F})
- : 318 Ω (Coolant temperature at 80 °C{176 °F})

NG

[2] Go to measurement of resistance between sensor terminals.

OK

Engine ECU failure, ECU connector failure, harness short-circuit

2 Measurement of resistance between terminals

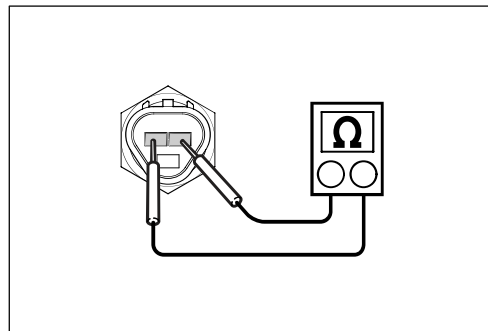

1. Disconnect the connector of the coolant temperature sensor and measure the resistance between No. 1 and No. 2 terminals at the sensor.

Standard value (Measure either one point of the following.)

- : 2.45 k Ω (Coolant temperature at 20 °C{68 °F})
- : 1.15 k Ω (Coolant temperature at 40 °C{104 °F})
- : 584 Ω (Coolant temperature at 60 °C{140 °F})
- : 318 Ω (Coolant temperature at 80 °C{176 °F})

NG

Failure of coolant temperature sensor

OK

Harness disconnection, connector failure

Engine overheat (DTC code P0217/diagnosis monitor code 6)

JP30002160601008

1 Measurement of resistance between terminals

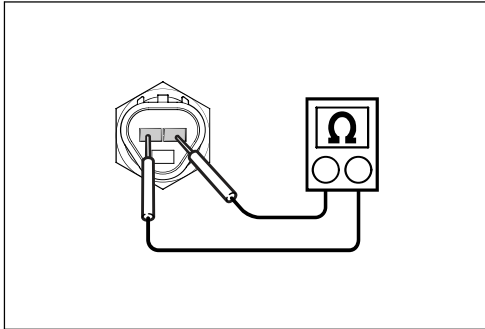

1. Set the starter key to "LOCK", disconnect the connector of the coolant temperature sensor and measure the resistance between No. 1 and No. 2 terminals at the sensor.

Standard value (Measure either one point of the following.)

- : 2.45k Ω (Coolant temperature at 20 °C{68 °F})
- : 1.15k Ω (Coolant temperature at 40 °C{104 °F})
- : 584 Ω (Coolant temperature at 60 °C{140 °F})
- : 318 Ω (Coolant temperature at 80 °C{176 °F})

NOTICE

- This code is displayed when the coolant temperature sensor is normal and the coolant temperature is 115 °C{221 °F} or more.
- While this failure code is detected, the maximum injection volume is restricted. When the coolant temperature is 80 °C{176 °F} or less, normal control is resumed.

NG

Failure of coolant temperature sensor

OK

Failure of engine cooling system

Engine overrun (DTC code P0219/diagnosis monitor code 7)

JP30002160601009

1. This failure code is displayed when the engine speed of 4,000 r/min or more is detected. While this failure code is detected, fuel injection is stopped. When the engine speed is lower than 3,800 r/min., fuel injection is resumed.

NOTICE

- The objective of this failure code is not to detect overrun due to failure of this system, but to memorize high revolution of the engine. (Detection of shifting error)
- Engine speed may be incorrectly recognized with noise on the speed sensor signal due to harness failure or modification, resulting in detection of overrun.

Fuel temperature sensor malfunction (DTC code P0182, P0183/diagnosis monitor code 14)

JP30002160601010

DTC	P0182	Fuel temperature sensor circuit low input
DTC	P0183	Fuel temperature sensor circuit high input

1 Measurement of resistance between terminals

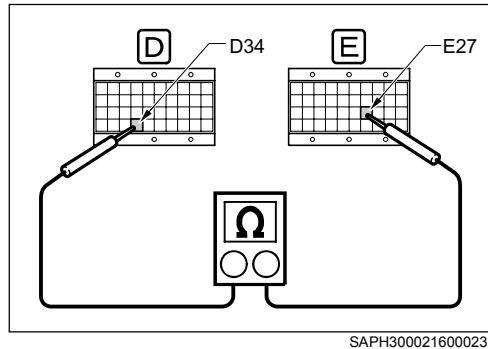

1. Set the starter key to "LOCK" and connect the signal check harness.
2. Disconnect the ECU side connector of the signal check harness and measure the resistance between terminal E27 and terminal D34.

Standard value (Measure either one point of the following.)

- : 2.45 k Ω (Fuel temperature at 20 °C{68 °F})
- : 1.15 k Ω (Fuel temperature at 40 °C{104 °F})
- : 584 Ω (Fuel temperature at 60 °C{140 °F})
- : 318 Ω (Fuel temperature at 80 °C{176 °F})

NG

[2] Go to measurement of resistance between terminals.

OK

Engine ECU failure, ECU connector failure, harness short-circuit

2 Measurement of sensor resistance

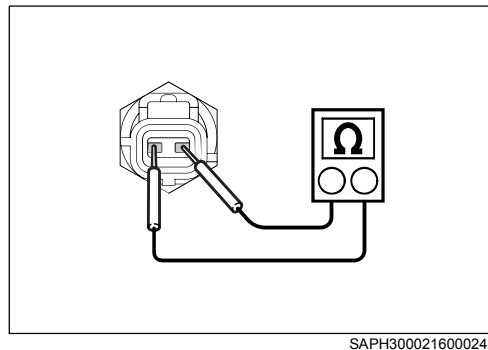

1. Disconnect the connector of the fuel temperature sensor and measure the resistance between No. 1 and No. 2 terminals at the sensor.

Standard value (Measure either one point of the following.)

- : 2.45 k Ω (Fuel temperature at 20 °C{68 °F})
- : 1.15 k Ω (Fuel temperature at 40 °C{104 °F})
- : 584 Ω (Fuel temperature at 60 °C{140 °F})
- : 318 Ω (Fuel temperature at 80 °C{176 °F})

NG

Failure of fuel temperature sensor

OK

Harness disconnection, connector failure

Boost pressure sensor malfunction (DTC code P0108, P0237/diagnosis monitor code 37)

JP30002160601011

DTC	P0108	Boost pressure sensor circuit high input
DTC	P0237	Boost pressure sensor circuit low input

1 Measurement of voltage between sensor terminals

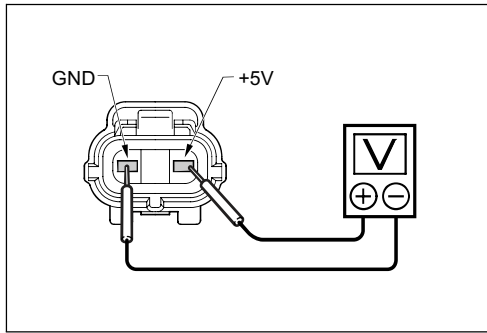

1. Set the starter key to "LOCK" and connect the signal check harness.
2. Disconnect the connector of the boost pressure sensor.
3. Set the starter key to "ON" and measure voltage between the +5V terminal and the GND terminal of the boost pressure sensor connector (at vehicle harness side).

Standard value : 5 ± 0.5 V

NG

[2] Go to measurement of voltage between terminals.

OK

[3] Go to measurement of voltage between terminals.

2 Measurement of voltage between terminals

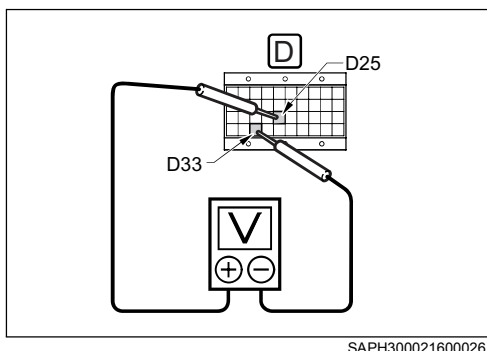

1. Measure the voltage between terminal D25 and terminal D33 of the signal check harness.

Standard value : 5 ± 0.5 V

NG

Engine ECU failure, ECU connector failure

OK

Harness failure

3 Measurement of voltage between terminals

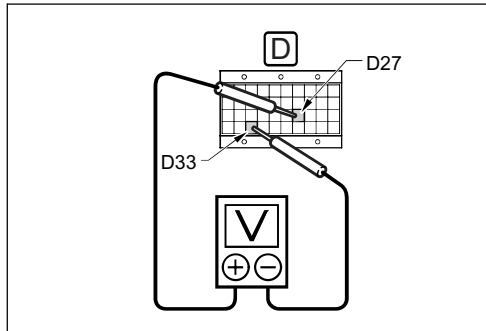

1. Set the starter key to "LOCK" and connect the connector of the boost pressure sensor.
2. Set the starter key to "ON" and measure the voltage between terminal D27 and terminal D33 of the signal check harness.

Standard value : 0.2 to 4.8 V

NG

[4] Go to measurement of voltage between terminals.

OK

Engine ECU failure, ECU connector failure

4 Measurement of voltage between sensor terminals

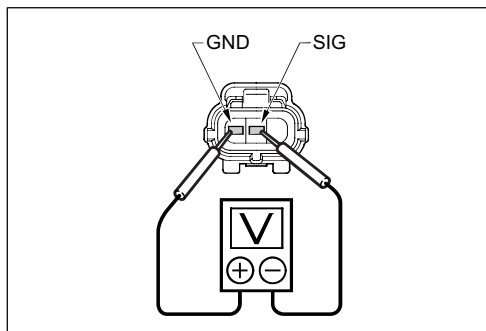

1. Leave the connector of the boost pressure sensor connected.
2. Measure the voltage between the SIG terminal and the GND terminal of the boost pressure sensor connector (at vehicle harness side).

Standard value : 0.2 to 4.8 V

NG

Boost pressure sensor failure

OK

Harness failure

Turbocharger over boost (DTC code P0234/diagnosis monitor code 39)

JP30002160601012

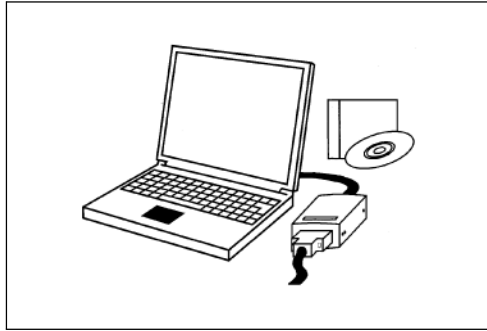
1 Inspection with failure diagnosis tool

SAPH300021600004

1. After failure, perform failure diagnosis with a failure diagnosis tool (HINO field support system) using PC.
2. Connect the failure diagnosis tool (HINO field support system) using PC and set the starter key to "ON".

OK

Perform diagnosis of the boost pressure sensor (DTC code P0108, P0237/diagnosis monitor code 37).
 "Reference : 3-6, Failure diagnosis using DST-1, Engine ECU, Engine diagnosis code"

Excessive common rail pressure (DTC code P0088/diagnosis monitor code 68, 69)

JP30002160601013

DTC	P0088	diagnosis monitor code	68	Excessive common rail pressure (1st step)
DTC	P0088	diagnosis monitor code	69	Excessive common rail pressure (2nd step)

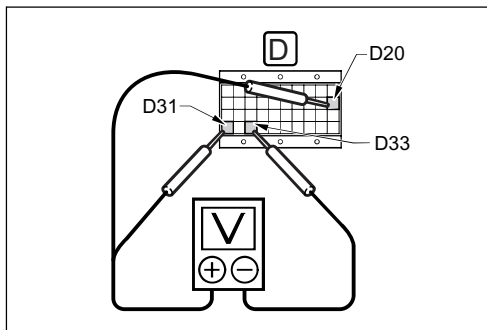
1 Measurement of voltage between terminals

SAPH300021600029

1. Set the starter key to "LOCK" and connect the signal check harness.
2. Set the starter key to "ON" and measure the voltage between terminals D20/D31 and terminal D33 of the signal check harness.

Standard value : 3.6 to 4.7 V

NG

Engine ECU failure or harness/connector contact failure

OK

Failure of common rail pressure sensor

Excessive common rail pressure, supply pump excess forced feed (DTC code P0088/diagnosis monitor code 76)

JP30002160601014

1 Measurement of voltage between terminals

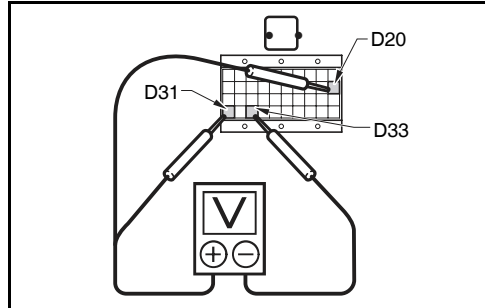

SAPH300021600030

1. Set the starter key to "LOCK" and connect the signal check harness.
2. Start and warm-up the engine until the coolant temperature gauge moves.
3. Set the engine speed to idling. PFIN = Approx. 30 MPa (approx. 1.5V)
4. Measure the voltage between terminal D20/D31 and terminal D33 of the signal check harness.

Standard value : 1.56 V or less

NG

Failure of common rail pressure sensor

OK

2 Check of failure code

1. Make sure that other failure code is not output.
If other failure code is output, repair the failure code and make sure again that DTC code P0088/diagnosis monitor code 76 is output. In particular, if a failure code of the main and sub-engine speed sensor systems is output, make necessary repairs to prevent output of the code.
2. Check the fuel injection timing of the supply pump. If the timing is not set 0° for the top dead center, set it correctly.
3. When there is no error after the check above, delete the past failure using DST-1 and start the engine.
If the same code is output again, possible failures are the supply pump, common rail pressure sensor system and engine ECU. Perform more detailed diagnosis with failure diagnosis tool (HINO field support system) using PC.

Common rail pressure sensor malfunction (DTC code P0191/diagnosis monitor code 67)

JP30002160601015

1 Measurement of voltage between terminals

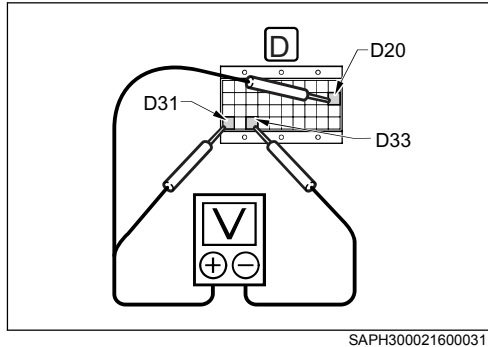

1. Set the starter key to "LOCK" and connect the signal check harness.
2. Set the starter key to "ON" and measure the voltage between terminals D20/D31 and terminal D33.

Standard value : 0.9 to 1.1 V

NG

Engine ECU failure or harness/connector contact failure

OK

2 Measurement of voltage between terminals

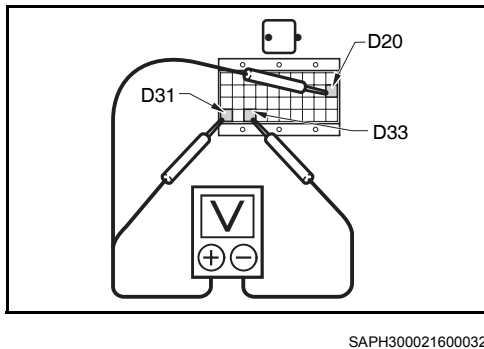

1. Start the engine.
2. While measuring the voltage between terminals D20/D31 and terminal D33 of the signal check harness, repeat full opening/closing of the accelerator.

Standard : Voltage must change. (1.0 to 3.2 V)

NG

Common rail pressure sensor failure or harness/connector contact failure

OK

Engine ECU failure, connector contact failure

Common rail pressure sensor failure (DTC code P0192, P0193/diagnosis monitor code 67)

JP30002160601016

DTC	P0192	Common rail pressure sensor circuit low input
DTC	P0193	Common rail pressure sensor circuit high input

1 Measurement of voltage between terminals

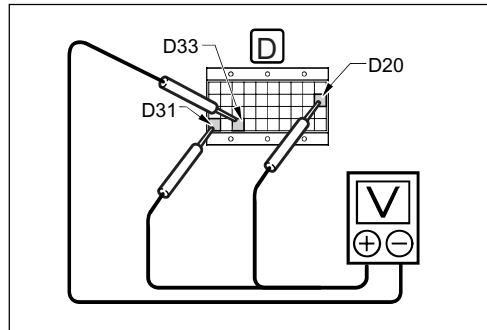

1. Set the starter key to "LOCK" and connect the signal check harness.
2. Set the starter key to "ON" and measure the voltage between terminals D20/D31 and terminal D33 of the signal check harness.

Standard value : 0.7 to 4.7 V

NG

[2] Go to measurement of voltage between terminals.

OK

Engine ECU failure, ECU connector failure

2 Measurement of voltage between sensor terminals

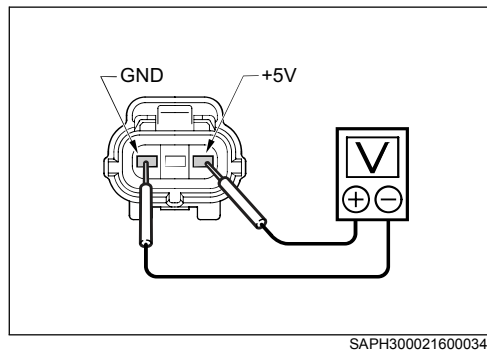

1. Set the starter key to "LOCK" and disconnect the connector of the common rail pressure sensor.
2. Set the starter key to "ON" and measure voltage between the +5V terminal and the GND terminal of the common rail pressure sensor connector (at vehicle harness side).

Standard value : 5 ± 0.5 V

NG

[4] Go to measurement of resistance between terminals.

OK

3 Measurement of resistance between terminals

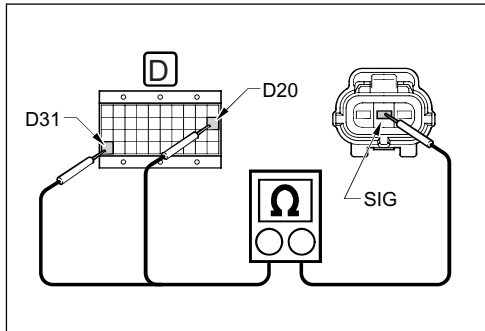

1. Set the starter key to "LOCK" and disconnect the ECU side connector of the signal check harness.
2. Measure the resistance between terminals D20/D31 of the signal check harness and the SIG terminal of the common rail pressure sensor connector (at vehicle harness side).

Standard value : 2 Ω or less

NG

Harness failure

OK

Connector contact failure

4 Measurement of resistance between terminals

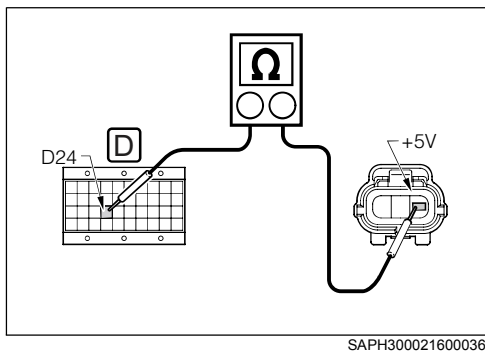

1. Set the starter key to "LOCK" and disconnect the ECU side connector of the signal check harness.
2. Measure the resistance between terminals D24 of the signal check harness and the +5 V terminal of the common rail pressure sensor connector (at vehicle harness side).

Standard value : 2 Ω or less

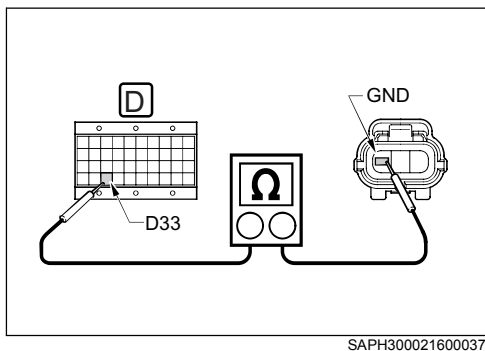

3. Measure the resistance between terminal D33 of the signal check harness and the GND terminal of the common rail pressure sensor connector (at vehicle harness side).

Standard value : 2 Ω or less

NG

Harness failure

OK

Engine ECU failure, ECU connector failure

Accelerator sensor 1 malfunction (DTC code P2121/diagnosis monitor code 22)

JP30002160601017

1 Measurement of voltage between sensor terminals

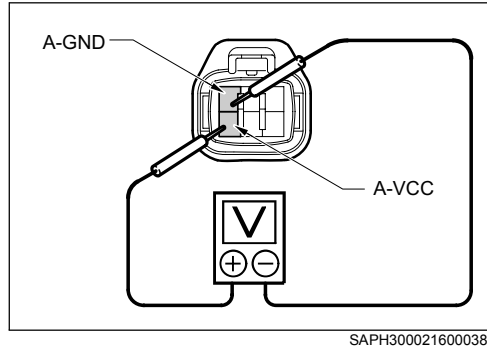

1. Set the starter key to "LOCK" and connect the signal check harness.
2. Disconnect the connector of the accelerator sensor and set the starter key to "ON".
3. Measure the voltage between the A-VCC terminal and the A-GND terminal of the accelerator sensor connector (at vehicle harness side).

Standard value : 5 ± 0.5 V

NG

[2] Go to measurement of voltage between terminals.

OK

[3] Go to measurement of voltage between terminals.

2 Measurement of voltage between terminals

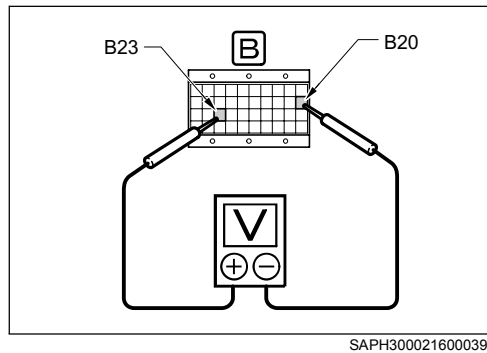

1. Measure voltage between terminal B23 and terminal B20 of the signal check harness.

Standard value : 5 ± 0.5 V

NG

Engine ECU failure, ECU connector failure

OK

Harness failure

3 Measurement of voltage between terminals

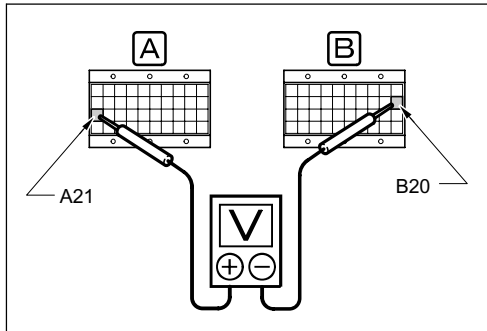

SAPH300021600040

1. Set the starter key to "LOCK" and connect the connector of the accelerator sensor.
2. Set the starter key to "ON" and measure the voltage between terminal A21 and terminal B20 of the signal check harness.

CAUTION • The standard value in full throttle status is based on the actual measurement value.

Standard value

- : 0.7 V or less (idle status)
- : 3.55 to 4.4 V (full throttle status)

NG

[4] Go to measurement of voltage between terminals.

OK

Engine ECU failure, ECU connector failure

4 Measurement of voltage between sensor terminals

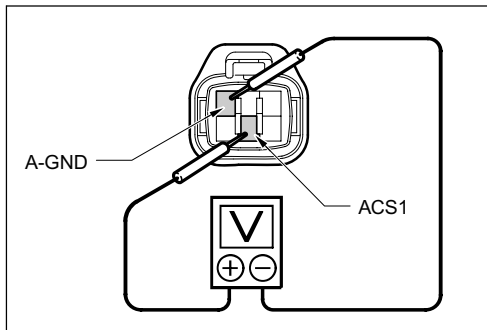

SAPH300021600041

1. Leave the connector of the accelerator sensor connected.
2. Measure the voltage between the ACS1 terminal and the A-GND terminal of the accelerator sensor connector (at vehicle harness side).

CAUTION • The connector in the figure is viewed from the fitting surface.

- The standard value in full throttle status is based on the actual measurement value.

Standard value

- : 0.7 V or less (idle status)
- : 3.55 to 4.4 V (full throttle status)

NG

Accelerator sensor failure

OK

Disconnection or short-circuit of harness

Accelerator sensor 1 malfunction (DTC code P2122, P2123/diagnosis monitor code 22)

JP30002160601018

DTC	P2122	Accelerator sensor circuit 1 low voltage
DTC	P2123	Accelerator sensor circuit 1 high voltage

1 Measurement of voltage between terminals

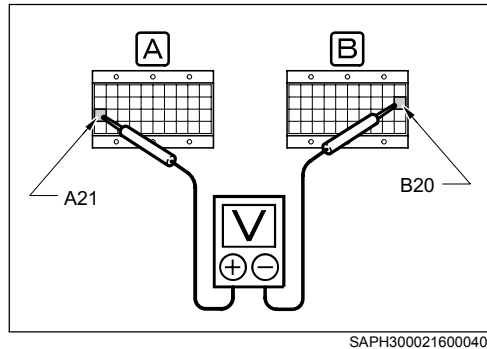

1. Set the starter key to "LOCK" and connect the signal check harness.
2. Set the starter key to "ON" and measure the voltage between terminal A21 and terminal B20 of the signal check harness.

Standard value : 0.7 V or less (idle status)

NG

Accelerator sensor failure

OK

2 Measurement of voltage between terminals

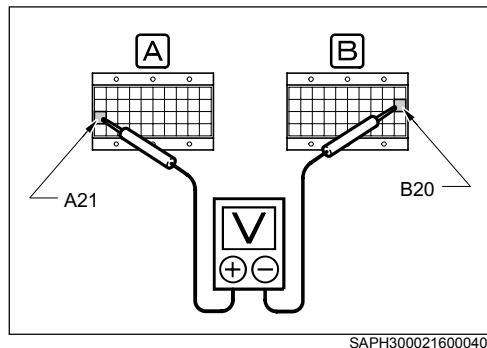

1. While depressing the accelerator pedal, measure the voltage between terminal A21 and terminal B20 of the signal check harness.

Standard value
: Voltage must change in proportion to depression of the accelerator pedal at 1.0V or more.

NG

Accelerator sensor failure

OK

Harness failure

Accelerator sensor 2 malfunction (DTC code P2126/diagnosis monitor code 22)

JP30002160601019

1 Measurement of voltage between sensor terminals

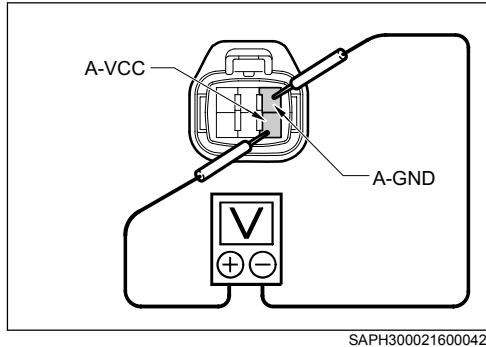

1. Set the starter key to "LOCK" and connect the signal check harness.
2. Disconnect the connector of the accelerator sensor and set the starter key to "ON".
3. Measure the voltage between the A-VCC terminal and the A-GND terminal of the accelerator sensor connector (at vehicle harness side).

Standard value : 5 ± 0.5 V

NG

[2] Go to measurement of voltage between terminals.

OK

[3] Go to measurement of voltage between terminals.

2 Measurement of voltage between terminals

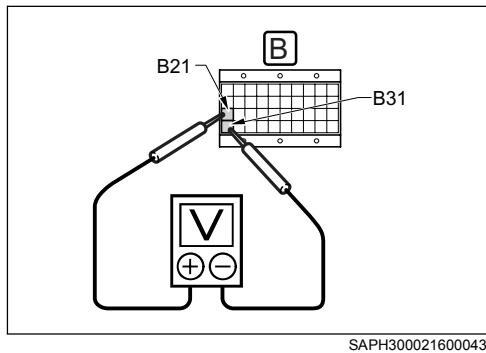

1. Measure voltage between terminal B31 and terminal B21 of the signal check harness.

Standard value : 5 ± 0.5 V

NG

Engine ECU failure, ECU connector failure

OK

Harness failure

3 Measurement of voltage between terminals

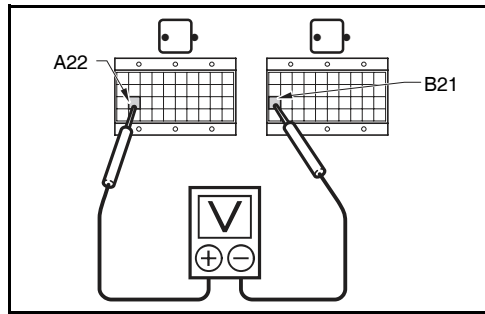

SAPH300021600044

1. Set the starter key to "LOCK" and connect the connector of the accelerator sensor.
2. Set the starter key to "ON" and measure the voltage between terminal A22 and terminal B21 of the signal check harness.

⚠ CAUTION • The standard value in full throttle status is based on the actual measurement value.

Standard value

- : 0.7 V or less (idle status)
- : 3.55 to 4.4 V (full throttle status)

NG

[4] Go to measurement of voltage between terminals.

OK

Engine ECU failure, ECU connector failure

4 Measurement of voltage between sensor terminals

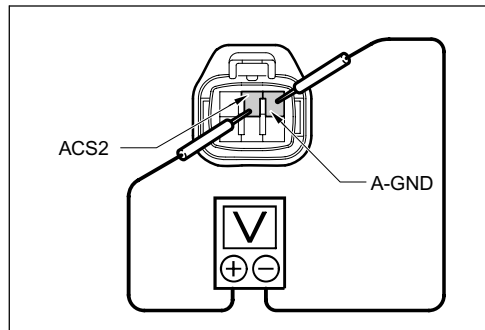

SAPH300021600045

1. Leave the connector of the accelerator sensor connected.
2. Measure the voltage between the ACS2 terminal and the A-GND terminal of the accelerator sensor connector (at vehicle harness side).

⚠ CAUTION • The connector in the figure is viewed from the fitting surface.

- The standard value in full throttle status is based on the actual measurement value.

Standard value

- : 0.7 V or less (idle status)
- : 3.55 to 4.4 V (full throttle status)

NG

Accelerator sensor failure

OK

Disconnection or short-circuit of harness

Accelerator sensor 2 malfunction (DTC code P2127, P2128/diagnosis monitor code 22)

JP30002160601020

DTC	P2127	Accelerator sensor circuit 2 low voltage
DTC	P2128	Accelerator sensor circuit 2 high voltage

1 Measurement of voltage between terminals

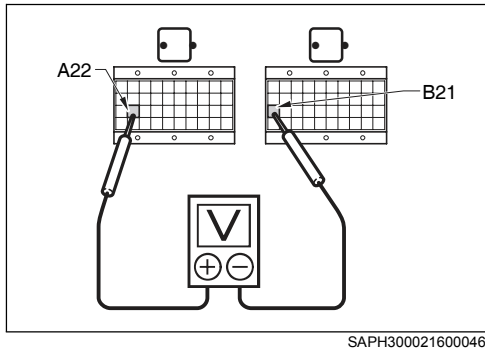

1. Set the starter key to "LOCK" and connect the signal check harness.
2. Set the starter key to "ON" and measure the voltage between terminal A22 and terminal B21 of the signal check harness.

Standard value : 0.7 V or less (idle status)

NG

Accelerator sensor failure

OK

2 Measurement of voltage between terminals

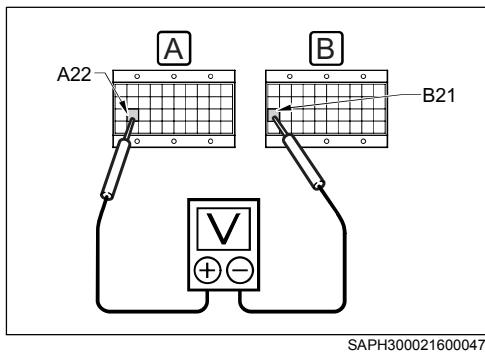

1. While depressing the accelerator pedal, measure the voltage between terminal A22 and terminal B21 of the signal check harness.

Standard value

: Voltage must change in proportion to depression of the accelerator pedal at 1.0 V or more.

NG

Accelerator sensor failure

OK

Harness failure

Accelerator sensor 1 and 2 malfunction (DTC code P2120/diagnosis monitor code 22)

JP30002160601021

1	Inspection item
---	-----------------

1. Take action of DTC code P2120/diagnosis monitor code 22.
 "Reference : 1-101/Common rail system/Accelerator sensor 1 voltage error (diagnosis code P2121)"
 "Reference : 1-104/Common rail system/Accelerator sensor 2 voltage error (diagnosis code P2126)"
 "Reference : Accelerator sensor 1 malfunction (DTC code P2121/ diagnosis monitor code 22), Engine ECU, Engine diagnosis code"
 "Reference : Accelerator sensor 2 malfunction (DTC code P2126/ diagnosis monitor code 22), Engine ECU, Engine diagnosis code"

Atmospheric pressure sensor malfunction (DTC code P2228, P2229/ diagnosis monitor code 15)

JP30002160601022

DTC	P2228	Atmospheric pressure sensor circuit low input
DTC	P2229	Atmospheric pressure sensor circuit high input

1	Check of diagnosis code
---	-------------------------

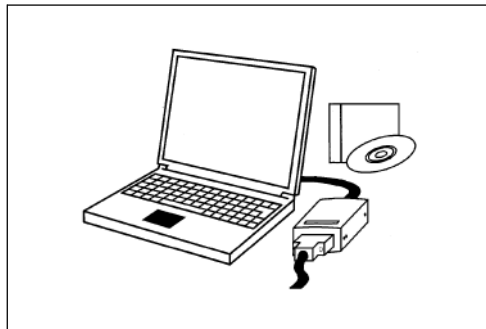

SAPH300021600004

1. After deleting the past failures with the failure diagnosis tool (HINO field support system) using PC, check again if the same code (DTC code P2228, P2229/diagnosis monitor code 15) is output.

Standard : Normal

NG

Engine ECU failure

OK

Since it may be a temporary malfunction due to radio interference, it is acceptable when the system recovers normal operation.

Injector common 1 short to GND (DTC code P1211/diagnosis monitor code 57), Injector common 2 short to GND (DTC code P1214/diagnosis monitor code 58)

JP30002160601023

1 Measurement of resistance between terminals

1. Set the starter key to "LOCK" and connect the signal check harness.
2. Disconnect the ECU side connector of the signal check harness.
3. Measure the resistance between each terminal of the signal check harness and the ECU case ground.

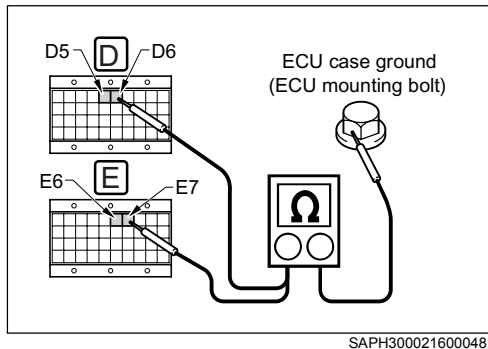

Failure code		Terminal to measure resistance	
DTC code	Diagnosis monitor code		
P1211	57	D5, D6	ECU case ground
P1214	58	E6, E7	ECU case ground

Standard value : $\infty\Omega$

NG

[3] Go to measurement of resistance between injector terminals.

OK

2 Check of diagnosis code

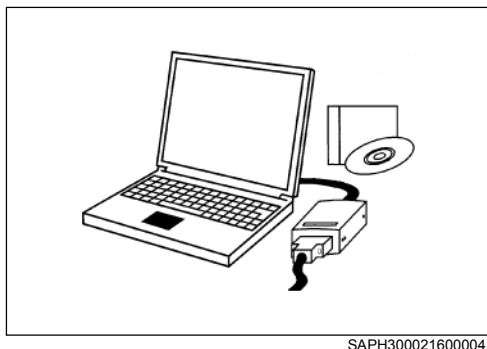

1. Set the starter key to "LOCK" and connect the ECU side connector of the signal check harness.
2. Start the engine and delete the past failures with the failure diagnosis tool (HINO field support system) using PC.
3. If the same failure code is output again, replace the engine ECU. If the normal code is output, it is considered that a temporary error has occurred.

3

Measurement of resistance between injector terminals

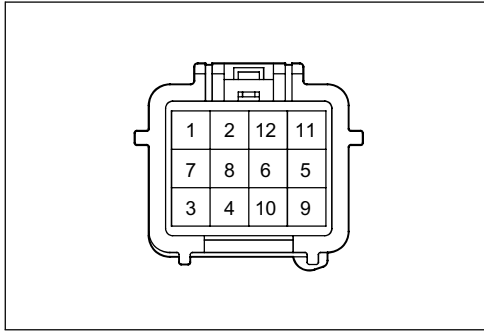

SAPH300021600049

1. Set the starter key to "LOCK".
2. Tilt the cab and disconnect the injector clustered connector at the front of the cam housing.
3. Measure the resistance between terminals of the injector clustered connector (at vehicle harness side).

Failure code		Terminal to measure resistance	
DTC code	Diagnosis monitor code	+ side	- side
P1211	57	7, 8, 9, 10, 11, 12	ECU case ground
P1214	58	5, 6, 1, 2, 3, 4	ECU case ground

Standard value : $\infty\Omega$

NG

Harness failure (failure including pinching of harness which has not satisfied the standard value)

OK

Inspection of harness inside head cover (Short-circuit of the harness inside the head cover to the ground line may have occurred.)

Injector common 1 short to BATT (DTC code P1212/diagnosis monitor code 57), Injector common 2 short to BATT (DTC code P1215/diagnosis monitor code 58)

JP30002160601024

1 Measurement of voltage between terminals

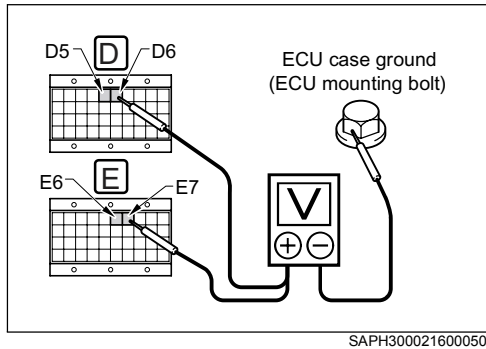

1. Set the starter key to "LOCK" and connect the signal check harness.
2. Disconnect the ECU side connector of the signal check harness and set the starter key to "ON".
3. Measure the voltage between each terminal of the signal check harness and the ECU case ground.

CAUTION • Never start the engine because it may cause failure of the unit or electric shock.

Failure code		Terminal to measure voltage	
DTC code	Diagnosis monitor code	+ side	- side
P1212	57	D5, D6	ECU case ground
P1215	58	E6, E7	ECU case ground

Standard value : 14 V or less

NG

[3] Go to measurement of voltage between injector terminals.

OK

2 Check of diagnosis code

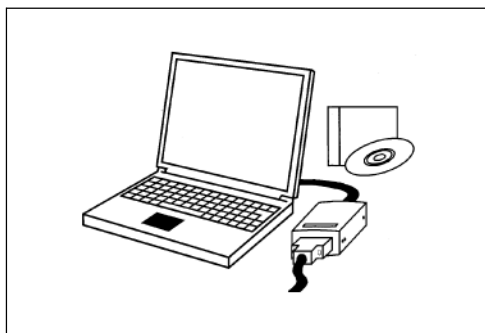

1. Set the starter key to "LOCK" and connect the ECU side connector of the signal check harness.
2. Start the engine and delete the past failures with the failure diagnosis tool (HINO field support system) using PC.
3. If the same failure code is output again, replace the common rail ECU. If the normal code is output, it is considered that a temporary error has occurred.

3 Measurement of voltage between injector terminals

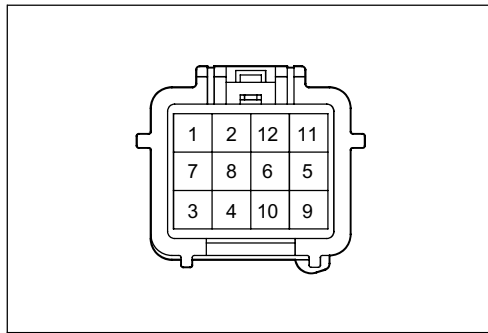

SAPH300021600049

1. Set the starter key to "LOCK".
2. Disconnect the injector clustered connector at the front of the cam housing and set the starter key to "ON".
3. Measure the voltage between terminals of the injector clustered connector (at vehicle harness side).

! CAUTION • Never start the engine because it may cause failure of the unit or electric shock.

Failure code		Terminal to measure voltage	
DTC code	Diagnosis monitor code	+ side	- side
1212	57	8, 10, 12	ECU case ground
1215	58	2, 4, 6	ECU case ground

Standard value : 14 V or less

NG → **Harness failure (harness failure of terminal that has not satisfied the standard value)**

OK

Inspection of harness inside head cover (Short-circuit of the harness inside the head cover to the power line may have occurred.)

Injector circuit malfunction (DTC code P0201 to P0206/diagnosis monitor code 51 to 56)

JP3000216061025

DTC	P0201	Injector circuit malfunction -cylinder 1
DTC	P0202	Injector circuit malfunction -cylinder 2
DTC	P0203	Injector circuit malfunction -cylinder 3
DTC	P0204	Injector circuit malfunction -cylinder 4
DTC	P0205	Injector circuit malfunction -cylinder 5
DTC	P0206	Injector circuit malfunction -cylinder 6

1 Measurement of resistance between terminals

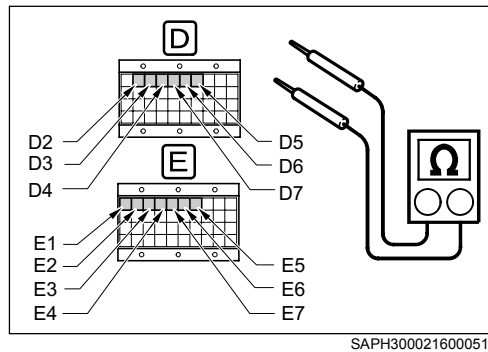

1. Set the starter key to "LOCK" and connect the signal check harness.
2. Disconnect the ECU side connector of the signal check harness and measure the resistance between terminals.

Failure code	Failure area (injector)	Terminal to measure resistance
P0201 (51)	# 1	D2 ↔ D5
P0202 (52)	# 2	D3 ↔ D5
P0203 (53)	# 3	D4 ↔ D6
P0204 (54)	# 4	E1 ↔ E6
P0205 (55)	# 5	E3 ↔ E6
P0206 (56)	# 6	E2 ↔ E7

Standard value : 2 Ω or less

NG

[3] Go to measurement of resistance between injector terminals.

OK

2 Check of diagnosis code

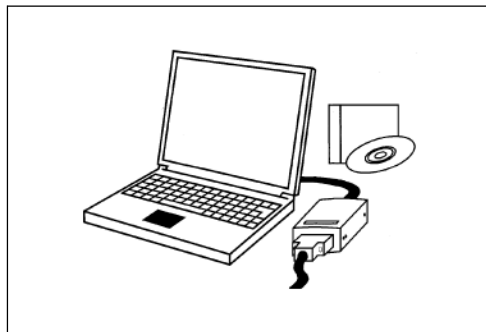

1. Set the starter key to "LOCK" and connect the ECU side connector of the signal check harness.
2. Start the engine and delete the past failures with the failure diagnosis tool (HINO field support system) using PC.
3. If the same failure code is output again, replace the common rail ECU. If the normal code is output, it is considered that a temporary error has occurred.

3 Measurement of resistance between injector terminals

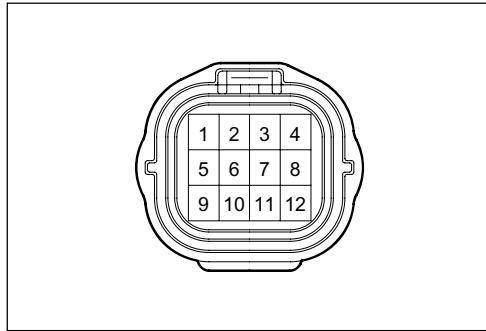

SAPH300021600052

1. Tilt the cab and disconnect the injector clustered connector at the front of the cam housing.
2. Measure the resistance between terminals of the injector clustered connector (male) at the cam housing.

Failure code		Terminal to measure resistance
DTC code	Diagnosis monitor code	
P0201	51	9 ↔ 10
P0202	52	1 ↔ 2
P0203	53	7 ↔ 8
P0204	54	5 ↔ 6
P0205	55	3 ↔ 4
P0206	56	11 ↔ 12

Standard value : 2 Ω or less

NG

[4] Go to measurement of resistance between injector terminals.

OK

Vehicle harness disconnection (Check the harness between the ECU and the injector clustered connector.)

4 Measurement of resistance between injector terminals

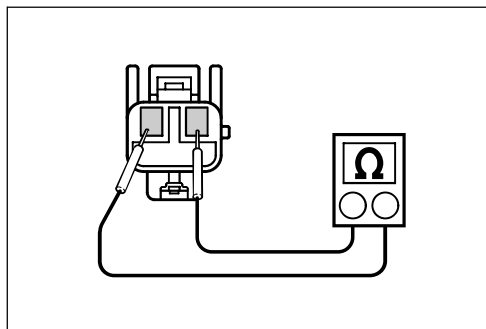

SAPH300021600053

1. Remove the head cover and disconnect the injector connector (injector side) of the cylinder indicated by the failure code. Measure the resistance between the No. 1 terminal and the No. 2 terminal.

Standard value : 0.45 ± 0.05 Ω

NG

[5] Go to measurement of resistance between injector terminals.

OK

Contact failure of harness or connector inside the head cover

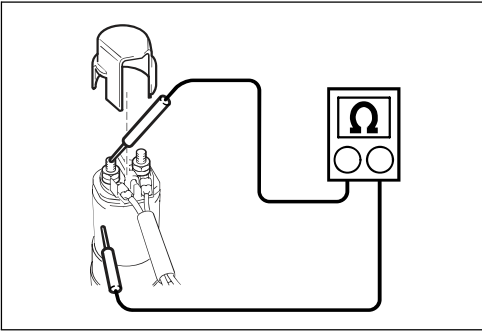
5 Measurement of resistance between injector terminals

1. Remove the terminal cap of the injector of the cylinder indicated by the failure code and measure the insulation resistance between the terminal and the upper body.

Standard value : 1, 000 MΩ or less

NG

Injector TWV coil disconnection (Replace the injector assembly.)

OK

Injector harness disconnection (Replace the injector harness.)

Cylinder contribution/balance fault (DTC codes P0263, P0266, P0269, P0272, P0275, P0278/diagnosis monitor code 61 to 66)

JP30002160601026

DTC	P0263	Cylinder 1 contribution/balance fault
DTC	P0266	Cylinder 2 contribution/balance fault
DTC	P0269	Cylinder 3 contribution/balance fault
DTC	P0272	Cylinder 4 contribution/balance fault
DTC	P0275	Cylinder 5 contribution/balance fault
DTC	P0278	Cylinder 6 contribution/balance fault

1 Inspection of flow damper 1

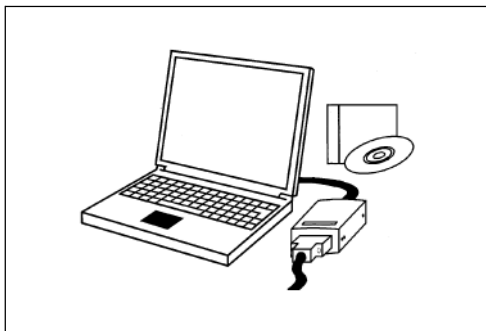

SAPH300021600004

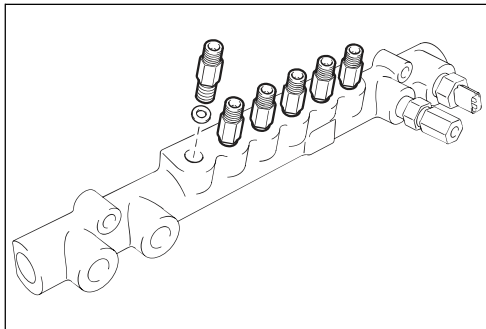

SAPH300021600055

1. Set the starter key to "LOCK" and stop the engine.
2. Wait for approx. 30 seconds and start the engine.
3. Warm-up the engine until coolant temperature is 60 °C{140 °F} or more, delete the past failure with a failure diagnosis tool (HINO field support system) using PC.
4. If the same failure code is displayed as the current failure after deleting the past failure, check the flow damper of the cylinder indicated by the failure code.

Failure code		Failure area (Flow damper)
DTC code	Diagnosis monitor code	
P0263	61	# 1
P0266	62	# 2
P0269	63	# 3
P0272	64	# 4
P0275	65	# 5
P0278	66	# 6

2 Inspection of flow damper 2

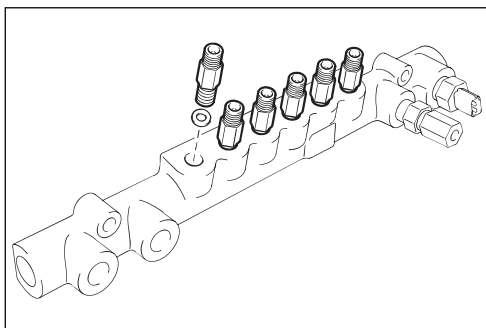

SAPH300021600056

1. Remove the flow damper from the common rail and run air from one side of the flow damper. Check if the damper is not blocked by release of air to the opposite side.

CAUTION • When air is run, be careful so that dirt, water, etc. may not enter the flow damper.

Standard value : Air must flow. (Flow damper is normal.)

NG

Replace the flow damper (if air is not run)

OK

3

Check of failure code

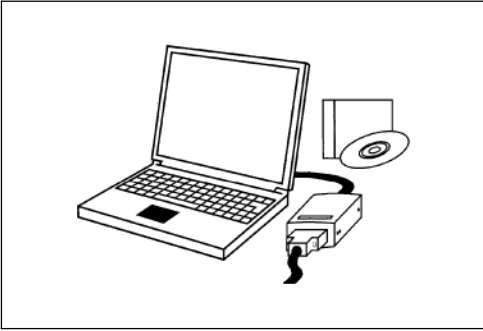

SAPH300021600004

1. Make sure that other failure code is not output.
If other failure code is output, repair the failure first and delete the past failure with the failure diagnosis tool (HINO field support system) using PC.
Then, if this failure code is output again, the following failures may be estimated.
 - Excessive fuel flow due to leak from broken pipe, crack in pipe or pipe connection between the flow damper and the injector pipe
→Check for leak
 - Too large or too small fuel flow due to increase of leak inside inside the injector
→Check for leak on the individual injector with a nozzle tester
 - Excessive fuel flow due to failure of injection nozzle and seat
→Check for seat failure on the individual injector with a nozzle tester
 - Too large or too small fuel flow due to malfunction of the injector
→Check with replacement of injector
 - Too small fuel flow due to clogging in the fuel supply system
→Inspection of fuel filter

2. To specify a failure location above, check the compensation between cylinders with the failure diagnosis tool (HINO field support system) using PC and stop an injector. Then, perform diagnosis while viewing the engine data.

SCV malfunction (DTC code P0628, P0629/diagnosis monitor code 74)

JP30002160601027

DTC	P0628	SCV malfunction
DTC	P0629	SCV out put short to BATT

1 Measurement of resistance between solenoid terminals

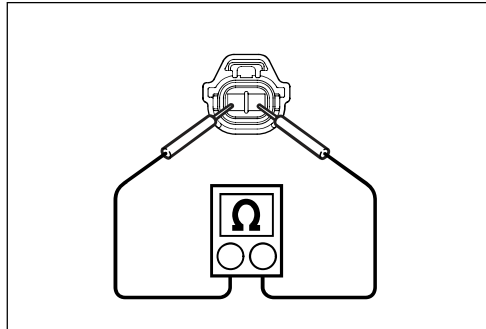

SAPH300021600057

1. Set the starter key to "LOCK", disconnect the connector of the supply pump solenoid valve and measure the resistance between No. 1 and No. 2 terminals at the supply pump solenoid valve.

Standard value : $7.9 \pm 0.5 \Omega$ (20 °C {68 °F})

NG

Failure of supply pump solenoid valve

OK

2 Measurement of resistance between terminals

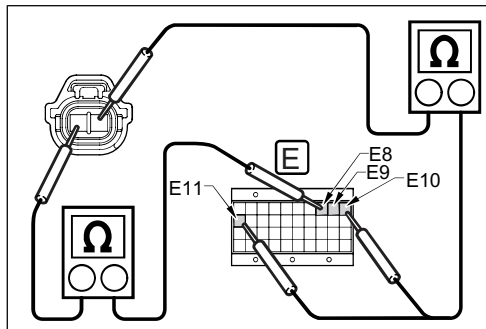

SAPH300021600058

1. Set the starter key to "LOCK", connect the signal check harness and disconnect the ECU side connector.
2. Measure the resistance between terminals E10/E11 of the signal check harness and the No. 1 terminal of the supply pump solenoid valve (at vehicle harness side).
In a similar manner, measure the resistance of terminals E8/E9 of the signal check harness and the No. 2 terminal of the supply pump solenoid valve connector (at vehicle harness side).

Standard value : 1 Ω or less

NG

Harness disconnection, connector failure

OK

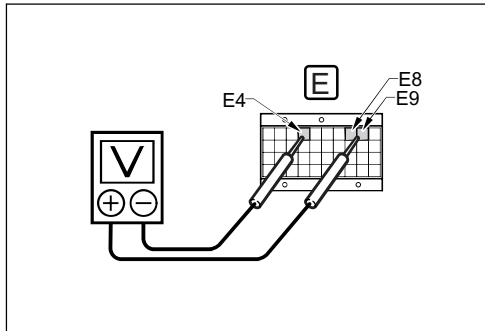
3 Measurement of voltage between terminals

1. Turn "ON" the starter key.
2. Measure voltage between terminal E4 and terminals E8/E9 of the signal check harness.

Standard value : Pulse waveform at 24V ↔ 0V

NG

Failure of ECU connector

OK

Engine ECU failure

⚠ CAUTION • After turning "ON" the starter key, take measurements within 40 seconds.

Supply pump SCV sticking (DTC code P2635/diagnosis monitor 75), Supply pump malfunction (DTC code P2635/diagnosis code 77), Supply pump abnormal pressure record (DTC code P2635/diagnosis monitor code 79)

JP30002160601028

1 Inspection of supply pump

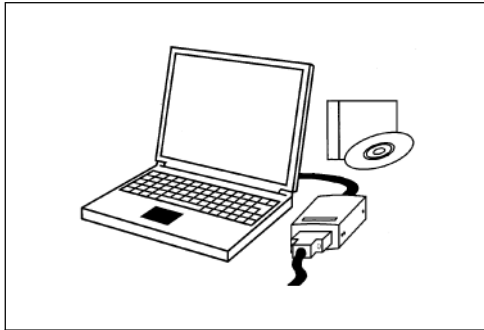

SAPH300021600004

1. Set the starter key to "LOCK" and stop the engine.
2. Wait for approx. 30 seconds and start the engine.
3. Warm-up the engine until coolant temperature is 60 °C{140 °F} or more, and delete the past failure with the failure diagnosis tool (HINO field support system) using PC.
4. Check if the same failure code is displayed as the current failure when the engine is operated to NMR or raced.

NG

Replace supply pump.

OK

2 Check of failure code

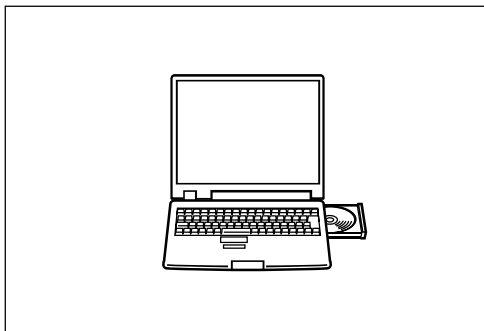

SAPH300021600060

1. Make sure that other failure code is not output.
If other failure code is output, repair the failure code and make sure again that DTC code P2635 is output.
2. When there is no error after the check above, delete the past failure and operate the engine.
If the same code is output again, possible failures are the supply pump and engine ECU. Perform more detailed diagnosis with failure diagnosis tool (HINO field support system) - Hino DX [Inspection Menu], using PC.

EGR solenoid 1 malfunction (DTC code P0489, P0490/diagnosis monitor code 81)

JP30002160601029

1 Measurement of voltage between terminals

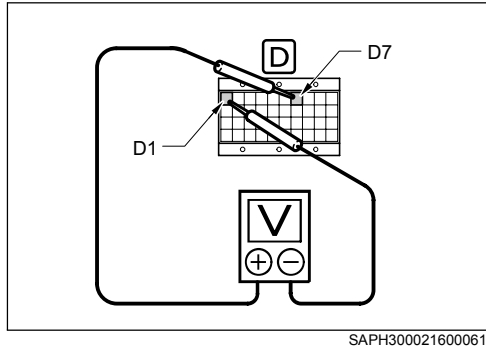

1. Set the starter key to "LOCK" and remove the signal check harness.
2. Set the starter key to "ON" and measure the voltage between terminal D7 and terminal D1 of the signal check harness.

Standard value : 19 V or more

NG

Engine ECU failure, ECU connector failure, harness short-circuit

OK

2 Measurement of voltage between solenoid valve terminals

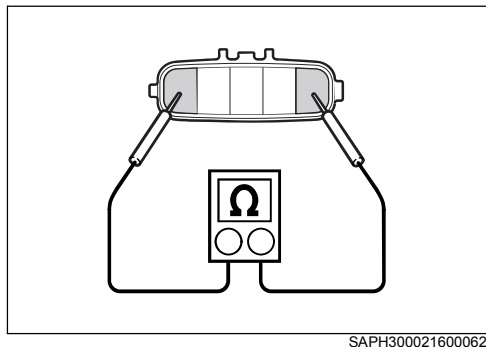

1. Set the starter key to "LOCK", disconnect the connector of the EGR solenoid valve 1 and measure the resistance between No. 1 and No. 5 terminals at the EGR solenoid valve.

Standard value : $27.5 \pm 2 \Omega$ (20 °C {68° F})

NG

Failure of EGR solenoid valve 1

OK

3 Measurement of resistance between terminals

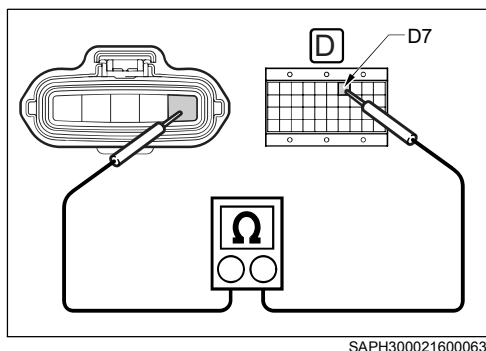

1. Set the starter key to "LOCK" and disconnect the ECU side connector of the signal check harness.
2. Measure the resistance between terminal D7 of the signal check harness and the connector (No. 5 terminal at the vehicle side connector) of the EGR solenoid valve 1.

Standard value : 1 Ω or less

NG

Harness disconnection, connector failure

OK

Connection failure of connector

EGR solenoid 2 malfunction (DTC code P1402, P1403/diagnosis monitor code 82)

JP3000216061030

1 Measurement of voltage between terminals

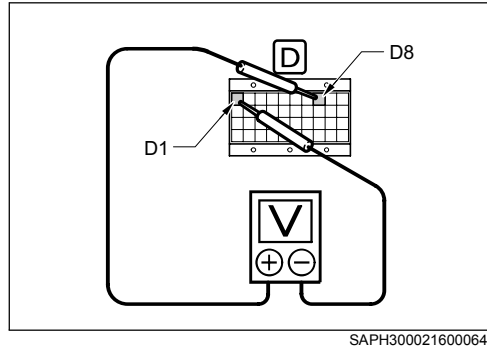

1. Set the starter key to "LOCK" and connect the signal check harness.
2. Set the starter key to "ON" and measure the voltage between terminal D8 and terminal D1 of the signal check harness.

Standard value : 19 V or more

NG

Engine ECU failure, ECU connector failure, harness short-circuit

OK

2 Measurement of voltage between solenoid valve terminals

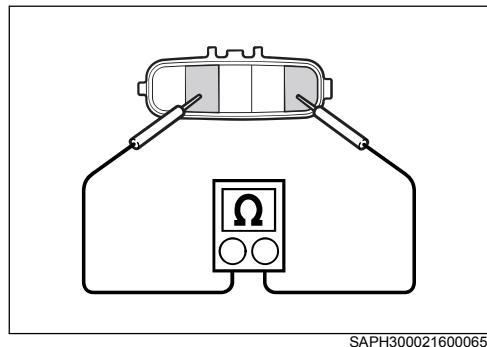

1. Set the starter key to "LOCK", disconnect the connector of the EGR solenoid valve 2 and measure the resistance between No. 2 and No. 5 terminals at the EGR solenoid valve.

Standard value : $27.5 \pm 2 \Omega$ (20 °C {68° F})

NG

Failure of EGR solenoid valve 2

OK

3 Measurement of resistance between terminals

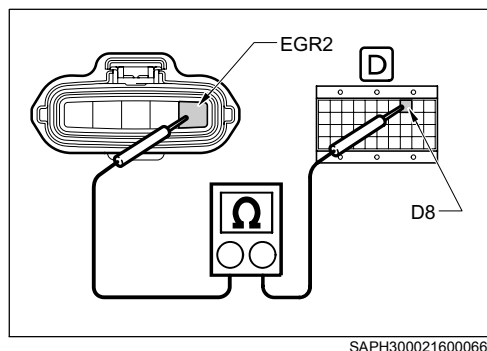

1. Set the starter key to "LOCK" and disconnect the ECU side connector of the signal check harness.
2. Measure the resistance between terminal D8 of the signal check harness and the connector (No. 5 terminal at the vehicle side connector) of the EGR solenoid valve 2.

Standard value : 1 Ω or less

NG

Harness disconnection, connector failure

OK

Connection failure of connector

EGR valve 1 stick (DTC code P0404/diagnosis monitor code 88)

JP30002160601031

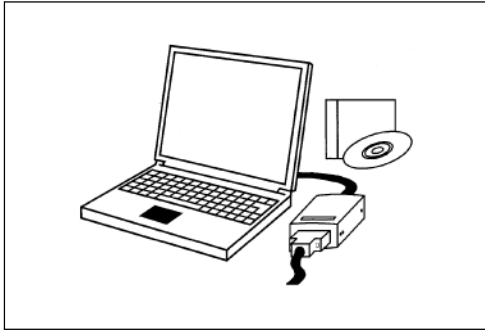
1 Inspection with PC

SAPH300021600004

1. After display of failure code, check EGR with the failure diagnosis tool (HINO field support system) using PC.
2. Connect the failure diagnosis tool (HINO field support system) using PC and set the starter key to "ON".
3. Make sure that there are no EGR solenoid valve 1 failure (DTC code P0489, P0490) and EGR lift sensor 1 failure (DTC code P0405, P0406).
4. Make sure that the actual opening follows the opening indicated on the EGR inspection screen.

Standard value : Within 5 % error

NG

EGR failure

OK

Normal

"Reference : 3-6, Failure diagnosis using DST-1, Engine ECU, Engine diagnosis code"

EGR valve 2 stick (DTC code P1401/diagnosis monitor code 89)

JP30002160601032

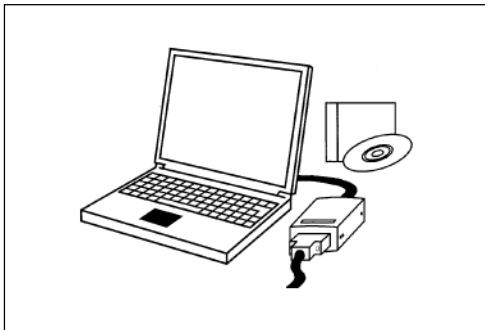
1 Inspection with PC

SAPH300021600004

1. After display of failure code, check EGR with the failure diagnosis tool (HINO field support system) using PC.
2. Connect the failure diagnosis tool (HINO field support system) using PC and set the starter key to "ON".
3. Make sure that there are no EGR solenoid valve 2 failure (DTC code P1402, P1403) and EGR lift sensor 2 failure (DTC code P0407, P0408).
4. Make sure that the actual opening follows the opening indicated on the EGR inspection screen.

Standard value : Within 5 % error

NG

EGR failure

OK

Normal

"Reference : 3-6, Failure diagnosis using DST-1, Engine ECU, Engine diagnosis code"

EGR lift sensor 1 malfunction (DTC code P0405, P0406/diagnosis monitor code 86)

JP30002160601033

DTC	P0405	EGR lift sensor 1 circuit low input
DTC	P0406	EGR lift sensor 1 circuit high input

1 Measurement of voltage between sensor terminals

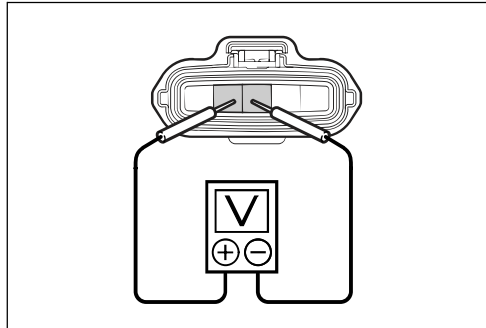

SAPH300021600067

1. Set the starter key to "LOCK" and connect the signal check harness.
2. Disconnect the connector of EGR solenoid valve 1.
3. Set the starter key to "ON" and measure the voltage between the +5V terminal and the GND terminal of the EGR lift sensor connector (at vehicle harness side).

Standard value : 5 ±0.5 V

NG

[2] Go to measurement of voltage between terminals.

OK

[3] Go to measurement of voltage between terminals.

2 Measurement of voltage between terminals

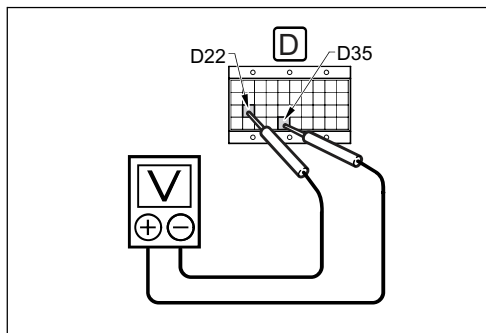

SAPH300021600068

1. Measure the voltage between terminal D22 and terminal D35 of the signal check harness.

Standard value : 5 ±0.5 V

NG

Engine ECU failure, ECU connector failure

OK

3 Measurement of voltage between terminals

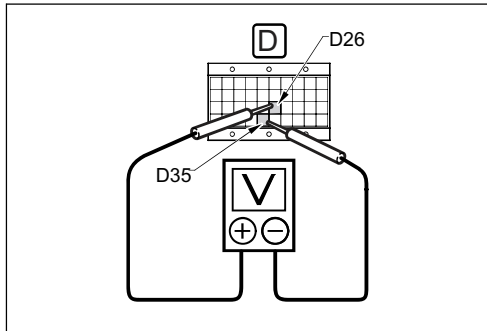

1. Set the starter key to "LOCK" and connect the connector of EGR solenoid valve 1.
2. Set the starter key to "ON" and measure the voltage between terminal D26 and terminal D35 of the signal check harness.

Standard value : 1.3 to 4.0 V

NG

[4] Go to measurement of voltage between terminals.

OK

Engine ECU failure, ECU connector failure

4 Measurement of voltage between sensor terminals

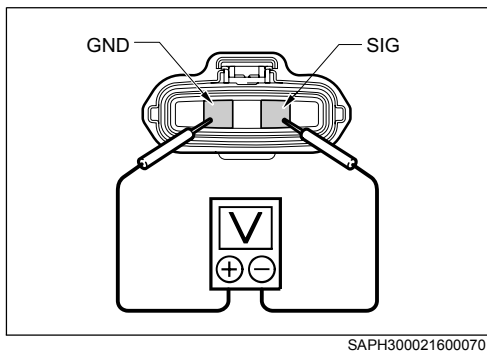

1. Leave the connector of the EGR lift sensor connected.
2. Measure the voltage between the SIG terminal and the GND terminal of the EGR lift sensor connector (at vehicle harness side).

Standard value : 1.3 to 4.0 V

NG

Failure of EGR lift sensor

OK

Harness failure

EGR lift sensor 2 malfunction (DTC code P0407, P0408/diagnosis monitor code 87)

JP30002160601034

DTC	P0407	EGR lift sensor 2 circuit low input
DTC	P0408	EGR lift sensor 2 circuit high input

1 Measurement of voltage between sensor terminals

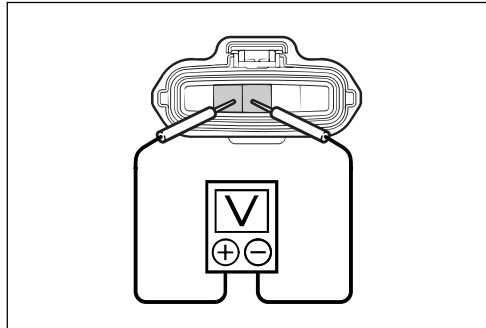

SAPH300021600071

1. Set the starter key to "LOCK" and remove the signal check harness.
2. Disconnect the connector of EGR valve 1.
3. Set the starter key to "ON" and measure the voltage between the +5V terminal and the GND terminal of the EGR lift sensor connector (at vehicle harness side).

Standard value : 5 ±0.5 V

NG

[2] Go to measurement of voltage between terminals.

OK

[3] Go to measurement of voltage between terminals.

2 Measurement of voltage between terminals

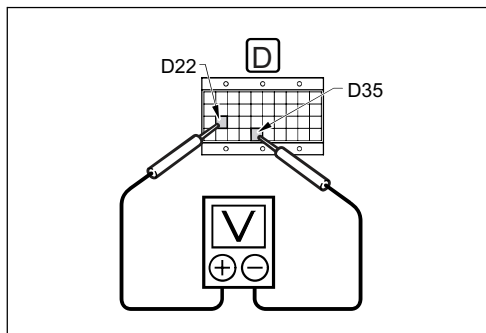

SAPH300021600072

1. Measure the voltage between terminal D22 and terminal D35 of the signal check harness.

Standard value : 5 ±0.5 V

NG

Engine ECU failure, ECU connector failure

OK

3 Measurement of voltage between terminals

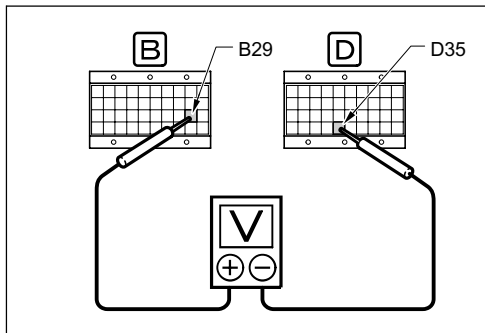

1. Set the starter key to "LOCK" and connect the connector of EGR solenoid valve 1.
2. Set the starter key to "ON" and measure the voltage between terminal B29 and terminal D35 of the signal check harness.

Standard value : 1.3 to 4.0 V

NG

[4] Go to measurement of voltage between terminals.

OK

Engine ECU failure, ECU connector failure

4 Measurement of voltage between sensor terminals

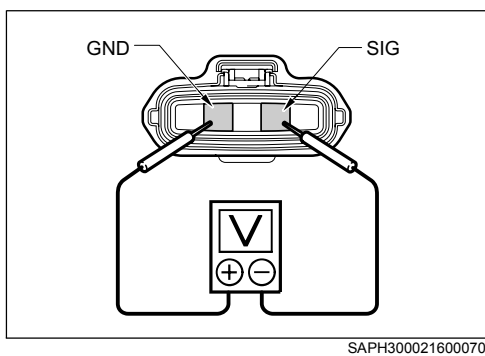

1. Leave the connector of the EGR lift sensor connected.
2. Measure the voltage between the SIG terminal and the GND terminal of the EGR lift sensor connector (at vehicle harness side).

Standard value : 1.3 to 4.0 V

NG

Failure of EGR lift sensor

OK

Harness failure

Preheat circuit malfunction (DTC code P0540/diagnosis monitor code 25)

JP30002160601035

1 Measurement of resistance between terminals

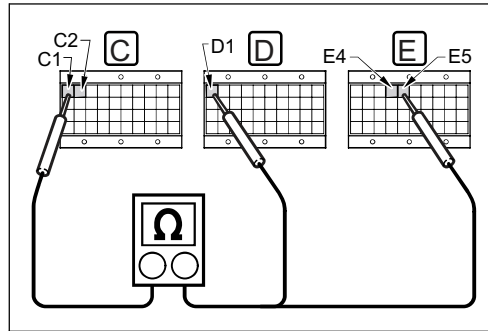

1. Set the starter key to "LOCK" and connect the signal check harness.
2. Disconnect the ECU side connector of the signal check harness and measure the resistance between terminals C1, C2 and terminals D1, E4, E5.

Standard value : $25 \pm 2.5 \Omega$

NG

[2] Go to measurement of resistance between terminals.

OK

Engine ECU failure, ECU connector failure

2 Measurement of relay resistance

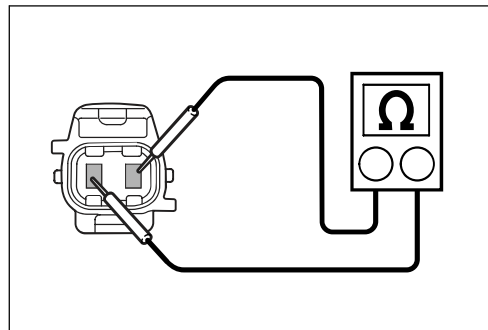

1. Remove the heater relay and measure the resistance between terminals.

Standard value : $24.8 \pm 0.5 \Omega$

NG

Heater relay failure

OK

Harness failure, connector failure

Injector correction data conformity error (DTC code P1601/diagnosis monitor code 2)

JP30002160601036

1 Inspection of QR code



SAPH300021600004

1. Read the QR code data with the failure diagnosis tool (HINO field support system) using PC.

Standard value : The code shall conform to the QR code registered in the service server.

NG

Write the QR code again.

OK

Replace engine ECU.

ECU internal error (DTC code P0605, P0606, P0607/diagnosis monitor code 3)

JP30002160601037

DTC	P0605	Flash ROM error
DTC	P0606	CPU malfunction (Hard detection)
DTC	P0607	Monitoring IC malfunction in CPU

1 Check of diagnosis code

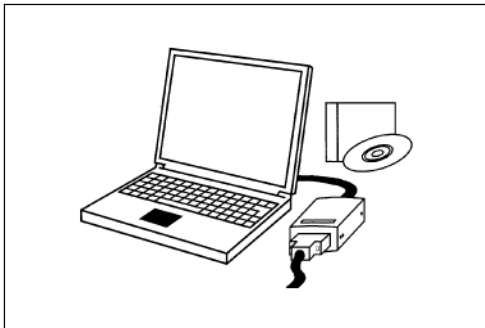

SAPH300021600004

1. Set the starter key to "LOCK" and set it to "ON" again.
2. After deleting the past failure, check if the same code (DTC code P0605, P0606, P0607/diagnosis monitor code 3) is output again.

Standard : Normal

NG

Engine ECU failure

OK

Since it may be a temporary malfunction due to radio interference, it is acceptable when the system recovers normal operation.

ECU charge circuit malfunction (DTC code P0200, P0611/diagnosis monitor code 59)

JP30002160601038

DTC	P0200	ECU charge circuit high input
DTC	P0611	ECU charge circuit malfunction

1 Check of ECU

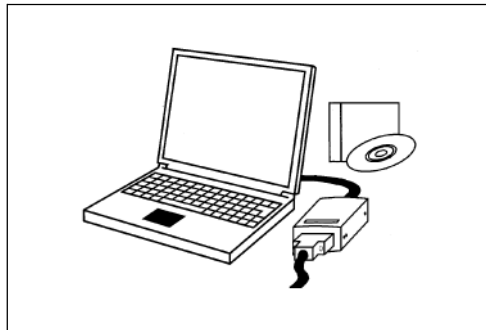

SAPH300021600004

1. Set the starter key to "LOCK" and set it to "ON" again.
2. After deleting the past failure, check if the same code (DTC code P0611, P0200/diagnosis monitor code 59) is output again.

Standard : Normal

NG

Engine ECU failure

OK

Since it may be a temporary malfunction due to radio interference, it is acceptable when the system recovers normal operation.

Main relay malfunction (DTC code P0686/diagnosis monitor code 5)

JP30002160601039

1 Measurement of voltage between terminals

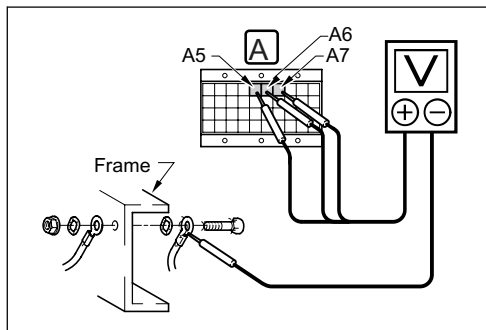

SAPH300021600076

1. Set the starter key to "LOCK" and connect the signal check harness.
2. Disconnect the ECU side connector of the signal check harness and set the starter key to "ON". Measure the voltage between terminals A5, A6, A7 and the chassis GND.

Standard value : 0 V

NG

[2] Go to measurement of resistance between terminals.

OK

Engine ECU failure, engine ECU connector failure

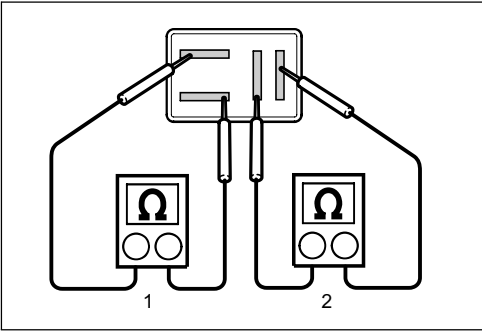
2 Measurement of resistance between relay terminals

1. Set the starter key to "LOCK", remove the main relay and measure the resistance between terminals.

Standard value

: 282 to 369 Ω between terminals in Fig. "1"

: $\infty\Omega$ between terminals in Fig. "2"

NG

Main relay failure

OK

Harness failure

Idle volume malfunction (DTC code P1142, P1143/diagnosis monitor code 44)

JP30002160601040

1 Measurement of voltage between switch terminals

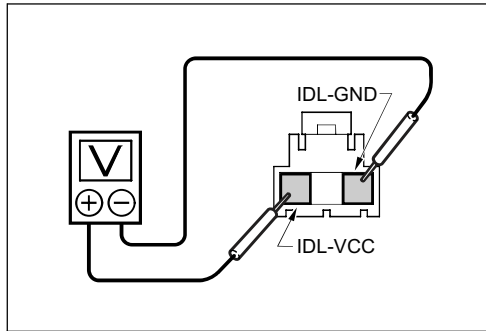

1. Set the starter key to "LOCK" and connect the signal check harness.
2. Disconnect the connector of the idle set button.
3. Set the starter key to "ON" and measure the voltage between the IDL-VCC terminal and the IDL-GND terminal of the idle set button connector (at vehicle harness side).

Standard value : 5 ± 0.5 V

NG

[2] Go to measurement of voltage between terminals.

OK

[3] Go to measurement of voltage between terminals.

2 Measurement of voltage between terminals

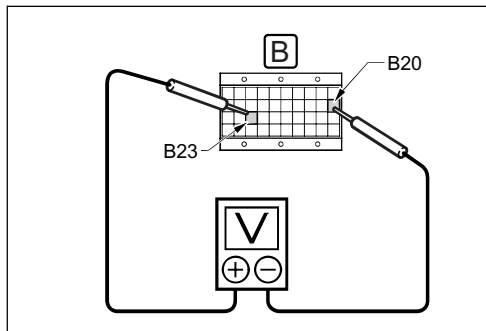

1. Measure voltage between terminal B23 and terminal B20 of the signal check harness.

Standard value : 5 ± 0.5 V

NG

Engine ECU failure, ECU connector failure

OK

Harness disconnection

3 Measurement of voltage between terminals

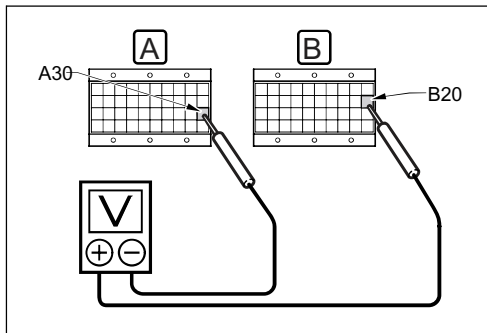

SAPH300021600080

1. Set the starter key to "LOCK" and connect the connector of the idle set button.
2. Set the starter key to "ON" and measure the voltage between terminal A30 and terminal B20 of the signal check harness.

Standard value

- : 0 V (status turned full to the left)
- : Approx. 0.7 V (status turned full to the left)
- : Approx. 4.3 V (status turned full to the right)

NG

[4] Go to measurement of voltage between switch terminals.

OK

Engine ECU failure, ECU connector failure

4 Measurement of voltage between switch terminals

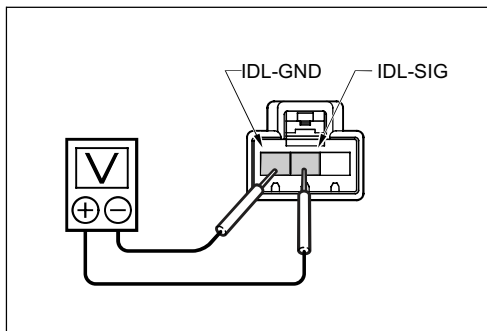

SAPH300021600081

1. Leave the connector of the idle set button connected.
2. Measure the voltage between the IDL-SIG terminal and the IDL-GND terminal of the idle set button (at part side).

Standard value

- : 0 V (status turned full to the left)
- : Approx. 0.7 V (status turned full to the left)
- : Approx. 4.3 V (status turned full to the right)

NG

Idle set button failure

OK

Disconnection or short-circuit of harness

Idle switch malfunction (DTC code P0510/diagnosis monitor code 42)

JP30002160601041

1 Measurement of voltage between terminals

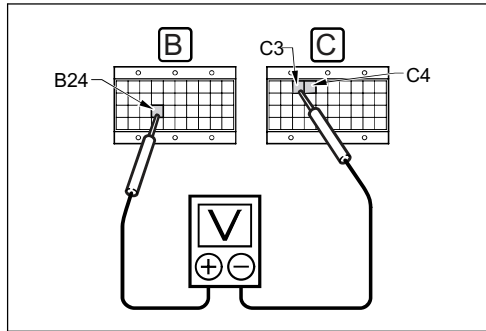

SAPH300021600082

1. Set the starter key to "LOCK" and connect the signal check harness.
2. Set the starter key to "ON" and measure the voltage between terminal B24 and terminals C3/C4 of the signal check harness.

Standard value

- : 19 V or more (status without depressing the accelerator pedal)
- : 0 V (full throttle status)

NG

[2] Go to measurement of resistance between terminals.

OK

Engine ECU failure

2 Measurement of resistance between switch terminals

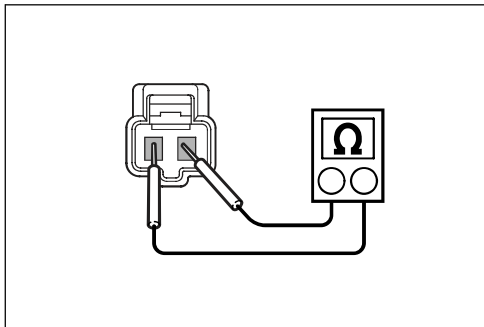

SAPH300021600084

1. Set the starter key to "LOCK", disconnect the idle switch connector and measure the resistance between terminals at the switch side.

Standard value

- : 2 or less (status without depressing the accelerator pedal)
- : $\infty\Omega$ (full throttle status)

NG

Idle switch failure

OK

Harness failure

Starter signal malfunction (DTC code P0617/diagnosis monitor code 45)

JP30002160601042

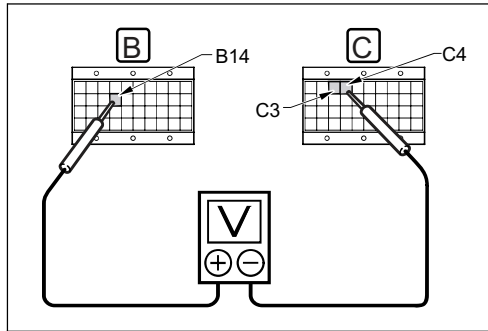
1 Measurement of voltage between terminals

1. Set the starter key to "LOCK" and connect the signal check harness.
2. Disconnect the ECU side connector of the signal check harness and set the starter key to "ON".
3. Measure voltage between terminal B14 and terminals C3/C4.

CAUTION • Since the engine may start, shift the gear to neutral to prevent movement of the vehicle.

Standard value

- : 0 V (when starter key is at "LOCK")
- : 24 V (when starter key is at "START")

NG

Harness failure

OK

Engine ECU failure, ECU connector failure